



中国认可  
国际互认  
检测  
TESTING  
CNAS L2291



Access to the World

# TEST REPORT

**Product Name : Solar Storage Inverter**  
**Model Number : AFP4850S100-H, HSI 5000AP**

Prepared for : SRNE Solar Co., Ltd  
Address : 4-5F, Building13A, Taihua Wutong Industrial Park, Gushu  
Development Zone, Hangcheng Street, Baoan, Shenzhen,  
China PR

Prepared by : EMTEK (SHENZHEN) CO., LTD.  
Address : Building 69, Majialong Industry Zone, Nanshan District,  
Shenzhen, Guangdong, China

Tel: (0755) 26954280  
Fax: (0755) 26954282

Report Number : ENS2505090261E00201R  
Date(s) of Tests : May 16, 2025 to June 23, 2025  
Date of issue : June 23, 2025



## TABLE OF CONTENT

Test Report Description	Page
<b>1. SUMMARY OF TEST RESULTS .....</b>	<b>7</b>
<b>2. GENERAL INFORMATION .....</b>	<b>9</b>
2.1. Description of Device (EUT) .....	9
2.2. Independent Operation Modes.....	9
2.3. Test Manner .....	10
2.4. Description of Test Facility .....	10
2.5. Description of Support Device.....	11
2.6. Measurement Uncertainty .....	11
<b>3. MEASURING DEVICE AND TEST EQUIPMENT .....</b>	<b>12</b>
3.1. For Power Line Conducted Emission Measurement .....	12
3.2. For Radiated Emission Measurement.....	12
3.3. For Harmonic Current / Flicker Measurement .....	12
3.4. For Electrostatic Discharge Immunity Test .....	12
3.5. For RF Strength Susceptibility Test.....	13
3.6. For Electrical Fast Transient / Burst Immunity Test .....	13
3.7. For Surge Immunity Test .....	13
3.8. For Injected Current Susceptibility Test.....	14
3.9. For Magnetic Field Immunity Test.....	14
3.10. For Voltage Dips and Interruptions Test .....	14
<b>4. POWER LINE CONDUCTED EMISSION MEASUREMENT .....</b>	<b>15</b>
4.1. Block Diagram of Test Setup.....	15
4.2. Measuring Standard .....	15
4.3. Power Line Conducted Emission Limits .....	15
4.4. Test Procedure .....	16
4.5. Measuring Results .....	16
<b>5. RADIATED EMISSION MEASUREMENT .....</b>	<b>21</b>
5.1. Block Diagram of Test Setup.....	21
5.2. Measuring Standard .....	21
5.3. Radiated Emission Limits .....	21
5.4. Test Procedure .....	22
5.5. Measuring Results .....	22
<b>6. HARMONIC CURRENT EMISSION MEASUREMENT .....</b>	<b>25</b>
6.1. Block Diagram of Test Setup.....	25
6.2. Standard Limits.....	25
6.3. Measuring Results .....	25
<b>7. VOLTAGE FLUCTUATION AND FLICKER MEASUREMENT .....</b>	<b>29</b>
7.1. Block Diagram of Test Setup.....	29
7.2. Standard Limits.....	29
7.3. Test Procedure .....	29
7.4. Test Results.....	29
<b>8. IMMUNITY PERFORMANCE CRITERIA DESCRIPTION .....</b>	<b>31</b>
<b>9. ELECTROSTATIC DISCHARGE IMMUNITY TEST .....</b>	<b>32</b>
9.1. Block Diagram of Test Setup.....	32

9.2. Test Standard .....	32
9.3. Severity Levels and Performance Criterion .....	32
9.4. Test Procedure .....	33
9.5. Test Results.....	33
<b>10. RF FIELD STRENGTH SUSCEPTIBILITY TEST .....</b>	<b>35</b>
10.1. Block Diagram of Test Setup .....	35
10.2. Test Standard .....	35
10.3. Severity Levels and Performance Criterion .....	35
10.4. Test Procedure .....	36
10.5. Test Results.....	36
<b>11. ELECTRICAL FAST TRANSIENT/BURST IMMUNITY TEST .....</b>	<b>38</b>
11.1. Block Diagram of Test Setup .....	38
11.2. Test Standard .....	38
11.3. Severity Levels and Performance Criterion .....	39
11.4. Test Procedure .....	39
11.5. Test Results.....	39
<b>12. SURGE IMMUNITY TEST .....</b>	<b>41</b>
12.1. Block Diagram of Test Setup .....	41
12.2. Test Standar .....	41
12.3. Severity Levels and Performance Criterion .....	41
12.4. Test Procedure .....	41
12.5. Test Results.....	41
<b>13. INJECTED CURRENTS SUSCEPTIBILITY TEST .....</b>	<b>43</b>
13.1. Block Diagram of Test Setup .....	43
13.2. Test Standard .....	43
13.3. Severity Levels and Performance Criterion .....	43
13.4. Test Procedure .....	44
13.5. Test Results.....	44
<b>14. MAGNETIC FIELD SUSCEPTIBILITY TEST .....</b>	<b>46</b>
14.1. Block Diagram of Test Setup .....	46
14.2. Test Standard .....	46
14.3. Severity Levels and Performance Criterion .....	46
14.4. Test Procedure .....	47
14.5. Test Results.....	47
<b>15. VOLTAGE DIPS AND INTERRUPTIONS TEST .....</b>	<b>49</b>
15.1. Block Diagram of Test Setup .....	49
15.2. Test Standard .....	49
15.3. Severity Levels and Performance Criterion .....	49
15.4. Test Procedure .....	49
15.5. Test Results.....	49
<b>16. PHOTOGRAPHS .....</b>	<b>51</b>
16.1. Photos of Conducted Emission Measurement .....	51
16.2. Photos of Radiation Emission Measurement .....	52
16.3. Photo of Harmonic / Flicker Measurement .....	53
16.4. Photo of Electrostatic Discharge Test .....	53
16.5. Photo of RF Field Strength Susceptibility Test .....	54
16.6. Photo of Electrical Fast Transient / Burst Test .....	54
16.7. Photo of Surge Test .....	55
16.8. Photo of Injected Currents Susceptibility Test.....	56
16.9. Photo of Magnetic Field Immunity Test .....	57
16.10.Photo of Voltage Dips and Interruption Immunity Test .....	58

APPENDIX (Photos of EUT) (3 Pages)



## TEST REPORT DESCRIPTION

Applicant : SRNE Solar Co., Ltd  
Manufacturer : SRNE Solar Co., Ltd  
Trade Mark :  **SRNE**  
Product Name : Solar Storage Inverter  
Model Number : AFP4850S100-H, HSI 5000AP  
Rating : AC Input: 170-280Vac, 50/60Hz  
AC Output: 220/230Vac  
PV Input: 60-500Vdc  
Battery Input: 40-60Vdc

### Measurement Procedure Used:

EN IEC 61000-6-3:2021  
EN 61000-3-12:2011  
EN IEC 61000-3-11:2019  
EN IEC 61000-6-1:2019  
(IEC 61000-4-2:2008, IEC 61000-4-3:2006+A1:2007+A2:2010, IEC 61000-4-4:2012,  
IEC 61000-4-5:2014, IEC 61000-4-6:2013, IEC 61000-4-8:2009, IEC 61000-4-34:2005+A1:2009)

The device described above is tested by EMTEK (SHENZHEN) CO., LTD. to determine the maximum emission levels emanating from the device and the severe levels of the device can endure and its performance criterion. The measurement results are contained in this test report and EMTEK (SHENZHEN) CO., LTD. is assumed full of responsibility for the accuracy and completeness of these measurements. Also, this report shows that the EUT (Equipment Under Test) is technically compliant with the EN IEC 61000-6-3, EN 61000-3-12, EN IEC 61000-3-11 and EN IEC 61000-6-1 requirements.

This report applies to above tested sample only and shall not be reproduced in part without written approval of EMTEK (SHENZHEN) CO., LTD.

Date of Test : May 16, 2025 to June 23, 2025

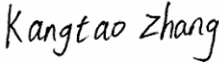
Prepared by :   
Kangtao Zhang/Editor

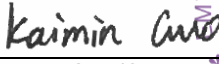
Reviewer :   
Kaimin Guo/Supervisor

Approved & Authorized Signer :   
Lisa Wang/Manager

## Modified Information

Version	Report No.	Revision Date	Summary
/	ENS2505090261E00201R	/	Original Report



## 1. SUMMARY OF TEST RESULTS

EMISSION				
Description of Test Item		Standard	Limits	Results
Conducted Emissions at Mains Terminals	AC Mains port	EN IEC 61000-6-3:2021	Table 4	Pass
	DC Power port <input type="checkbox"/> V-AN <input checked="" type="checkbox"/> Δ-AN		Table 5	Pass
Discontinuous disturbance at mains terminals		Cited from CISPR 14-1	CISPR 14-1	N/A
Conducted Emissions at wired network ports		Cited from CISPR 32	Table 6	N/A
Radiated emissions at frequencies up to 1 GHz		EN IEC 61000-6-3:2021	Table 3	Pass
Radiated emissions at frequencies above 1 GHz		EN IEC 61000-6-3:2021	Table 3	N/A
Harmonic Current Emissions		EN 61000-3-12:2011	Table 2	Pass
Voltage Fluctuation and Flicker		EN IEC 61000-3-11: 2019	--	Pass
DC power port terminal disturbance for class b GCPC-Proportion relation approach		Cited from CISPR 11	Table C.1	N/A
DC power port terminal disturbance for class b GCPC-Current-to-voltage Conversion approach		Cited from CISPR 32	Table C.2	N/A

IMMUNITY (EN IEC 61000-6-1:2019)			
Description of Test Item	Basic Standard	Performance Criteria	Results
Electrostatic Discharge (ESD)	IEC 61000-4-2:2008	B	Pass
Radio-Frequency, Continuous Radiated Disturbance	IEC 61000-4-3:2006+A1:2007+A2:2010	A	Pass
EFT/B Immunity	Signal/control ports	IEC 61000-4-4:2012	N/A
	DC power ports		Pass
	AC power ports		Pass
Surge Immunity	Signal/control ports	IEC 61000-4-5:2014	N/A
	DC power ports		Pass
	AC power ports		Pass
Conducted RF Immunity	Signal/control ports	IEC 61000-4-6:2013	N/A
	DC power ports		Pass
	AC power ports		Pass
Power Frequency Magnetic Field	IEC 61000-4-8:2009	A	Pass
Voltage dips and interruptions	IEC 61000-4-34:2005+A1:2009	B,C	Pass
Note: N/A means not applicable.			

## 2. GENERAL INFORMATION

### 2.1. Description of Device (EUT)

Product Name	: Solar Storage Inverter
Model Number	: AFP4850S100-H, HSI 5000AP (Note: These models are identical in circuitry and electrical, mechanical and physical construction; the only difference is the model. We prepare AFP4850S100-H for test)
Sample ID	: ENS2505090261E002/1-1
Test Voltage	: AC 230V/50Hz&DC 450V, AC 230V/50Hz, DC 48V
Applicant	: SRNE Solar Co., Ltd
Address	: 4-5F, Building13A, Taihua Wutong Industrial Park, Gushu Development Zone, Hangcheng Street, Baoan, Shenzhen, China PR
Manufacturer	: SRNE Solar Co., Ltd
Address	: 4-5F, Building13A, Taihua Wutong Industrial Park, Gushu Development Zone, Hangcheng Street, Baoan, Shenzhen, China PR
Factory	: SRNE SOLAR CO., LTD Dongguan Branch
Address	: Room 301, Building 5th, Fuxing Rd No.36, Chang'an Town, Dongguan City, Guangdong Province, China PR
Date of Received	: May 16, 2025
Date of Test	: May 16, 2025 to June 23, 2025

### 2.2. Independent Operation Modes

- A. On
  - 1. PV In & AC Grid
  - 2. AC Charging
  - 3. Discharging & AC Back UP

### 2.3. Test Manner

Test Items	Test Voltage	Operation Modes	Worst case
Conducted Emissions at Mains Terminals (AC Mains port)	AC 230V/50Hz&DC 450V AC 230V/50Hz	Mode A.1 Mode A.2	Mode A.1
Conducted Emissions at Mains Terminals (DC Power port)	AC 230V/50Hz&DC 450V	Mode A.1	Mode A.1
Radiated emissions at frequencies up to 1 GHz	AC 230V/50Hz&DC 450V AC 230V/50Hz DC 48V	Mode A	Mode A.3
Harmonic Current Emissions	AC 230V/50Hz&DC 450V	Mode A.1	\
Voltage Fluctuation and Flicker	AC 230V/50Hz&DC 450V	Mode A.1	\
Electrostatic Discharge	AC 230V/50Hz&DC 450V AC 230V/50Hz DC 48V	Mode A	\
Continuous RF electromagnetic field disturbances	AC 230V/50Hz&DC 450V AC 230V/50Hz DC 48V	Mode A	\
Electrical fast transients/burst	AC 230V/50Hz&DC 450V AC 230V/50Hz	Mode A.1 Mode A.2	\
Surges	AC 230V/50Hz&DC 450V AC 230V/50Hz	Mode A.1 Mode A.2	\
Continuous induced RF disturbances	AC 230V/50Hz&DC 450V AC 230V/50Hz	Mode A.1 Mode A.2	\
Power frequency magnetic field	AC 230V/50Hz&DC 450V AC 230V/50Hz DC 48V	Mode A	\
Voltage dips and interruptions	AC 230V/50Hz	Mode A.2	\

### 2.4. Description of Test Facility

Site Description  
EMC Lab.

: **Accredited by CNAS**

The Certificate Registration Number is L2291.

The Laboratory has been assessed and proved to be in compliance with CNAS-CL01 (identical to ISO/IEC 17025:2017)

**Accredited by FCC**

Designation Number: CN1204

Test Firm Registration Number: 882943

**Accredited by A2LA**

The Certificate Number is 4321.01.

**Accredited by Industry Canada**

The Conformity Assessment Body Identifier is CN0008

Name of Firm

: EMTEK (SHENZHEN) CO., LTD.

Site Location

: Building 69, Majialong Industry Zone, Nanshan District, Shenzhen, Guangdong, China

## 2.5. Description of Support Device

N/A

## 2.6. Measurement Uncertainty

Test Item	Uncertainty
Conducted Emission Uncertainty (Conduction 2#)	: 3.16dB (9k~150kHz Conduction) 2.90dB (150k-30MHz Conduction)
Radiated Emission Uncertainty (3m 3# Chamber)	: 4.28dB (30M~1GHz Polarize: H) 4.86dB (30M~1GHz Polarize: V)
Uncertainty for Flicker test	: 0.514%
Uncertainty for Harmonic test	: 4.04%
Uncertainty for C/S Test	: 0.94dB(Using CDN Test) 2.37dB(Using EM Clamp Test)
Uncertainty for R/S Test	: 1.53dB(80MHz-3000MHz)
Uncertainty for test site temperature and humidity	: 0.6°C 4%

### 3. MEASURING DEVICE AND TEST EQUIPMENT

#### 3.1. For Power Line Conducted Emission Measurement

Used	Equipment	Manufacturer	Model No.	Serial No.	Last Cal.	Cal. Interval
<input checked="" type="checkbox"/>	EMI Test Receiver	Rohde & Schwarz	ESCI	101045	May 09, 2025	1 Year
<input checked="" type="checkbox"/>	PULSE LIMITER	Schwarzbeck	VTSD 9561 F-B	00955	May 09, 2025	1 Year
<input checked="" type="checkbox"/>	AMN	Schwarzbeck	NNLK 8129	8129203	May 09, 2025	1 Year
<input checked="" type="checkbox"/>	DC LISN	Schwarzbeck	PVDC 8301	00075	May 09, 2025	1 Year

#### 3.2. For Radiated Emission Measurement

Used	Equipment	Manufacturer	Model No.	Serial No.	Last Cal.	Cal. Interval
<input checked="" type="checkbox"/>	EMI Test Receiver	Rohde & Schwarz	ESU 26	100154	May 09, 2025	1 Year
<input checked="" type="checkbox"/>	Pre-Amplifier	Lunar EM	LNA30M3G-25	J10100000070	May 09, 2025	1 Year
<input checked="" type="checkbox"/>	Bilog Antenna	Schwarzbeck	VULB9163	661	May 18, 2025	2 Year

#### 3.3. For Harmonic Current / Flicker Measurement

Used	Equipment	Manufacturer	Model No.	Serial No.	Last Cal.	Cal. Interval
<input checked="" type="checkbox"/>	45KVA AC Power source	Teseq	NSG 1007-45/45KVA	1305A02873	May 10, 2025	1 Year
<input checked="" type="checkbox"/>	Signal conditioning Unit	Teseq	CCN 1000-3	1305A02873	May 10, 2025	1 Year
<input checked="" type="checkbox"/>	Impedance network	Teseq	INA2197/37A	1305A02873	May 10, 2025	1 Year
<input checked="" type="checkbox"/>	Impedance network	Teseq	INA 2196/75A	1305A02874	May 10, 2025	1 Year
<input type="checkbox"/>	Proflin 2100 AC Switching Unit	Teseq	NSG 2200-3	A22714	May 10, 2025	1 Year

#### 3.4. For Electrostatic Discharge Immunity Test

Used	Equipment	Manufacturer	Model No.	Serial No.	Last Cal.	Cal. Interval
<input checked="" type="checkbox"/>	ESD Tester	EMTEST	Dito	P2220263883	Oct. 21, 2024	1 Year

### 3.5. For RF Strength Susceptibility Test

Used	Equipment	Manufacturer	Model No.	Serial No.	Last Cal.	Cal. Interval
<input checked="" type="checkbox"/>	Power Amplifier	MILMEGA	AS0102-55	1018770	May 09, 2025	1 Year
<input checked="" type="checkbox"/>	RF Power Meter. Dual Channel	BOONTON	4232A	10539	May 09, 2025	1 Year
<input checked="" type="checkbox"/>	Log.-Per. Antenna	SCHWARZBECK	STLP 9129-7/16	3050	N/A	N/A
<input checked="" type="checkbox"/>	Signal Generator	Agilent	N5181A	MY501451 87	May 09, 2025	1 Year
<input checked="" type="checkbox"/>	50ohm Diode Power Sensor	BOONTON	51011EMC	36164	May 09, 2025	1 Year
<input checked="" type="checkbox"/>	Field Strength Meter	DARE	RSS1006A	10I00037S NO22	May 13, 2025	1 Year
<input checked="" type="checkbox"/>	Multi-function interface system	DARE	CTR1009B	12I00250S NO72	N/A	N/A
<input checked="" type="checkbox"/>	Automatic switch group	DARE	RSW1004A	N/A	N/A	N/A
<input checked="" type="checkbox"/>	Power Amplifier	MILMEGA	AS1860-50	1059346	May 09, 2025	1 Year
<input checked="" type="checkbox"/>	Power Amplifier	Vectawave	VBA 1000-600C	133627	Oct. 18, 2024	1 Year
<input checked="" type="checkbox"/>	Directional Coupler	BONN	BDC 0810-50/1500	2229689	Oct. 18, 2024	1 Year

### 3.6. For Electrical Fast Transient / Burst Immunity Test

Used	Equipment	Manufacturer	Model No.	Serial No.	Last Cal.	Cal. Interval
<input checked="" type="checkbox"/>	Burst Tester	Partner	IMU-MGS	109938-1635	Oct. 18, 2024	1 Year
<input checked="" type="checkbox"/>	Coupling Clamp	HAEFELY	IP-4A	147147	May 09, 2025	1 Year
<input checked="" type="checkbox"/>	Three phase CDN	Teseq	CDN 163	202	May 09, 2025	1 Year

### 3.7. For Surge Immunity Test

Used	Equipment	Manufacturer	Model No.	Serial No.	Last Cal.	Cal. Interval
<input checked="" type="checkbox"/>	Controller	HAEFELY	Psurge 8000	174031	May 10, 2025	1 Year
<input checked="" type="checkbox"/>	Impulse Module	HAEFELY	PIM 100	174124	May 10, 2025	1 Year
<input checked="" type="checkbox"/>	Coupling Decoupling	HAEFELY	PCD 130	172181	May 10, 2025	1 Year
<input type="checkbox"/>	Coupling Module	HAEFELY	PCD122	174354	May 10, 2025	1 Year
<input type="checkbox"/>	Impulse Module	HAEFELY	PIM 120	174435	May 10, 2025	1 Year
<input type="checkbox"/>	Coupling Module	HAEFELY	PCD 126A	174387	May 10, 2025	1 Year
<input type="checkbox"/>	Impulse Module	HAEFELY	PIM 110	174391	May 10, 2025	1 Year
<input type="checkbox"/>	Impulse Module	HAEFELY	PIM 150	178707	May 10, 2025	1 Year
<input type="checkbox"/>	Impulse Module	PMI	PCDN8	190422	May 10, 2025	1 Year

### 3.8. For Injected Current Susceptibility Test

Used	Equipment	Manufacturer	Model No.	Serial No.	Last Cal.	Cal. Interval
<input checked="" type="checkbox"/>	Continuous Wave Simulator	EMTEST	CWS500C	0900-12	May 11, 2025	1 Year
<input checked="" type="checkbox"/>	EM Injection Clamp	EMTEST	F-2031-23MM	368	May 09, 2025	1 Year
<input checked="" type="checkbox"/>	Attenuator	EMTEST	100W 6dB DC-3G	/	May 11, 2025	1 Year
<input checked="" type="checkbox"/>	Signal Generator	R&S	SMB100A	103041	May 09, 2025	1 Year
<input checked="" type="checkbox"/>	Three phase CDN	TESEQ	CDN M332S	32655	May 11, 2025	1 Year
<input checked="" type="checkbox"/>	Power meter	AGILENT	E4418B	MY45102886	May 11, 2025	1 Year
<input checked="" type="checkbox"/>	Directional coupler	SKET	DC_0110000M-100W	SK2018080301	May 11, 2025	1 Year

### 3.9. For Magnetic Field Immunity Test

Used	Equipment	Manufacturer	Model No.	Serial No.	Last Cal.	Cal. Interval
<input checked="" type="checkbox"/>	Magnetic Field Tester	HAEFELY	MAG100	250040.1	May 10, 2025	1 Year

### 3.10. For Voltage Dips and Interruptions Test

Used	Equipment	Manufacturer	Model No.	Serial No.	Last Cal.	Cal. Interval
<input checked="" type="checkbox"/>	45KVA AC Power source	Teseq	NSG 1007-45/45KVA	1305A02873	May 10, 2025	1 Year
<input type="checkbox"/>	Signal conditioning Unit	Teseq	CCN 1000-3	1305A02873	May 10, 2025	1 Year
<input type="checkbox"/>	Impedance network	Teseq	INA2197/37A	1305A02873	May 10, 2025	1 Year
<input type="checkbox"/>	Impedance network	Teseq	INA 2196/75A	1305A02874	May 10, 2025	1 Year
<input checked="" type="checkbox"/>	Proflin 2100 AC Switching Unit	Teseq	NSG 2200-3	A22714	May 10, 2025	1 Year

## 4. POWER LINE CONDUCTED EMISSION MEASUREMENT

### 4.1. Block Diagram of Test Setup

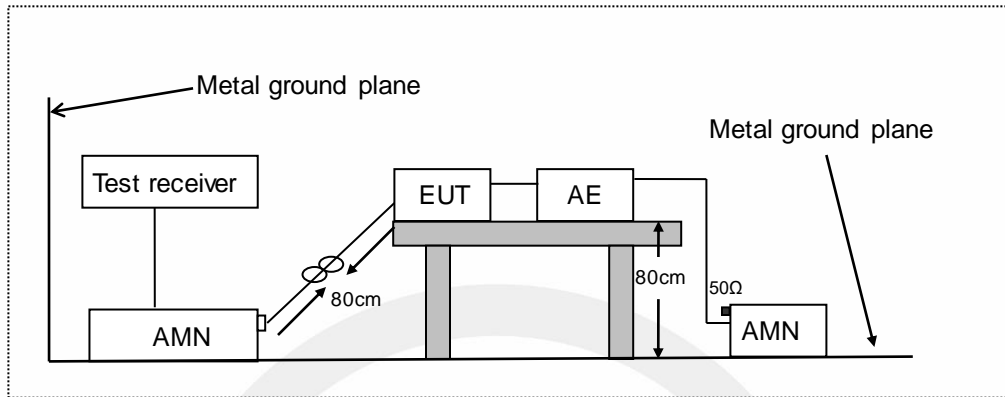

LISN: Artificial Mains Network  
 AE: Associated equipment  
 EUT: Equipment under test

### 4.2. Measuring Standard

EN IEC 61000-6-3:2021

### 4.3. Power Line Conducted Emission Limits

AC Mains port:

Frequency (MHz)	Limit (dB $\mu$ V)	
	Quasi-peak Level	Average Level
0.15 ~ 0.50	66.0 ~ 56.0 *	56.0 ~ 46.0 *
0.50 ~ 5.00	56.0	46.0
5.00 ~ 30.00	60.0	50.0

NOTE1-The lower limit shall apply at the transition frequencies.

NOTE2-The limit decreases linearly with the logarithm of the frequency in the range 0.15MHz to 0.50MHz.

DC Power port ( $\Delta$ -AN):

Frequency (MHz)	Limit (dB $\mu$ V)	
	Quasi-peak Level	Average Level
0.15 ~ 0.50	84.0 ~ 74.0 *	74.0 ~ 64.0 *
0.50 ~ 30.00	74.0	64.0

NOTE1-The lower limit shall apply at the transition frequencies.

NOTE2-The limit decreases linearly with the logarithm of the frequency in the range 0.15MHz to 0.50MHz.

#### 4.4. Test Procedure

The EUT is put on the plane 0.8 m high above the ground by insulating support and connected to the AC mains through Line Impedance Stability Network (L.I.S.N). This provided a 50ohm coupling impedance for the tested equipments. Both sides of AC line are investigated to find out the maximum conducted emission according to the EN IEC 61000-6-3 regulations during conducted emission measurement.

The bandwidth of the field strength meter (R&S Test Receiver) is set at 9kHz in 150kHz~30MHz and 200Hz in 9kHz~150kHz.

The frequency range from 150kHz to 30MHz is investigated.

#### 4.5. Measuring Results

**PASS.**

All the modes were tested and the data of the worst modes are attached the following pages.

Temperature : 26°C  
Humidity : 52%  
Atmospheric Pressure : 101kpa  
Test Engineer : Jinren Tan  
Test Date : 2025-06-09

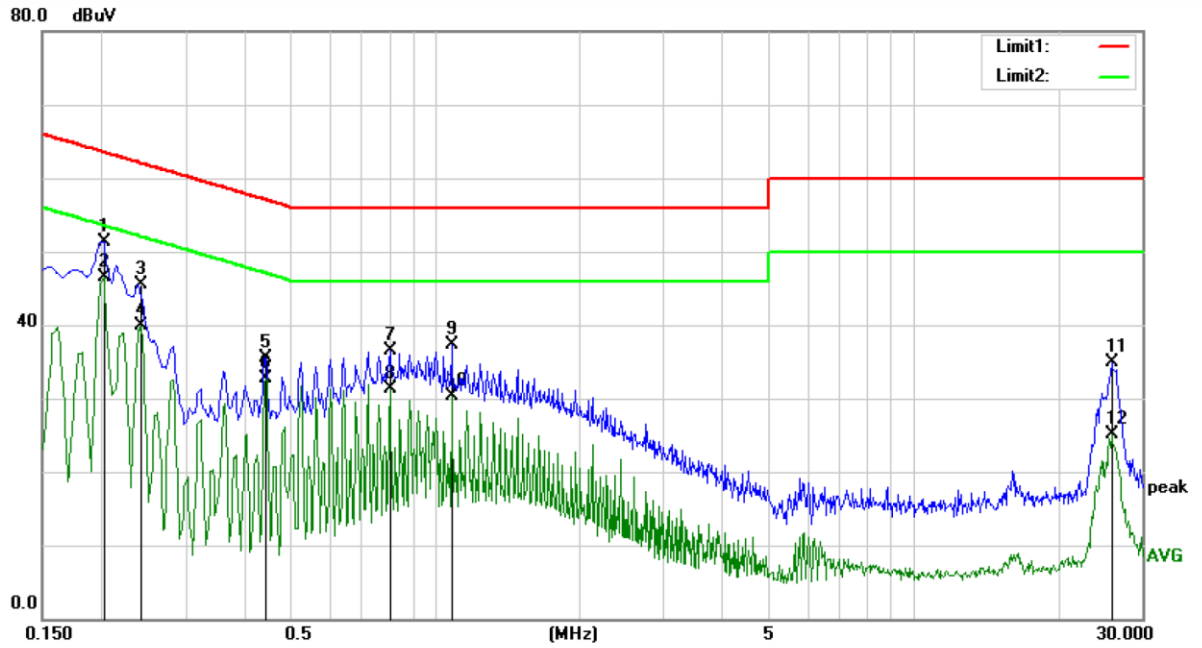

Site Conduction 2#

Phase: **L1**

Temperature: 26

Limit: (CE)EN61000-6-3\_QP

Power: AC 230V/50Hz&DC 450V

Humidity: 52 %

Mode: PV IN & AC Grid

Note:

No.	Mk.	Freq. MHz	Reading Level dBuV	Correct Factor dB	Measure- ment dBuV	Limit dBuV	Over dB	Detector	Comment
1		0.2020	40.75	10.50	51.25	63.53	-12.28	QP	
2	*	0.2020	35.93	10.50	46.43	53.53	-7.10	AVG	
3		0.2420	34.95	10.52	45.47	62.03	-16.56	QP	
4		0.2420	29.29	10.52	39.81	52.03	-12.22	AVG	
5		0.4420	24.94	10.63	35.57	57.02	-21.45	QP	
6		0.4420	22.01	10.63	32.64	47.02	-14.38	AVG	
7		0.8020	26.07	10.47	36.54	56.00	-19.46	QP	
8		0.8020	20.83	10.47	31.30	46.00	-14.70	AVG	
9		1.0820	26.64	10.58	37.22	56.00	-18.78	QP	
10		1.0820	19.79	10.58	30.37	46.00	-15.63	AVG	
11		25.9620	23.84	11.11	34.95	60.00	-25.05	QP	
12		25.9620	13.94	11.11	25.05	50.00	-24.95	AVG	

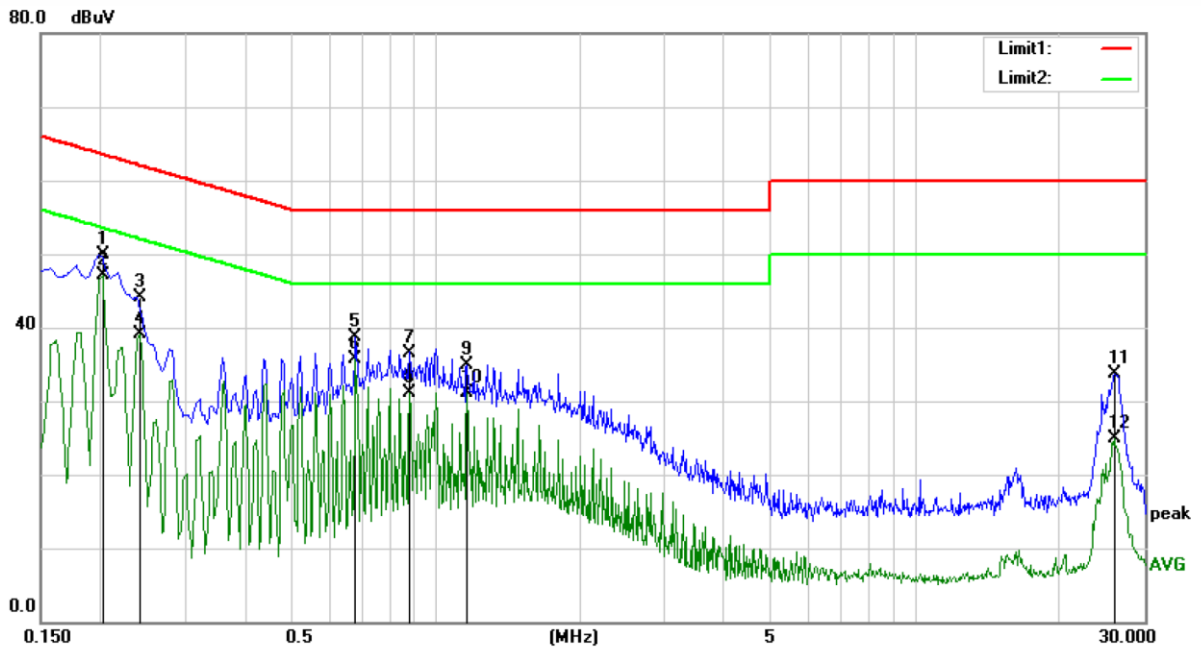

Site Conduction 2#

Phase: **N**

Temperature: 26

Limit: (CE)EN61000-6-3\_QP

Power: AC 230V/50Hz&DC 450V

Humidity: 52 %

Mode: PV IN & AC Grid

Note:

No.	Mk.	Freq. MHz	Reading Level dBuV	Correct Factor dB	Measure- ment dBuV	Limit dBuV	Over dB	Detector	Comment
1		0.2020	39.44	10.50	49.94	63.53	-13.59	QP	
2	*	0.2020	36.61	10.50	47.11	53.53	-6.42	AVG	
3		0.2420	33.67	10.52	44.19	62.03	-17.84	QP	
4		0.2420	28.61	10.52	39.13	52.03	-12.90	AVG	
5		0.6820	28.33	10.44	38.77	56.00	-17.23	QP	
6		0.6820	25.25	10.44	35.69	46.00	-10.31	AVG	
7		0.8820	26.09	10.51	36.60	56.00	-19.40	QP	
8		0.8820	20.61	10.51	31.12	46.00	-14.88	AVG	
9		1.1620	24.27	10.58	34.85	56.00	-21.15	QP	
10		1.1620	20.49	10.58	31.07	46.00	-14.93	AVG	
11		25.9620	22.65	11.11	33.76	60.00	-26.24	QP	
12		25.9620	13.80	11.11	24.91	50.00	-25.09	AVG	

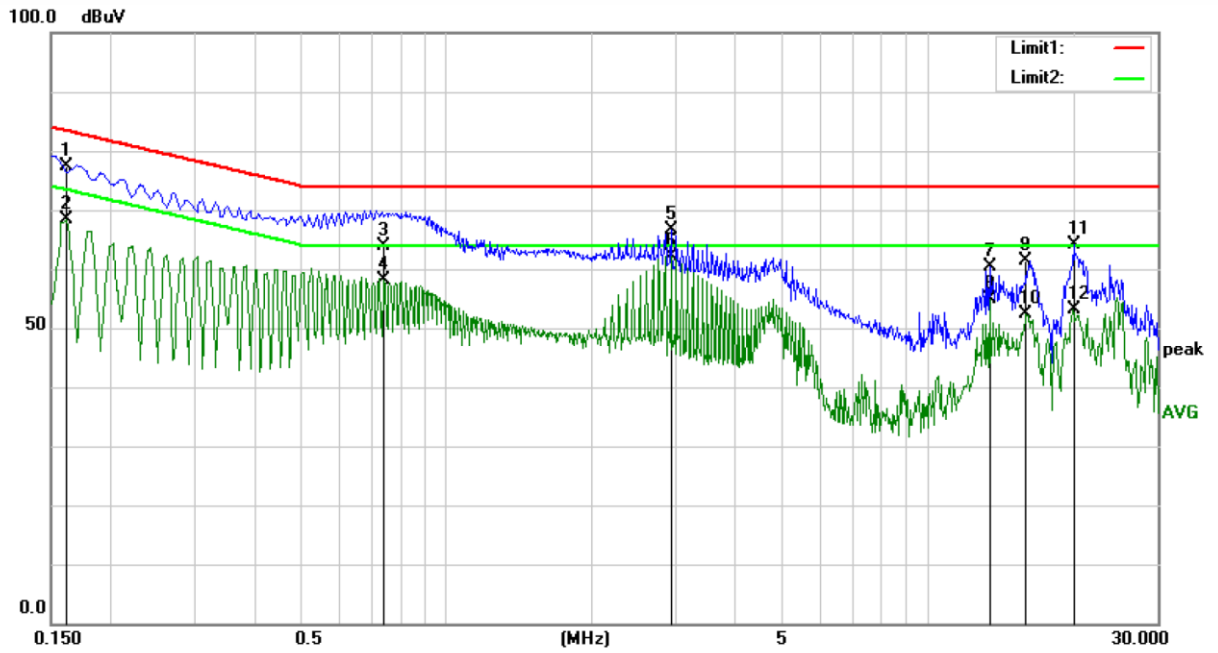

Site Conduction 2#

Phase: **CM**

Temperature: 26

Limit: (CE)EN61000-6-3\_DC PORT\_QP

Power: AC 230V/50Hz&DC 450V

Humidity: 52 %

Mode: PV IN & AC Grid

Note:

No.	Mk.	Freq. MHz	Reading Level dBuV	Correct Factor dB	Measure- ment dBuV	Limit dBuV	Over dB	Detector	Comment
1		0.1620	57.51	19.77	77.28	83.36	-6.08	QP	
2		0.1620	48.49	19.77	68.26	73.36	-5.10	AVG	
3		0.7420	44.24	19.56	63.80	74.00	-10.20	QP	
4		0.7420	38.67	19.56	58.23	64.00	-5.77	AVG	
5		2.9220	46.94	19.76	66.70	74.00	-7.30	QP	
6	*	2.9220	42.44	19.76	62.20	64.00	-1.80	AVG	
7		13.4520	39.78	20.66	60.44	74.00	-13.56	QP	
8		13.4520	34.34	20.66	55.00	64.00	-9.00	AVG	
9		15.9820	40.31	21.10	61.41	74.00	-12.59	QP	
10		15.9820	31.24	21.10	52.34	64.00	-11.66	AVG	
11		20.1320	42.12	21.91	64.03	74.00	-9.97	QP	
12		20.1320	31.13	21.91	53.04	64.00	-10.96	AVG	

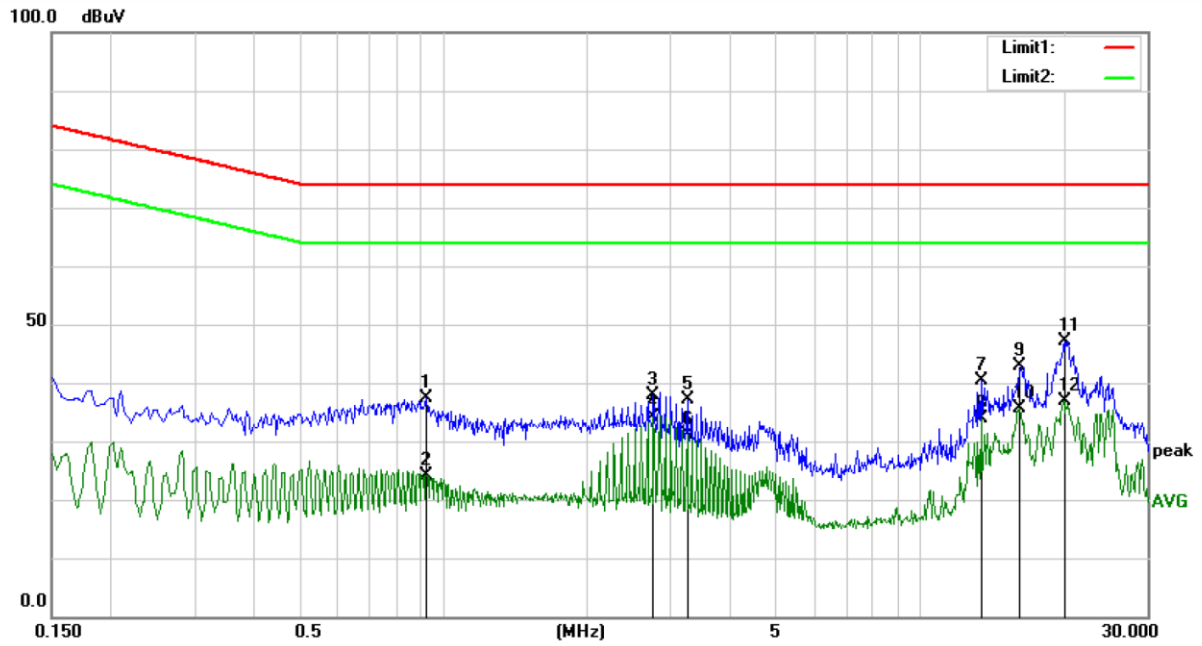

Site Conduction 2#

Phase: **DM**

Temperature: 26

Limit: (CE)EN61000-6-3\_DC PORT\_QP

Power: AC 230V/50Hz&DC 450V

Humidity: 52 %

Mode: PV IN & AC Grid

Note:

No.	Mk.	Freq. MHz	Reading Level dBuV	Correct Factor dB	Measure- ment dBuV	Limit dBuV	Over dB	Detector	Comment
1		0.9220	17.85	19.53	37.38	74.00	-36.62	QP	
2		0.9220	4.59	19.53	24.12	64.00	-39.88	AVG	
3		2.7620	18.10	19.75	37.85	74.00	-36.15	QP	
4		2.7620	14.28	19.75	34.03	64.00	-29.97	AVG	
5		3.2420	17.43	19.78	37.21	74.00	-36.79	QP	
6		3.2420	11.33	19.78	31.11	64.00	-32.89	AVG	
7		13.4520	19.76	20.66	40.42	74.00	-33.58	QP	
8		13.4520	13.14	20.66	33.80	64.00	-30.20	AVG	
9		16.1920	21.73	21.15	42.88	74.00	-31.12	QP	
10		16.1920	14.54	21.15	35.69	64.00	-28.31	AVG	
11	*	20.1320	25.23	21.91	47.14	74.00	-26.86	QP	
12		20.1320	15.07	21.91	36.98	64.00	-27.02	AVG	

## 5. RADIATED EMISSION MEASUREMENT

### 5.1. Block Diagram of Test Setup

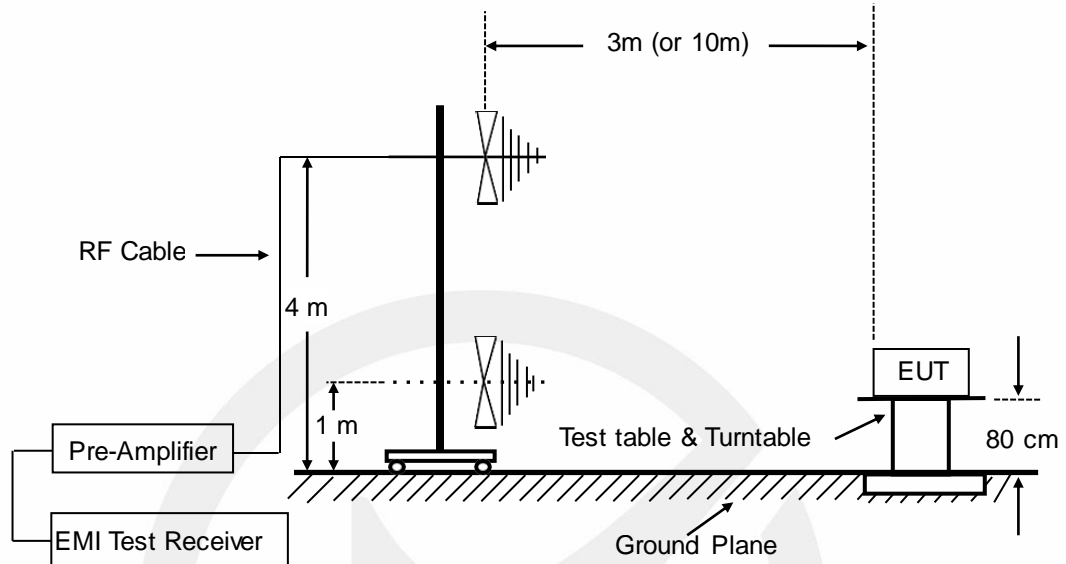

### 5.2. Measuring Standard

EN IEC 61000-6-3:2021

### 5.3. Radiated Emission Limits

FREQUENCY (MHz)	DISTANCE (Meters)	FIELD STRENGTHS LIMIT (dB $\mu$ V/m)
30 ~ 230	3	40
230 ~ 1000	3	47

- Note: (1) The smaller limit shall apply at the combination point between two frequency bands.  
(2) Distance refers to the distance in meters between the measuring instrument antenna and the closed point of any part of the EUT.

#### 5.4. Test Procedure

The EUT is placed on a turntable which is 0.8 meter high above the ground. The turntable can rotate 360 degrees to determine the position of the maximum emission level. The EUT is set 3 meters away from the receiving antenna that is mounted on a antenna tower. The antenna can be moved up and down from 1 to 4 meters to find out the maximum emission level. Bilog antenna (calibrated by Dipole Antenna) is used as a receiving antenna. Both horizontal and vertical polarization of the antenna is set on test.

The bandwidth of the Receiver (ESCI) is set at 120kHz.

#### 5.5. Measuring Results

**PASS.**

All the modes were tested and the data of the worst modes are attached the following pages.

Temperature : 23.5°C  
Humidity : 60%  
Atmospheric Pressure : 101kpa  
Test Engineer : Chengtao Yin  
Test Date : 2025-06-17

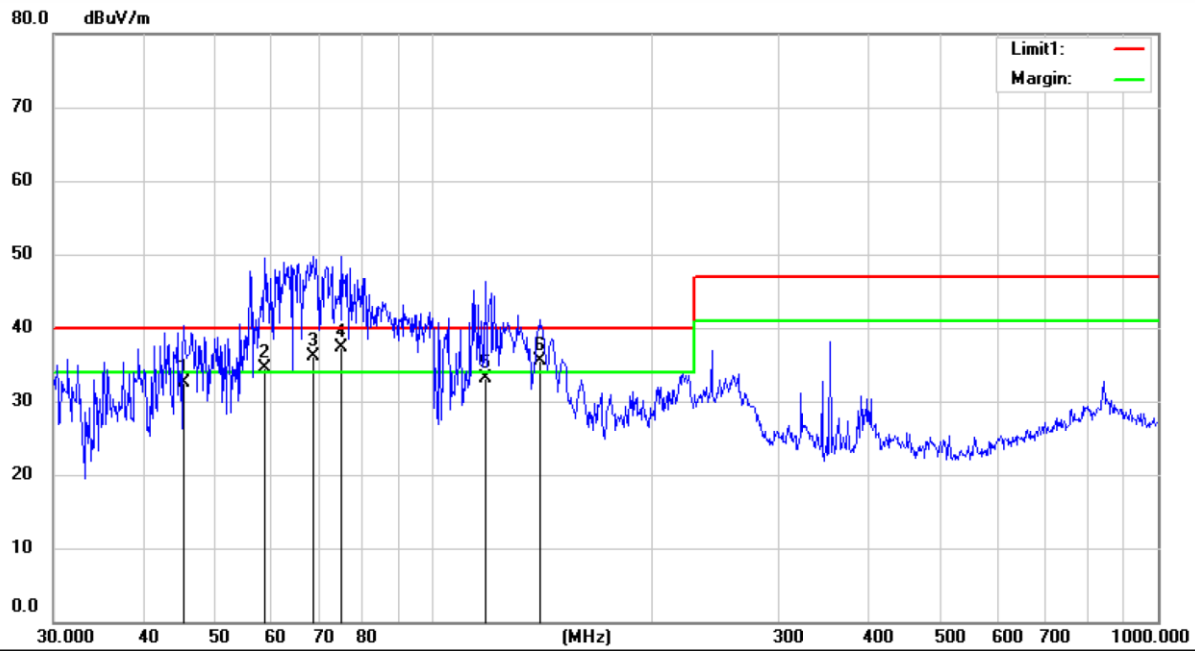

Site 3m Chamber #3 Polarization: **Horizontal** Temperature: 23.5 C  
 Limit: (RE)EN61000-6-3 Power: DC 48V Humidity: 60 %  
 Mode: Discharging&AC Back UP  
 Note:

No.	Mk.	Freq.	Reading Level	Correct Factor	Measurement	Limit	Over	Antenna Height	Table Degree	
		MHz	dBuV	dB	dBuV/m	dBuV/m	dB	cm	degree	Comment
1		45.3755	47.17	-14.57	32.60	40.00	-7.40	QP		
2	!	58.6126	49.16	-14.56	34.60	40.00	-5.40	QP		
3	!	68.3908	51.76	-15.66	36.10	40.00	-3.90	QP		
4	*	74.6570	54.23	-16.83	37.40	40.00	-2.60	QP		
5		118.1862	49.50	-16.40	33.10	40.00	-6.90	QP		
6	!	140.3421	53.11	-17.51	35.60	40.00	-4.40	QP		



## 6. HARMONIC CURRENT EMISSION MEASUREMENT

### 6.1. Block Diagram of Test Setup

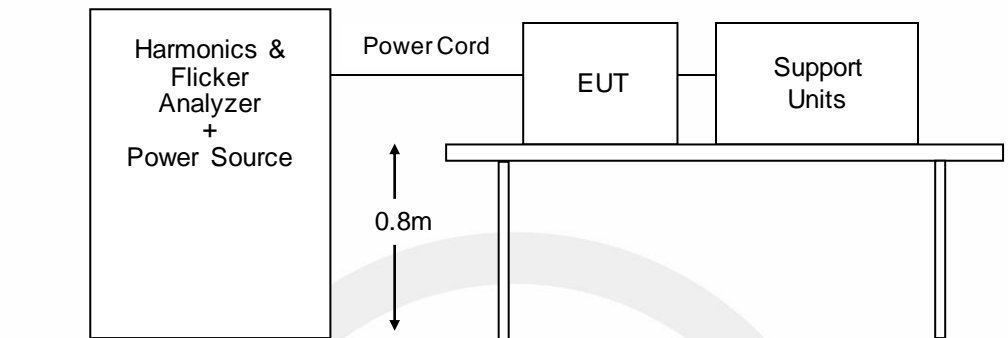

### 6.2. Standard Limits

EN 61000-3-12

Harmonic current emissions evaluate the potential for the EUT to cause distortion on the AC power lines. It is applicable to electrical and electronic equipment having an input current  $>16\text{ A}$  and  $\leq 75\text{ A}$  per phase, and intended to be connected to public low-voltage distribution systems

**Table 2 – Current emission limits for equipment other than balanced three-phase equipment**

Minimum $R_{sce}$	Admissible individual harmonic current $I_h/I_{ref}$ <sup>a</sup> %						Admissible harmonic parameters %	
	$I_3$	$I_5$	$I_7$	$I_9$	$I_{11}$	$I_{13}$	$THC/I_{ref}$	$PWHC/I_{ref}$
33	21,6	10,7	7,2	3,8	3,1	2	23	23
66	24	13	8	5	4	3	26	26
120	27	15	10	6	5	4	30	30
250	35	20	13	9	8	6	40	40
$\geq 350$	41	24	15	12	10	8	47	47

The relative values of even harmonics up to order 12 shall not exceed  $16/h\%$ . Even harmonics above order 12 are taken into account in  $THC$  and  $PWHC$  in the same way as odd order harmonics.

Linear interpolation between successive  $R_{sce}$  values is permitted.

<sup>a</sup>  $I_{ref}$  = reference current;  $I_h$  = harmonic current component.

### 6.3. Measuring Results

**PASS.**

Please see the attached pages.







## 7. VOLTAGE FLUCTUATION AND FLICKER MEASUREMENT

### 7.1. Block Diagram of Test Setup

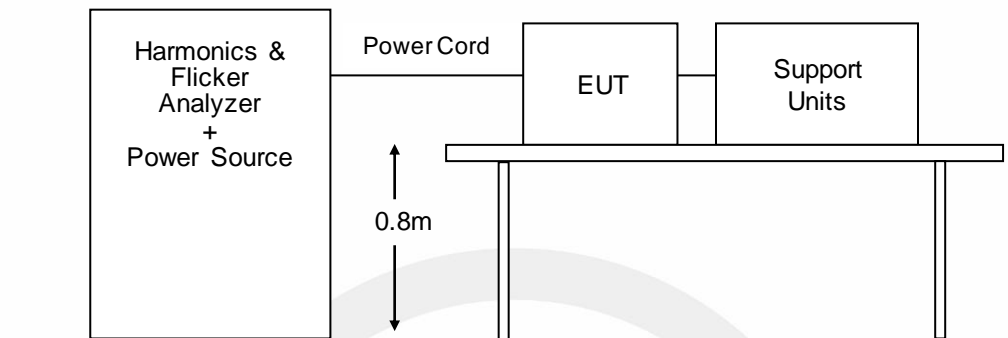

### 7.2. Standard Limits

#### EN IEC 61000-3-11 Limits

The limits shall be applicable to voltage fluctuations and flicker at the supply terminals of the equipment under test, measured or calculated according to clause 4 under test conditions described in clause 6. Tests made to prove the compliance with the limits are considered to be type tests.

The following limits apply:

- the value of the short-term flicker indicator,  $P_{st}$  shall not be greater than 1,0;
- the value of the long-term flicker indicator,  $P_{lt}$  shall not be greater than 0,65;
- the value of  $d(t)$  during a voltage change shall not exceed 3,3 % for more than 500 ms;
- the relative steady-state voltage change,  $d_c$ , shall not exceed 3,3 %;
- the maximum relative voltage change  $d_{max}$ , shall not exceed:

### 7.3. Test Procedure

The total impedance of the test circuit, excluding the appliance under test, but including the internal impedance of the supply source, shall be equal to the reference impedance. The stability and tolerance of the reference impedance shall be adequate to ensure that the overall accuracy of 8% is achieved during the whole assessment procedure.

### 7.4. Test Results

**PASS.**

Please see the attached page.

### Flicker Test Summary Per EN/IEC61000-3-11 (Run time)

EUT: Solar Storage Inverter  
 Test category: All parameters  
 Test date: 2025/5/25 Start time: 15:57:08  
 Test duration (min): 10 End time: 16:07:35  
 Comment: PV IN&AC Grid Data file name: CTSMXH\_F-000051.cts\_data  
 Customer: SRNE Solar Co., Ltd  
 Z-test = (0.400 + j 0.250 Ohm)

Test Result: Pass  
 Status: Test Completed

#### Pstj and limit line

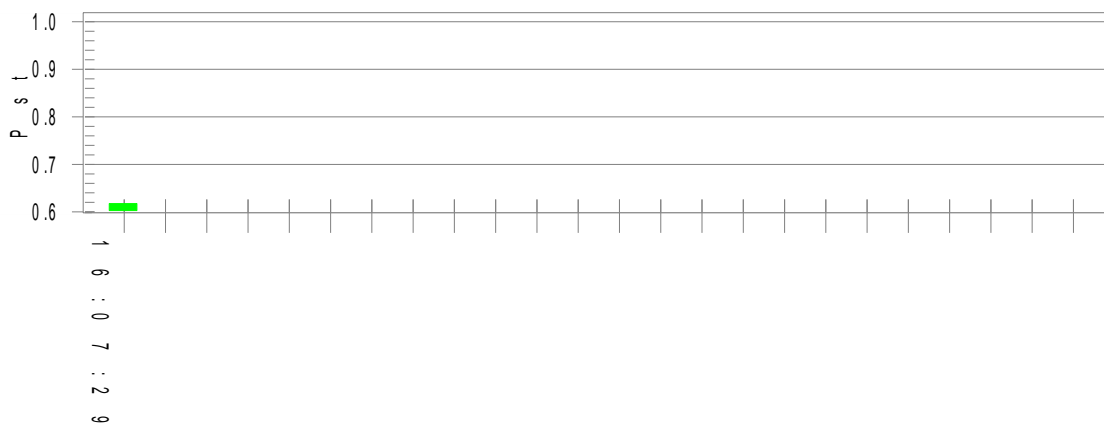

#### Parameter values recorded during the test:

Vrms at the end of test (Volt):	227.12			
T-max (mS):	0.0	Test limit (mS):	500.0	Pass
Highest dc (%):	0.00	Test limit (%):	3.30	Pass
Highest dmax (%):	1.11	Test limit (%):	4.00	Pass
Highest Pst (10 min. period):	0.617	Test limit:	1.000	Pass

Calculated dmax(%): 0.711  
 Calculated dc(%): 0.000  
 Calculated Pst : 0.618  
 Calculated Pit : 0.270

#### The maximum permissible system impedance Zsys:

Z = 0.824 Ohm + j 0.515 Ohm (0.824 Ohm + 1640 μH)

## 8. IMMUNITY PERFORMANCE CRITERIA DESCRIPTION

### Performance Level

The test results shall be classified in terms of the loss of function or degradation of performance of the equipment under test, relative to a performance level by its manufacturer or the requestor of the test, or the agreed between the manufacturer and the purchaser of the product.

Definition related to the performance level:

1. Based on the used product standard
2. Based on the declaration of the manufacturer, requestor or purchaser

#### Criterion A:

The apparatus shall continue to operate as intended during and after the test. No degradation of performance or loss of function is allowed below a performance level specified by the manufacturer, when the apparatus is used as intended. The performance level may be replaced by a permissible loss of performance. If the minimum performance level or the permissible performance loss is not specified by the manufacturer, either of these may be derived from the product description and documentation and what the user may reasonably expect from the apparatus if used as intended.

#### Criterion B:

The apparatus shall continue to operate as intended after the test. No degradation of performance or loss of function is allowed below a performance level specified by the manufacturer, when the apparatus is used as intended. The performance level may be replaced by a permissible loss of performance. During the test, degradation of performance is however allowed. No change of actual operating state or stored data is allowed. If the minimum performance level or the permissible performance loss is not specified by the manufacturer, either of these may be derived from the product description and documentation and what the user may reasonably expect from the apparatus if used as intended.

#### Criterion C:

Temporary loss of function is allowed, provided the function is self-recoverable or can be restored by the operation of the controls.

## 9. ELECTROSTATIC DISCHARGE IMMUNITY TEST

### 9.1. Block Diagram of Test Setup

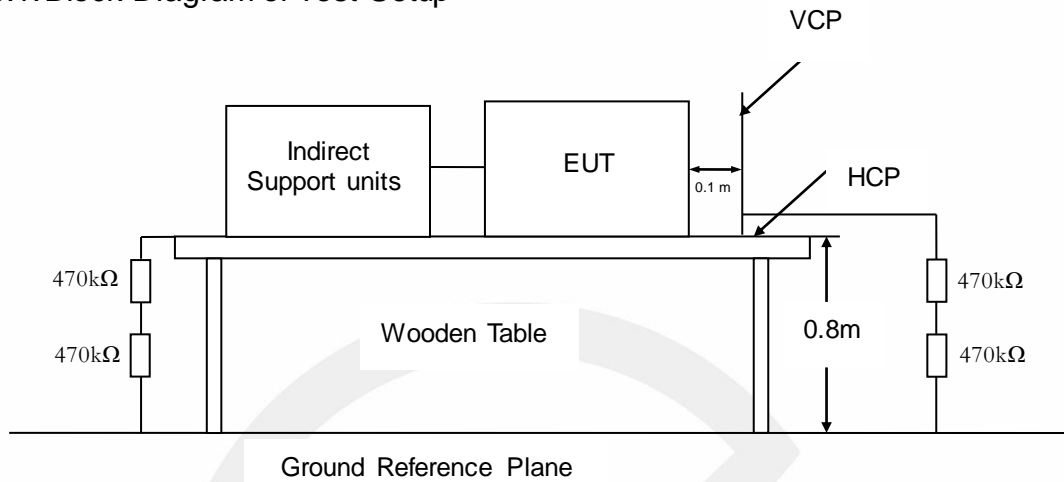

### 9.2. Test Standard

EN IEC 61000-6-1:2019

(IEC 61000-4-2:2008 Severity Level: 3 / Air Discharge:  $\pm 8\text{kV}$ )

Level: 2 / Contact Discharge:  $\pm 4\text{kV}$ )

### 9.3. Severity Levels and Performance Criterion

#### 9.3.1. Severity level

Level	Test Voltage Contact Discharge (kV)	Test Voltage Air Discharge (kV)
1	$\pm 2$	$\pm 2$
2	$\pm 4$	$\pm 4$
3	$\pm 6$	$\pm 8$
4	$\pm 8$	$\pm 15$
X	Special	Special

#### 9.3.2. Performance criterion: B

## 9.4. Test Procedure

### 9.4.1. Air Discharge:

This test is done on a non-conductive surface. The round discharge tip of the discharge electrode shall be approached as fast as possible to touch the EUT. After each discharge, the discharge electrode shall be removed from the EUT. The generator is then re-triggered for a new single discharge and repeated 10 times for each pre-selected test point. This procedure shall be repeated until all the air discharge completed.

### 9.4.2. Contact Discharge:

All procedure shall be the same as Section 9.4.1. except that the tip of the discharge electrode shall touch the EUT before the discharge switch is operated.

### 9.4.3. Indirect discharge for horizontal coupling plane

At least 10 single discharges (in the most sensitive polarity) shall be applied at the front edge of each HCP opposite the center point of each unit (if applicable) of the EUT and 0.1m from the front of the EUT. The long axis of the discharge electrode shall be in the plane of the HCP and perpendicular to its front edge during the discharge.

### 9.4.4. Indirect discharge for vertical coupling plane

At least 10 singles discharge (in the most sensitive polarity) shall be applied to the center of one vertical edge of the coupling plane. The coupling plane, of dimensions 0.5m×0.5m, is placed parallel to, and positioned at a distance of 0.1m from the EUT. Discharges shall be applied to the coupling plane, with this plane in sufficient different positions that the four faces of the EUT are completely illuminated.

## 9.5. Test Results

**PASS.**

Please refer to the following page.

## Electrostatic Discharge Test Result

EMTEK (SHENZHEN) CO., LTD.

Applicant : SRNE Solar Co., Ltd		
EUT : Solar Storage Inverter	Test Date : 2025-05-25	
M/N : AFP4850S100-H	Temperature : 22.9°C	
Power Supply : AC 230V/50Hz&DC 450V, AC 230V/50Hz, DC 48V	Humidity : 51%	
Air discharge : ± 8.0kV	Atmospheric Pressure : 101kpa	
Contact discharge : ± 4.0kV	Criterion : B	
Test mode : PV In&AC Grid, AC Charging, Discharging&AC Back Up		
<b>Location</b>	<b>Kind</b> A-Air Discharge C-Contact Discharge	<b>Result</b>
Metal/ Screw	C	A
Slot/ Button/ Screen/ USB/ LED	A	A
HCP	C	A
VCP of front	C	A
VCP of rear	C	A
VCP of left	C	A
VCP of right	C	A
Note:		

## 10. RF FIELD STRENGTH SUSCEPTIBILITY TEST

### 10.1. Block Diagram of Test Setup

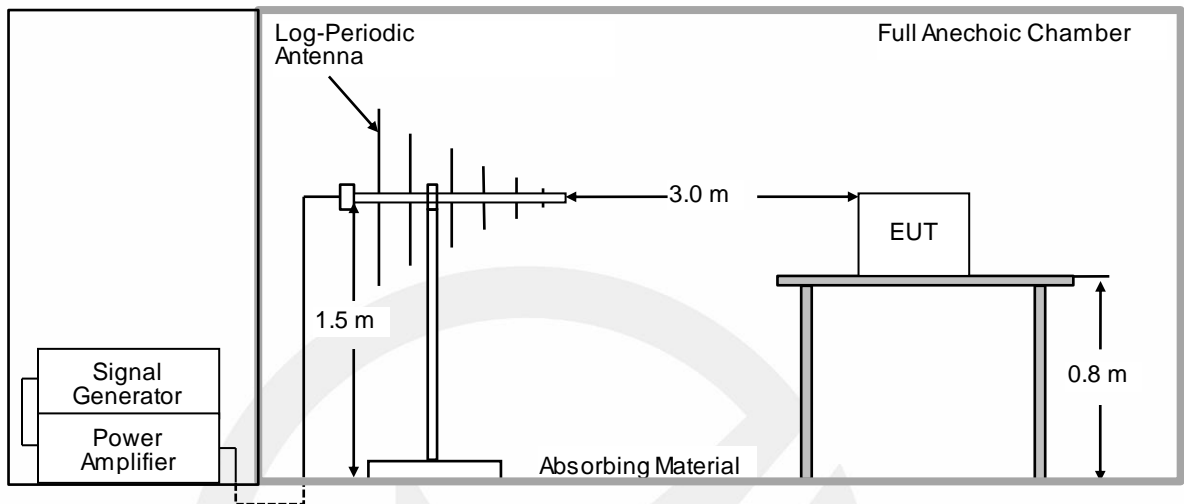

### 10.2. Test Standard

EN IEC 61000-6-1:2019  
(IEC 61000-4-3:2006+A1:2007+A2:2010, Severity Level 2: 3V/m)

### 10.3. Severity Levels and Performance Criterion

#### 10.3.1. Severity Levels

Level	Field Strength V/m
1.	1
2.	3
3.	10
X	Special

#### 10.3.2. Performance Criterion: A

### 10.4. Test Procedure

The EUT is placed on a table that is 0.8 meter high above the ground. The EUT is set 3 meters away from the transmitting antenna that is mounted on an antenna tower. Both horizontal and vertical polarization of the antenna is set on test. Each of the four sides of the EUT must be faced this transmitting antenna and measured individually.

In order to judge the EUT performance, a CCD camera is used to monitor it.

All the scanning conditions are as following:

Condition of Test	Remark
1. Fielded Strength	3V/m (Severity Level 2)
2. Radiated Signal	Modulated
3. Scanning Frequency	80-6000MHz
4. Sweep time of radiated	0.0015 Decade/s
5. Dwell Time	1 Sec.

### 10.5. Test Results

**PASS.**

Please refer to the following pages.

## RF Field Strength Susceptibility Test Results

EMTEK (SHENZHEN) CO., LTD.

Applicant : SRNE Solar Co., Ltd EUT : Solar Storage Inverter M/N : AFP4850S100-H Field Strength : 3 V/m Power Supply : AC 230V/50Hz&DC 450V, AC 230V/50Hz, DC 48V Test Mode : PV In&AC Grid, AC Charging, Discharging&AC Back Up Atmospheric Pressure : 101kpa	Test Date : 2025-05-25 Temperature : 23.2°C Humidity : 52% Criterion : A Frequency Range : 80 MHz to 1000 MHz 1400 MHz to 6000 MHz																									
Modulation: <input type="checkbox"/> None <input type="checkbox"/> Pulse <input checked="" type="checkbox"/> AM 1kHz 80%																										
Frequency Rang 1: 80~ 1000MHz Frequency Rang 2: 1400~ 6000 MHz																										
Steps 1%																										
	<table border="1" style="width: 100%; border-collapse: collapse;"> <thead> <tr> <th></th> <th style="width: 25%;">Horizontal</th> <th style="width: 25%;">Vertical</th> <th style="width: 25%;">Horizontal</th> <th style="width: 25%;">Vertical</th> </tr> </thead> <tbody> <tr> <td style="text-align: center;">Front</td> <td style="text-align: center;">A</td> <td style="text-align: center;">A</td> <td style="text-align: center;">A</td> <td style="text-align: center;">A</td> </tr> <tr> <td style="text-align: center;">Right</td> <td style="text-align: center;">A</td> <td style="text-align: center;">A</td> <td style="text-align: center;">A</td> <td style="text-align: center;">A</td> </tr> <tr> <td style="text-align: center;">Rear</td> <td style="text-align: center;">A</td> <td style="text-align: center;">A</td> <td style="text-align: center;">A</td> <td style="text-align: center;">A</td> </tr> <tr> <td style="text-align: center;">Left</td> <td style="text-align: center;">A</td> <td style="text-align: center;">A</td> <td style="text-align: center;">A</td> <td style="text-align: center;">A</td> </tr> </tbody> </table>		Horizontal	Vertical	Horizontal	Vertical	Front	A	A	A	A	Right	A	A	A	A	Rear	A	A	A	A	Left	A	A	A	A
	Horizontal	Vertical	Horizontal	Vertical																						
Front	A	A	A	A																						
Right	A	A	A	A																						
Rear	A	A	A	A																						
Left	A	A	A	A																						
Note:																										

## 11. ELECTRICAL FAST TRANSIENT/BURST IMMUNITY TEST

### 11.1. Block Diagram of Test Setup

AC Lines:

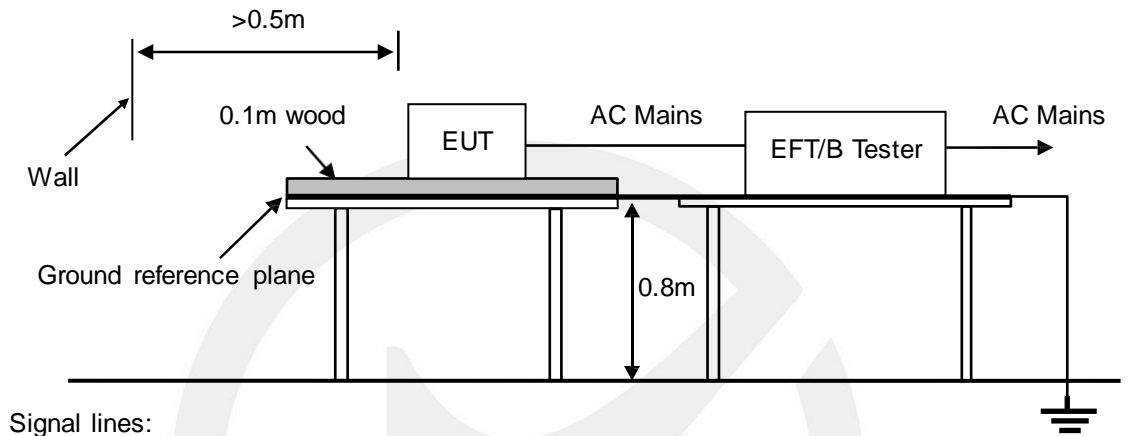

Signal lines:

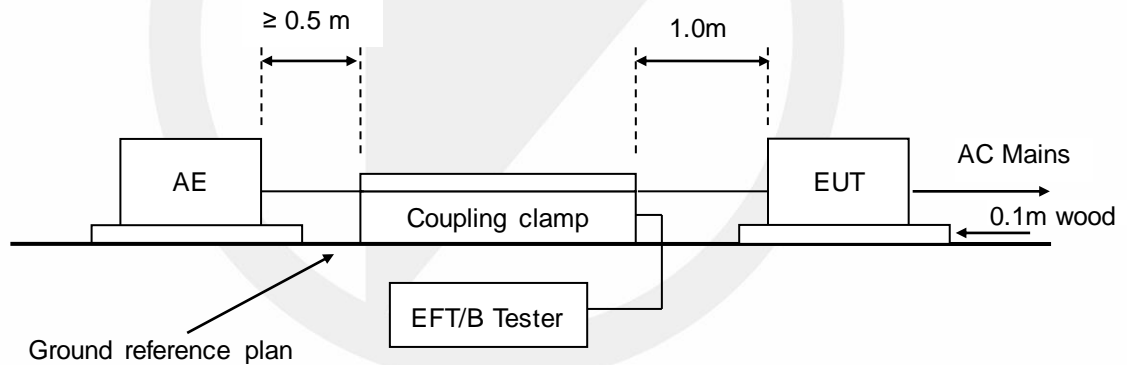

### 11.2. Test Standard

EN IEC 61000-6-1:2019

(IEC 61000-4-4:2012, Severity Level For AC Line: 1kV, Severity Level For DC Line/Signal: 0.5kV)

## 11.3. Severity Levels and Performance Criterion

### 11.3.1. Severity level

Open Circuit Output Test Voltage $\pm 10\%$		
Level	On Power Supply Lines	On I/O (Input/Output) Signal data and control lines
1	0.5 kV	0.25 kV
2	1 kV	0.5 kV
3	2 kV	1 kV
4	4 kV	2 kV
X	Special	Special

### 11.3.2. Performance criterion: B

## 11.4. Test Procedure

The EUT is put on the table that is 0.8meter high above the ground. This reference ground plane shall project beyond the EUT by at least 0.1m on all sides and the minimum distance between EUT and all other conductive structure, except the ground plane beneath the EUT, shall be more than 0.5m.

## 11.5. Test Results

**PASS.**

Please refer to the following page.

## Electrical Fast Transient/Burst Test Results

EMTEK (SHENZHEN) CO., LTD.

Applicant : <u>SRNE Solar Co., Ltd</u>			
EUT : <u>Solar Storage Inverter</u>		Test Date : <u>2025-05-25</u>	
M/N : <u>AFP4850S100-H</u>		Temperature : <u>23.6°C</u>	
Power Supply : <u>AC 230V/50Hz&amp;DC 450V, AC 230V/50Hz</u>		Humidity : <u>50%</u>	
Test Mode : <u>PV In&amp;AC Grid, AC Charging</u>			
Line : <input checked="" type="checkbox"/> AC Mains		Line : <input checked="" type="checkbox"/> DC Mains <input type="checkbox"/> Signal <input type="checkbox"/> I/O Cable	
Coupling : <input checked="" type="checkbox"/> Direct		Coupling : <input checked="" type="checkbox"/> Capacitive	
Test Time : 120s			
Line	Test Voltage	Result(+)	Result(-)
AC Mains	1kV	A	A
DC Line	0.5kV	A	A
Note:			

## 12. SURGE IMMUNITY TEST

### 12.1. Block Diagram of Test Setup

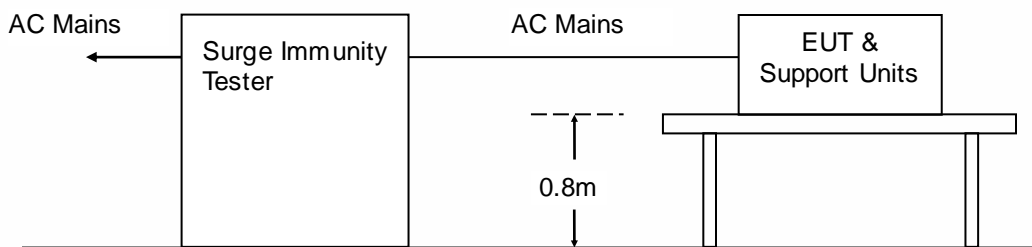

### 12.2. Test Standar

EN IEC 61000-6-1:2019  
(IEC 61000-4-5:2014)

### 12.3. Severity Levels and Performance Criterion

#### 12.3.1. Severity level

Severity Level	Open-Circuit Test Voltage kV
1	0.5
2	1.0
3	2.0
4	4.0
*	Special

#### 12.3.2. Performance criterion: B

### 12.4. Test Procedure

- 1) Set up the EUT and test generator as shown on Section 12.1.
- 2) For line to line coupling mode, provide a 1.0 kV 1.2/50us voltage surge (At open-circuit condition) and 8/20us current surge to EUT selected points.
- 3) At least 5 positive and 5 negative (polarity) tests with a maximum 1/min repetition rate are conducted during test.
- 4) Different phase angles are done individually.
- 5) Record the EUT operating situation during compliance test and decide the EUT immunity criterion for above each test.

### 12.5. Test Results

**PASS.**

Please refer to the following page.



## 13. INJECTED CURRENTS SUSCEPTIBILITY TEST

### 13.1. Block Diagram of Test Setup

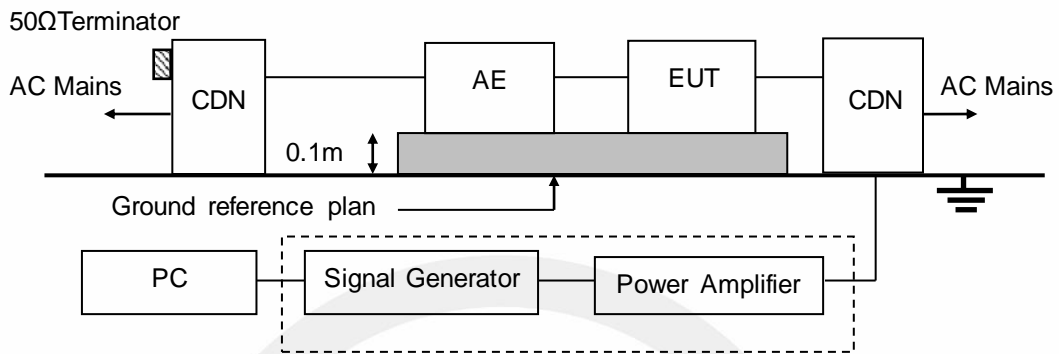

### 13.2. Test Standard

EN IEC 61000-6-1:2019

(IEC 61000-4-6:2013, Severity Level: Level 2, 3V (r.m.s.), 0.15MHz ~ 80MHz)

### 13.3. Severity Levels and Performance Criterion

#### 13.3.1. Severity level

Level	Field Strength V
1	1
2	3
3	10
X	Special

#### 13.3.2. Performance criterion: A

### 13.4. Test Procedure

- 1) Set up the EUT, CDN and test generators as shown on Section 13.1.
- 2) Let the EUT work in test mode and measure it.
- 3) The EUT are placed on an insulating support 0.1 m high above a ground reference plane. CDN (coupling and decoupling device) is placed on the ground plane about 0.3m from EUT. Cables between CDN and EUT are as short as possible, and their height above the ground reference plane shall be between 30 and 50 mm (where possible).
- 4) The disturbance signal described below is injected to EUT through CDN.
- 5) The EUT operates within its operational mode(s) under intended climatic conditions after power on.
- 6) The frequency range is swept from 150kHz to 80MHz using 3V signal level, and with the disturbance signal 80% amplitude modulated with a 1kHz sine wave.
- 7) The rate of sweep shall not exceed  $1.5 \times 10^{-3}$  decades/s. where the frequency is swept incrementally; the step size shall not exceed 1% of the start and thereafter 1% of the preceding frequency value.
- 8) Recording the EUT operating situation during compliance testing and decide the EUT immunity criterion.

### 13.5. Test Results

**PASS.**

Please refer to the following page.

## Injected Currents Susceptibility Test Results

EMTEK (SHENZHEN) CO., LTD.

Applicant : <u>SRNE Solar Co., Ltd</u>				
EUT : <u>Solar Storage Inverter</u>			Test Date: <u>2025-05-25</u>	
M/N : <u>AFP4850S100-H</u>			Temperature : <u>23.6°C</u>	
Power Supply : <u>AC 230V/50Hz&amp;DC 450V, AC 230V/50Hz</u>			Humidity : <u>50%</u>	
Test Mode: <u>PV In&amp;AC Grid, AC Charging</u>				
Frequency Range (MHz)	Injected Position	Strength (Unmodulated)	Criterion	Result
0.15 ~ 80	AC Mains	3V	A	A
0.15 ~ 80	DC Line	3V	A	A
Test Mode : <u>N/A</u>				
Frequency Range (MHz)	Injected Position	Strength (Unmodulated)	Criterion	Result
Remark : 1. Modulation Signal:1kHz 80% AM			Note:	

## 14. MAGNETIC FIELD SUSCEPTIBILITY TEST

### 14.1. Block Diagram of Test Setup

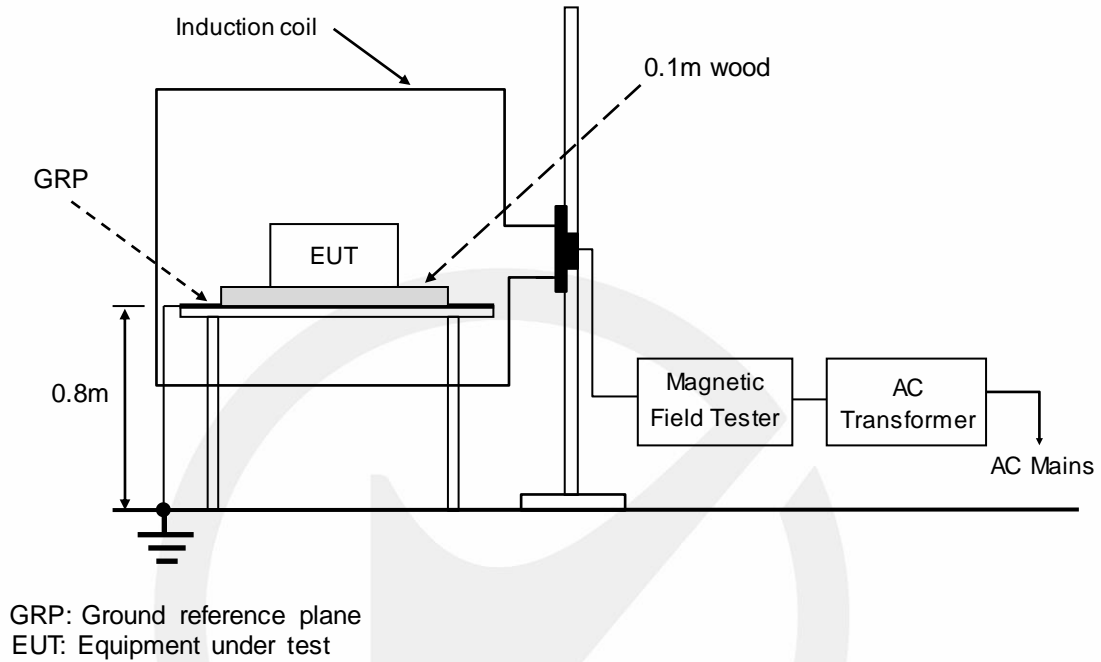

### 14.2. Test Standard

EN IEC 61000-6-1:2019  
(IEC 61000-4-8:2009, Severity Level: Level 2, 3A/m)

### 14.3. Severity Levels and Performance Criterion

#### 14.3.1. Severity Levels

Level	Field Strength A/m
1	1
2	3
3	10
4	30
5	100
X	Special

#### 14.3.2. Performance Criterion: A

#### 14.4. Test Procedure

The EUT is placed in the middle of a induction coil (1\*1m), under which is a 1\*1\*0.1m (high) table, this small table is also placed on a larger table, above the ground. Both horizontal and vertical polarization of the induction coil is set on test, so that each side of the EUT is affected by the magnetic field. Also can reach the same aim by change the position of the EUT.

#### 14.5. Test Results

**PASS.**

Please refer to the following page.



## Magnetic Field Immunity Test Result

EMTEK (SHENZHEN) CO., LTD.

Standard: <input checked="" type="checkbox"/> IEC 61000-4-8		Result: <input checked="" type="checkbox"/> PASS / <input type="checkbox"/> FAIL		
Applicant : <u>SRNE Solar Co., Ltd</u> EUT : <u>Solar Storage Inverter</u> M/N : <u>AFP4850S100-H</u> Input Voltage : <u>AC 230V/50Hz&amp;DC 450V, AC 230V/50Hz, DC 48V</u> Date of Test : <u>2025-05-25</u> Ambient Condition : Temp : <u>23.6°C</u> Humid: <u>50%</u> Criterion: A				
Operation Mode: PV In&AC Grid, AC Charging, Discharging&AC Back Up				
Test Level (A/m)	Testing Duration	Coil Orientation	Criterion	Result
3	5 mins	X	A	A
3	5 mins	Y	A	A
3	5 mins	Z	A	A
Operation Mode: N/A				
Test Level (A/m)	Testing Duration	Coil Orientation	Criterion	Result
Note:				

## 15. VOLTAGE DIPS AND INTERRUPTIONS TEST

### 15.1. Block Diagram of Test Setup

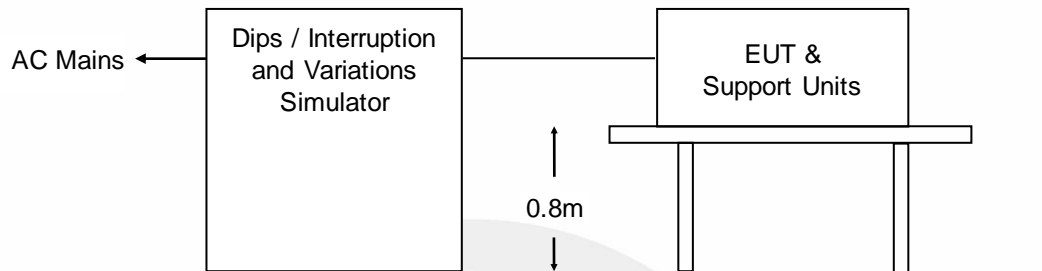

### 15.2. Test Standard

EN IEC 61000-6-1:2019 (IEC 61000-4-34:2005+A1:2009)

### 15.3. Severity Levels and Performance Criterion

#### 15.3.1. Severity level

Test Level %UT	Voltage dip and short interruptions %UT	Duration (in period)
0	100	0.5
70	30	1
		5
		10
		25
0	100	50
		*

#### 15.3.2. Performance criterion: B&C

### 15.4. Test Procedure

- 1) Set up the EUT and test generator as shown on Section 15.1.
- 2) The interruption is introduced at selected phase angles with specified duration.
- 3) Record any degradation of performance.

### 15.5. Test Results

**PASS.**

Please refer to the following page.

## Voltage Dips and Interruptions Test Results

EMTEK (SHENZHEN) CO., LTD.

Applicant : SRNE Solar Co., Ltd

EUT : Solar Storage Inverter

M/N : AFP4850S100-H

Power Supply : AC 230V/50Hz

Test Mode: AC Charging

Test Date : 2025-05-25

Temperature : 23.6°C

Humidity : 50%

Test Level % U <sub>T</sub>	Voltage Dips & Short Interruptions % U <sub>T</sub>	Duration (in periods)	Criterion <input type="checkbox"/> A <input checked="" type="checkbox"/> B <input checked="" type="checkbox"/> C <input type="checkbox"/> D	Result
0	100	0.5P	B	A
0	100	1P	B	A
70	30	25P	C	A
0	100	250P	C	B

Note: When it fell by 0%, the prototype was powered off at 250P. The mode was switched and it automatically resumed after the test was completed.

## 16. PHOTOGRAPHS

### 16.1. Photos of Conducted Emission Measurement



## 16.2.Photos of Radiation Emission Measurement

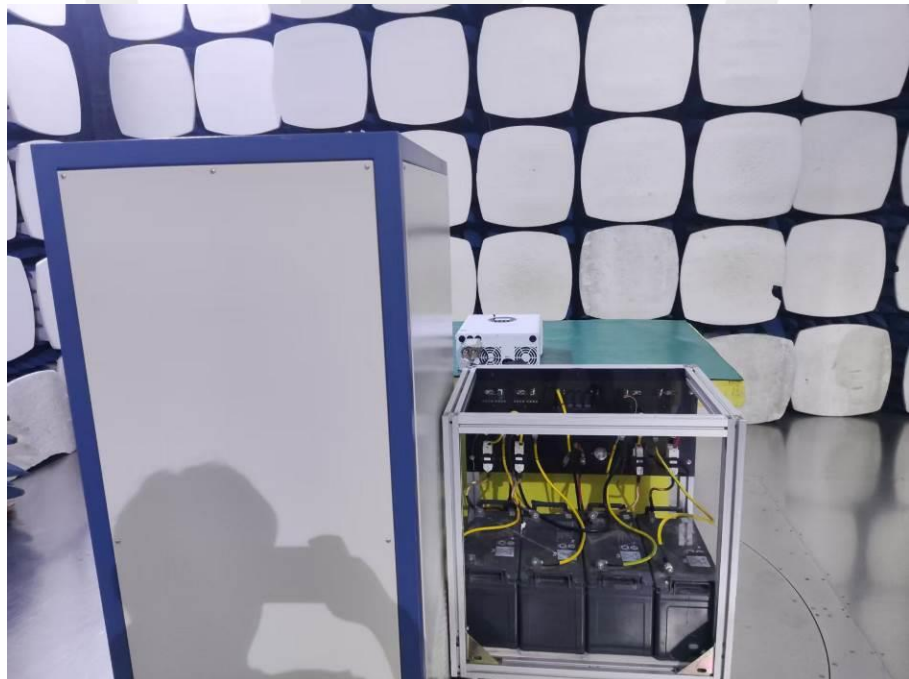

### 16.3. Photo of Harmonic / Flicker Measurement



### 16.4. Photo of Electrostatic Discharge Test



16.5. Photo of RF Field Strength Susceptibility Test



16.6. Photo of Electrical Fast Transient / Burst Test





16.7.Photo of Surge Test





16.8.Photo of Injected Currents Susceptibility Test





16.9. Photo of Magnetic Field Immunity Test

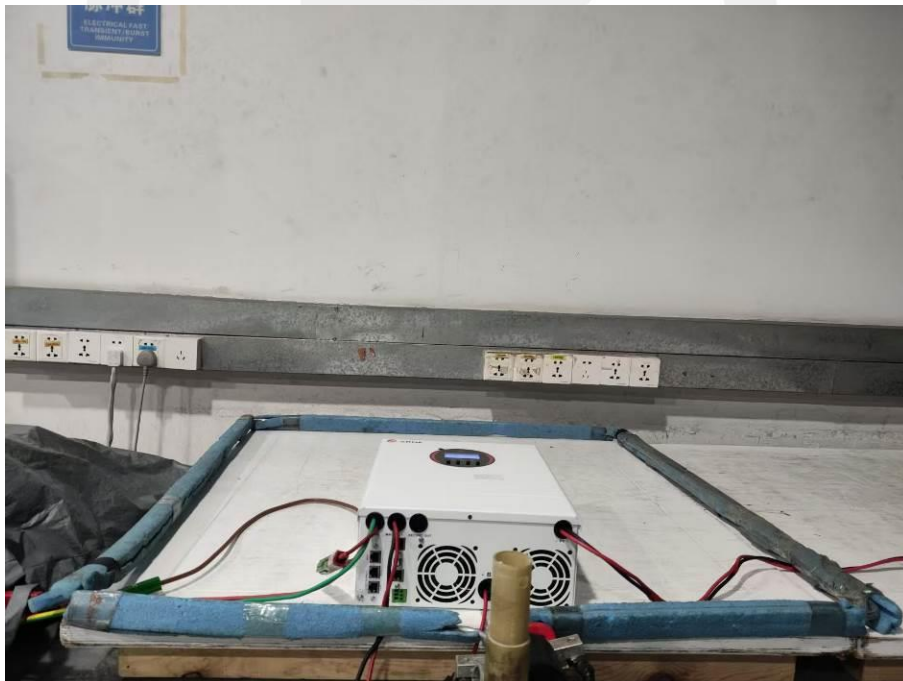

### 16.10.Photo of Voltage Dips and Interruption Immunity Test



## APPENDIX (Photos of EUT)

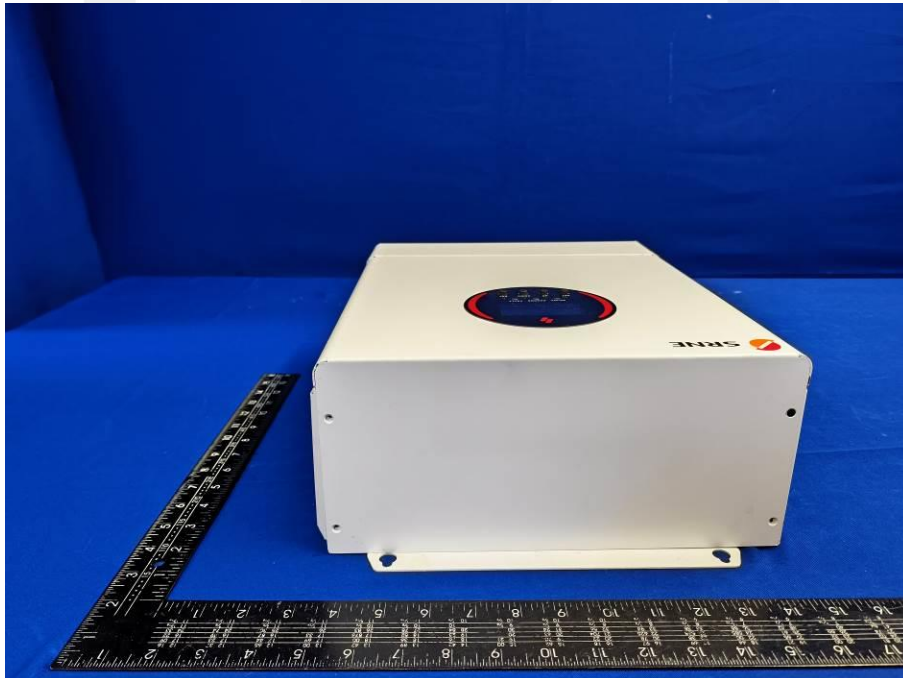
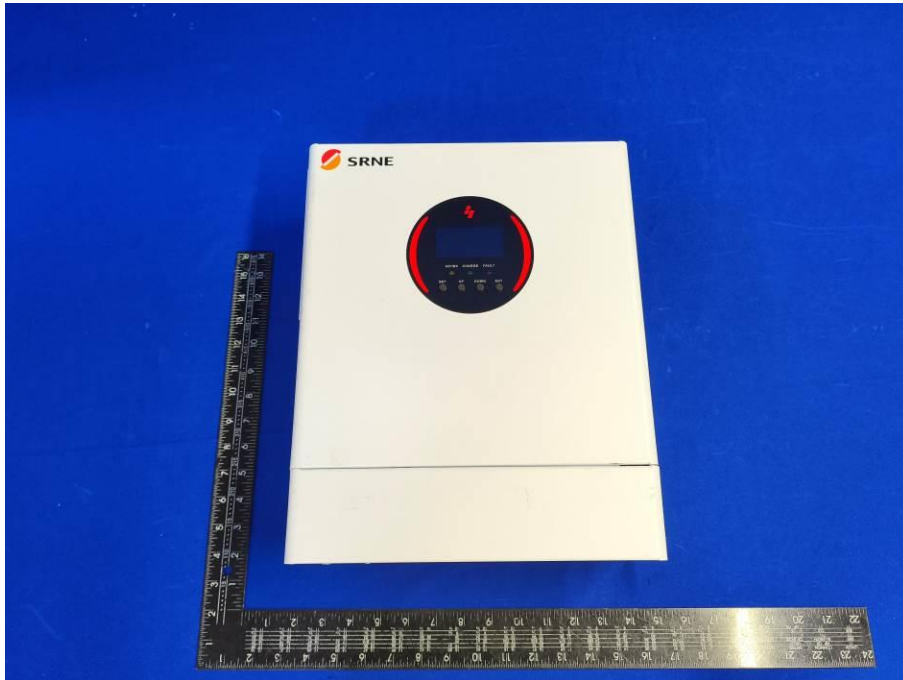

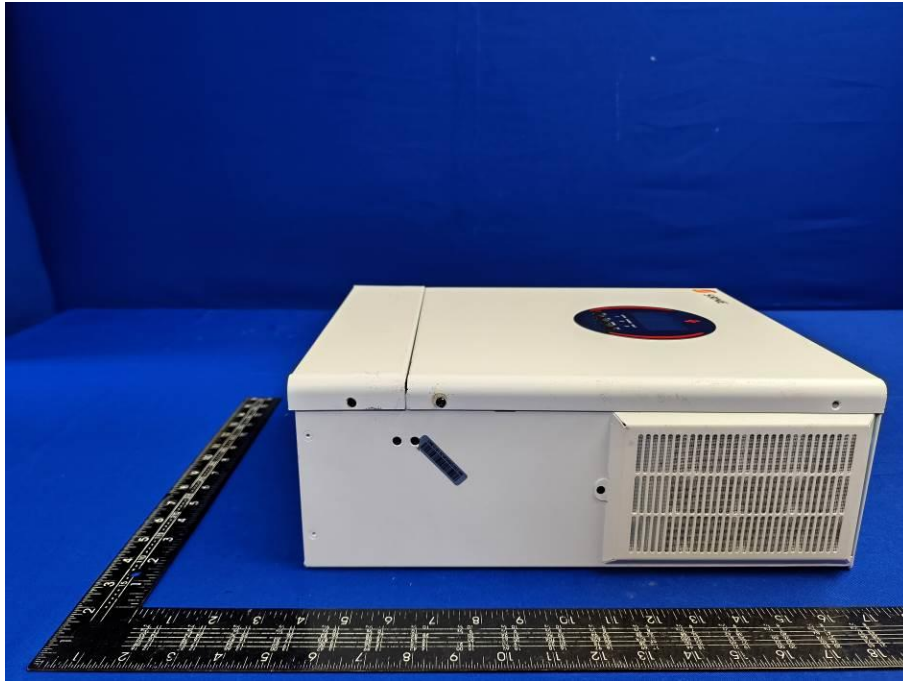



\*\*\*End of Report\*\*\*

## Statement

- 1 . This report is invalid without the signature of the authorized approver and "special seal for testing".
- 2 . This report shall not be copied partly without authorization.
- 3 . The test results or observations are applicable only to tested sample. Client shall be responsible for representativeness of the sample and authenticity of the material.
- 4 . The observations or tests with special mark fall outside the scope of accreditation, and are only used for purpose of commission, research, training, internal quality control etc.
- 5 . The test results or observations are provided in accordance with measured value, without taking risks caused by uncertainty into account. Without explicit stipulation in special agreements, standards or regulations, EMTEK shall not assume any responsibility.
- 6 . Objections shall be raised within 20 days from the date receiving the report.