

# User Manual



## Solar storage inverter

**SPI-4K-UP**

**SPI-5K-UP**

**SPI-6K-UP**

**SPI-6.5K-UP**

# Contents

<b>1. Safety</b> .....	<b>1</b>
1.1 About this Manual.....	1
1.2 Symbols and description.....	1
1.3 Safety matters.....	1
<b>2. About the Product</b> .....	<b>2</b>
2.1 Description.....	2
2.2 Features.....	2
2.3 System connection diagram.....	3
2.4 Product overview.....	4
<b>3. Installation</b> .....	<b>5</b>
3.1 Installation location.....	5
3.2 Inverter installation.....	6
3.3 Removal of terminal cover and insect-proof net.....	6
<b>4. Wiring</b> .....	<b>7</b>
4.1 Wiring mode (depends on the output mode).....	7
4.2 Cable and circuit breaker model.....	10
4.3 GRID 、LOAD and Gen wiring.....	14
4.4 Battery wiring.....	14
4.5 PV wiring.....	15
4.6 Dry contact wiring.....	15
4.7 Grounding.....	16
4.8 Inverter start.....	16
4.9 Parallel wiring.....	16
4.9.1 Parallel operation.....	16
4.9.2 Cautions for parallel connection.....	17
4.9.3Wiring diagram for single-phase parallel connection (phase difference between L1 and L2: 0°).....	18
4.9.4 Wiring diagram for two-phase parallel connection (phase difference between L1 and L2: 0°).....	21
4.9.5 Wiring diagram for split-phase parallel connection (phase difference between L1 and L2: 180°).....	26
4.9.6 Wiring diagram for three-phase parallel connection.....	28
<b>5. Operation</b> .....	<b>33</b>
5.1 Operation and display panel.....	33
5.2 Setting.....	38





5.5 Timed charge/discharge function .....	47
5.6 Battery parameters .....	48
<b>6. Communication .....</b>	<b>50</b>
6.1 Overview .....	50
6.2 USB-B port .....	50
6.4 RS485/CAN port .....	51
6.5 CT port (optional) .....	52
6.6 Dry contact port .....	53
<b>7. Fault Codes and Response Measures .....</b>	<b>54</b>
7.1 Fault codes .....	54
7.2 Troubleshooting .....	57
<b>8. Protection Function and Product Maintenance .....</b>	<b>59</b>
8.1 Protection function .....	59
8.2 Maintenance .....	61
<b>9. Data sheet .....</b>	<b>62</b>

# 1. Safety

## 1.1 About this Manual

- This Manual contains important information, guiding principles, operation, and maintenance of the product, and applies to the model: SPI UP series
- Users must follow the instructions in this Manual during installation, use, and maintenance

## 1.2 Symbols and description

Symbol	Description
	Dangerous situations that will lead to death or serious injury when ignored
	Dangerous situations that may lead to death or serious injury when ignored
	Dangerous situations that may lead to mild or moderate injury when ignored
	Operation tips

## 1.3 Safety matters

### **DANGER**

- This chapter contains important safety matters. Please read and keep this Manual for future reference.
- Please make sure to comply with local requirements and regulations when installing the inverter.
- Be careful of high voltage. Before and during installation, please turn off the switch of each power supply to avoid electric shock.
- In order to achieve optimal operation of the inverter, please select the appropriate cable size and necessary protective devices according to regulations.
- Do not connect or disconnect any connections when the inverter is working.
- Do not open the terminal cover when the inverter is working.

## 2. About the Product

### 2.1 Description

SPI UP series is a new type of solar storage inverter that integrates PV storage, mains charge, and energy storage and outputs sinusoidal AC. Equipped with DSP control and advanced control algorithm, it has high response speed and good reliability, and applies to industrial scenarios.

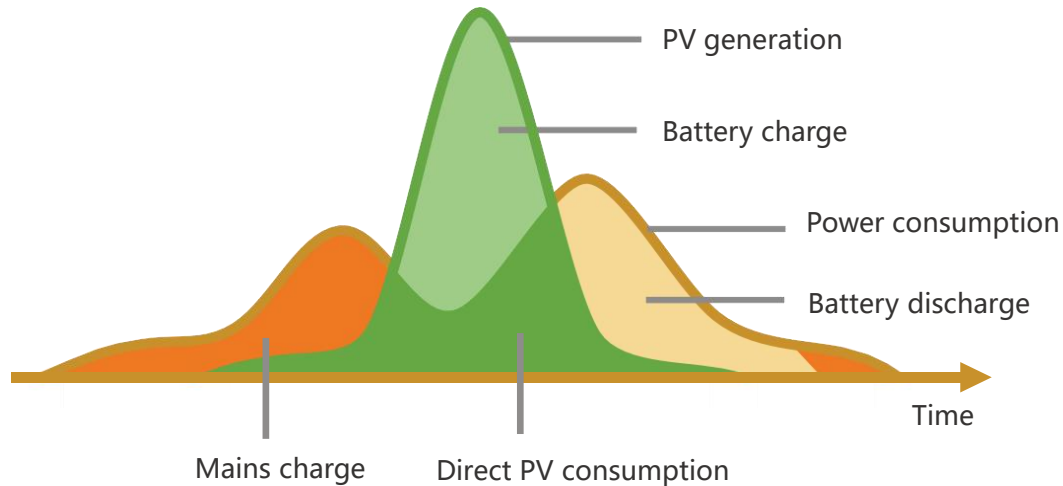

### 2.2 Features

- Support the connection of various types of energy storage batteries such as lead-acid battery and lithium-ion battery
- Have the dual activation function during lithium-ion battery sleep, that is, access to mains/PV power can activate the lithium-ion battery
- Support split-phase/single-phase pure sine wave output
- Support adjusting the voltage of each phase within the range of 100 Vac, 105 Vac, 110 Vac, 120 Vac and 127Vac
- Support two-channel PV input and have the function of simultaneous two-channel maximum power point tracking (MPPT) for charging/carrying capacity
- Support two-channel MPPT, with an efficiency of up to 99.9% and a maximum single-channel current of 18 A, perfectly fitting high-power modules
- Provide four charge modes: only PV, mains first, PV first, and mains + PV
- Have the timed charge and discharge function, that is, users can set the charge and discharge time according to the time-of-use price to save electricity costs
- Have the energy-saving mode, reducing no-load energy losses
- Provide two output modes: mains bypass output and inverter output, achieving uninterrupted power supply
- Support LCD display of dynamic flowchart, updating system data and operating status at any time
- Provide 360 ° protection, including short circuit protection, overcurrent protection, overvoltage and undervoltage protection, and overload protection
- Support CAN, USB, RS485 communication

## 2.3 System connection diagram

The following figure shows the system application scenario of the product. A complete system consists of the following parts:

1. **PV module:** It converts solar energy into DC to charge batteries or into AC to supply power to loads.
  2. **Mains or generator:** Connected to AC input, it can charge batteries while supplying power to loads. When the battery and PV module supply power to the load, the system can generally operate without mains or generator.
  3. **Battery:** The function of a battery is to ensure normal power supply for the system load when there is insufficient PV power and no mains.
  4. **Household load:** It can connect various household and office loads, including refrigerators, lighting fixtures, TVs, fans, air conditioners, and other AC loads.
  5. **Inverter:** It is the energy conversion device of the entire system.
- **The actual application scenario determines the specific system wiring mode**

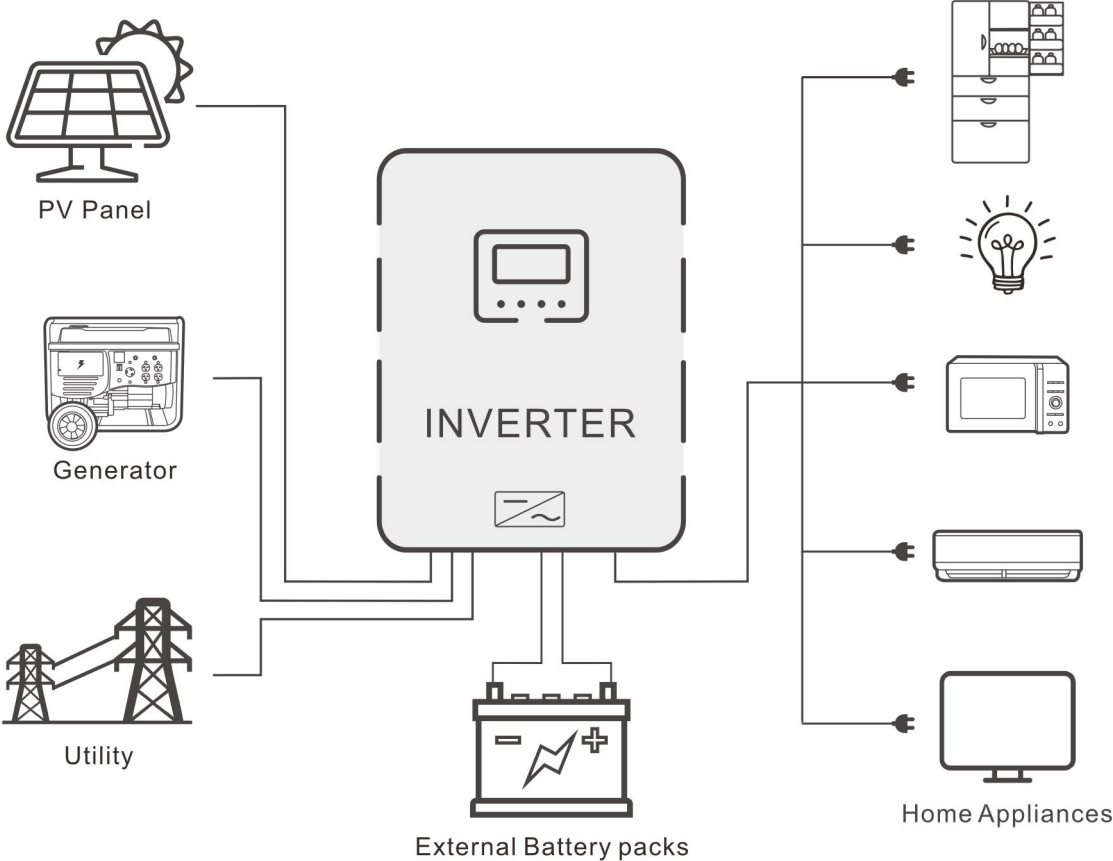

## 2.4 Product overview

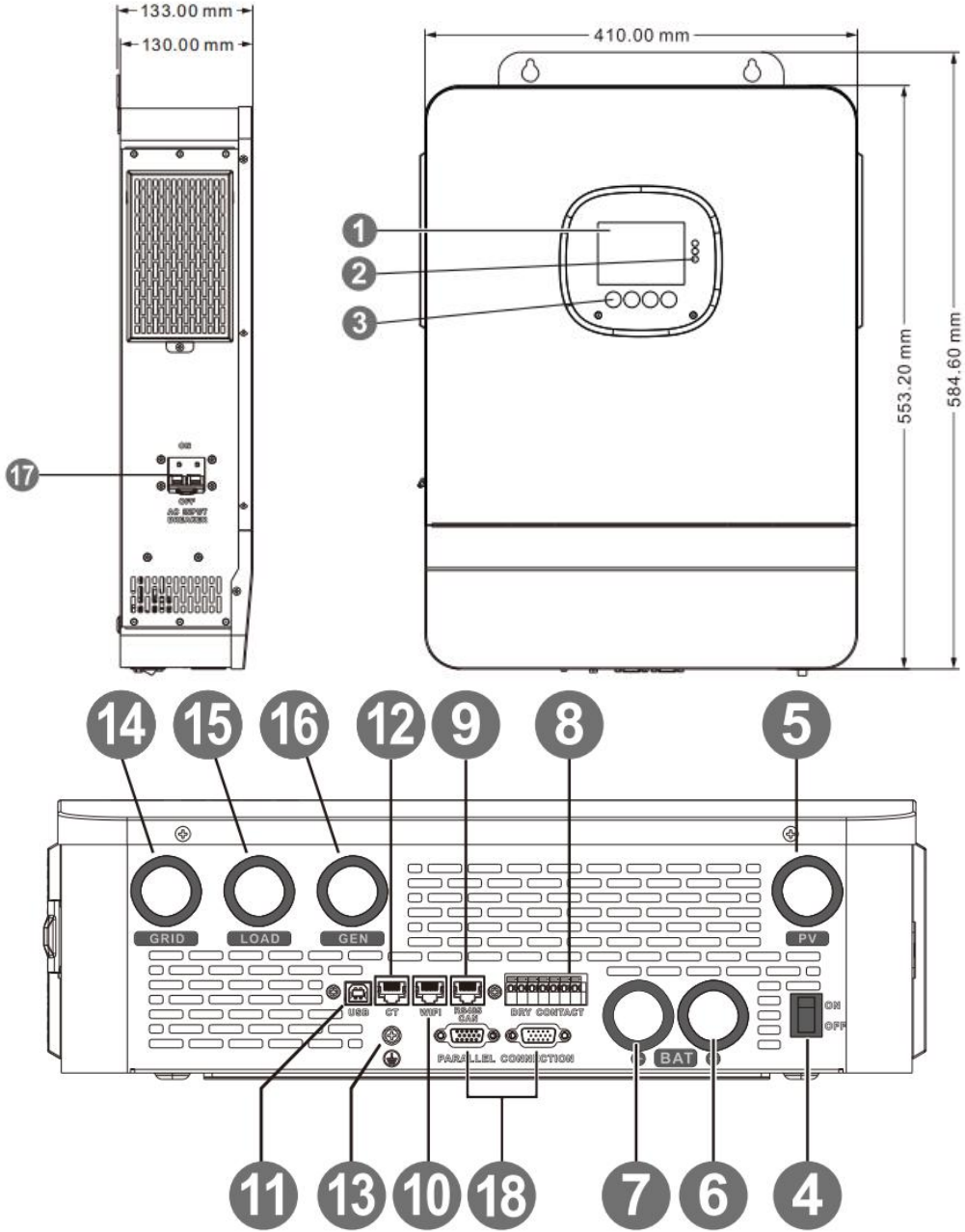

1	LCD screen	2	Physical button	3	LED indicator
4	ON/OFF rocker switch	5	PV input	6	Battery (positive electrode)
7	Battery (negative electrode)	8	Dry contact	9	RS485/CAN port
10	WIFI port	11	USB-B port	12	CT
13	Grounding screw	14	AC output (L1+L2+N)	15	AC input (L1+L2+N)
16	Generator input(L1+L2+N)	17	AC input circuit breaker	18	Parallel communication port

# 3. Installation

## 3.1 Installation location

SPI UP series is only for indoor use (**protection level: IP20**). Before selecting the installation location, users should consider the following factors:

- A solid wall
- Installation height: flush with the line of sight
- Sufficient heat dissipation space
- Ambient temperature:  $-10^{\circ}\text{C}$ – $55^{\circ}\text{C}$  ( $14^{\circ}\text{F}$ – $131^{\circ}\text{F}$ ), to ensure optimal operation

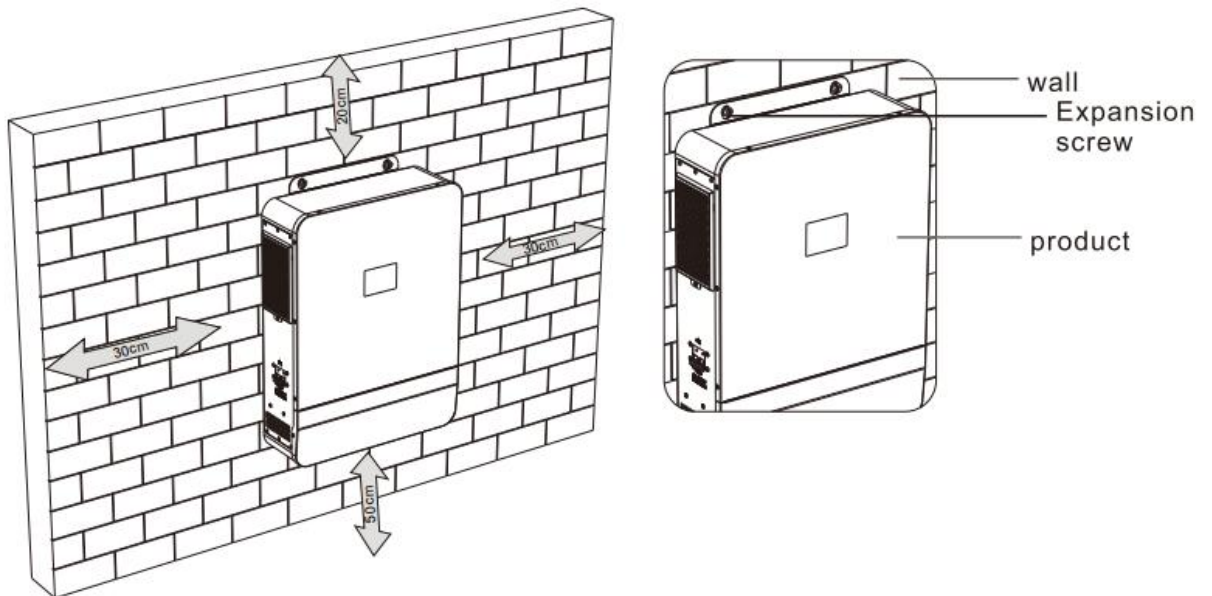

### **⚠ DANGER**

- Do not install the inverter near highly flammable materials
- Do not install the inverter in potentially explosive areas
- Do not install the inverter and lead-acid battery in enclosed spaces

### **⚠ CAUTION**

- Do not install the inverter in direct sunlight
- Do not install or use the inverter in damp environments

### 3.2 Inverter installation

Drill 4 installation holes of the specified sizes on the wall with an electric drill, insert 2 expansion screws above, and fix the inverter with 2 M5 screws below.

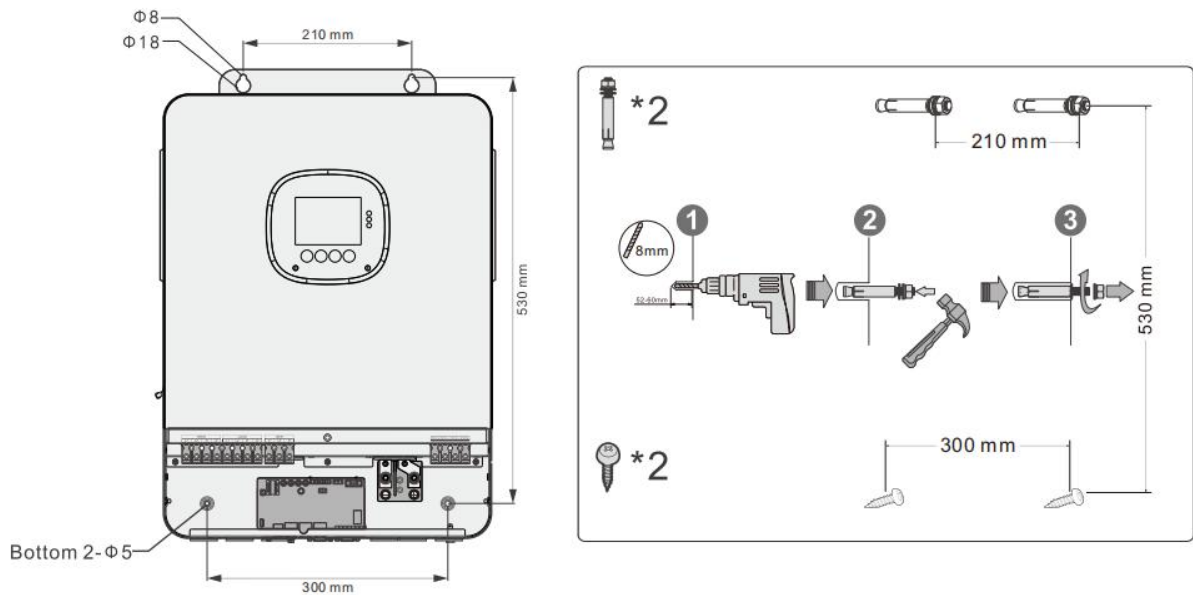

### 3.3 Removal of terminal cover and insect-proof net

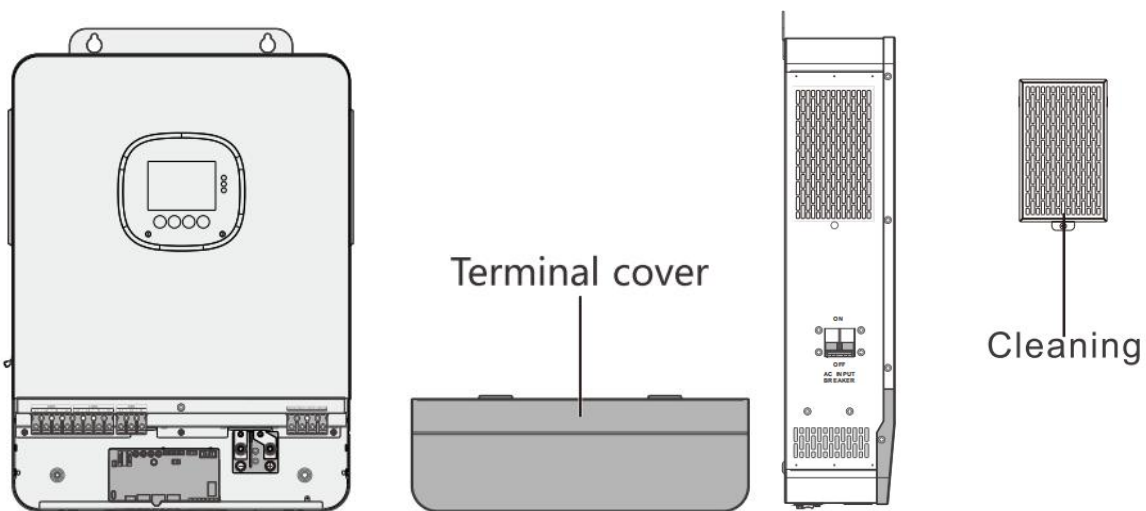

#### NOTICE

- When using the inverter in areas with poor air quality, the dustproof net is easily blocked by air particles. Please regularly remove and clean it to avoid affecting the air flow rate inside the inverter; otherwise it may cause inverter overheating (19/20 fault), and affect power supply and the service life of the inverter

# 4. Wiring

## 4.1 Wiring mode (depends on the output mode)

- Split-phase mode (default)

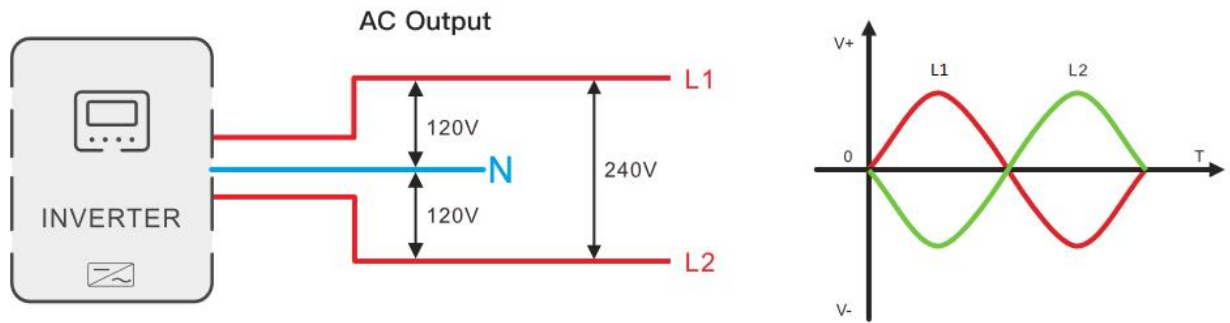

Item	Description
Applicable model	SPI UP series
AC output phase voltage (L-N)	100 VAC–120 VAC, 120 VAC (default)
AC output line voltage (L-L)	200 VAC–240 VAC, 240 VAC (default)

- Single-phase mode

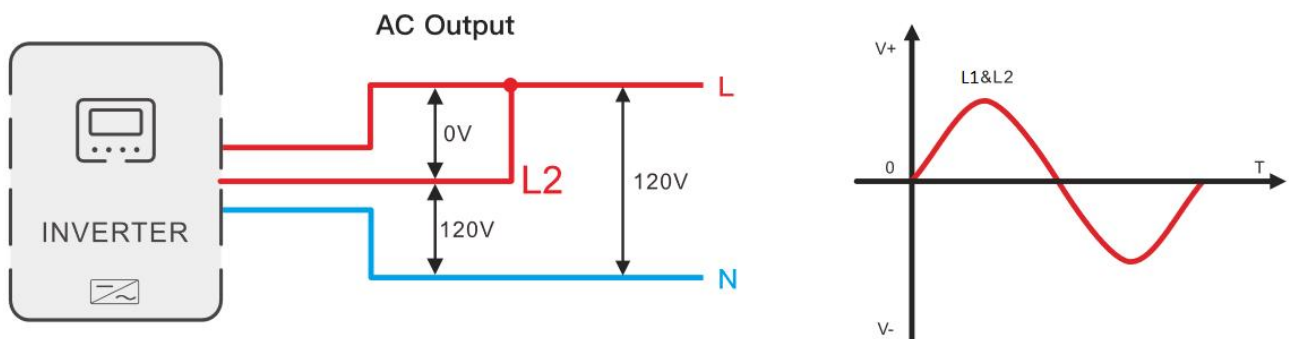

Item	Description
Applicable model	SPI UP series
AC output phase voltage (L-N)	100 VAC–120 VAC, 120 VAC (default)

# Split-phase Mode

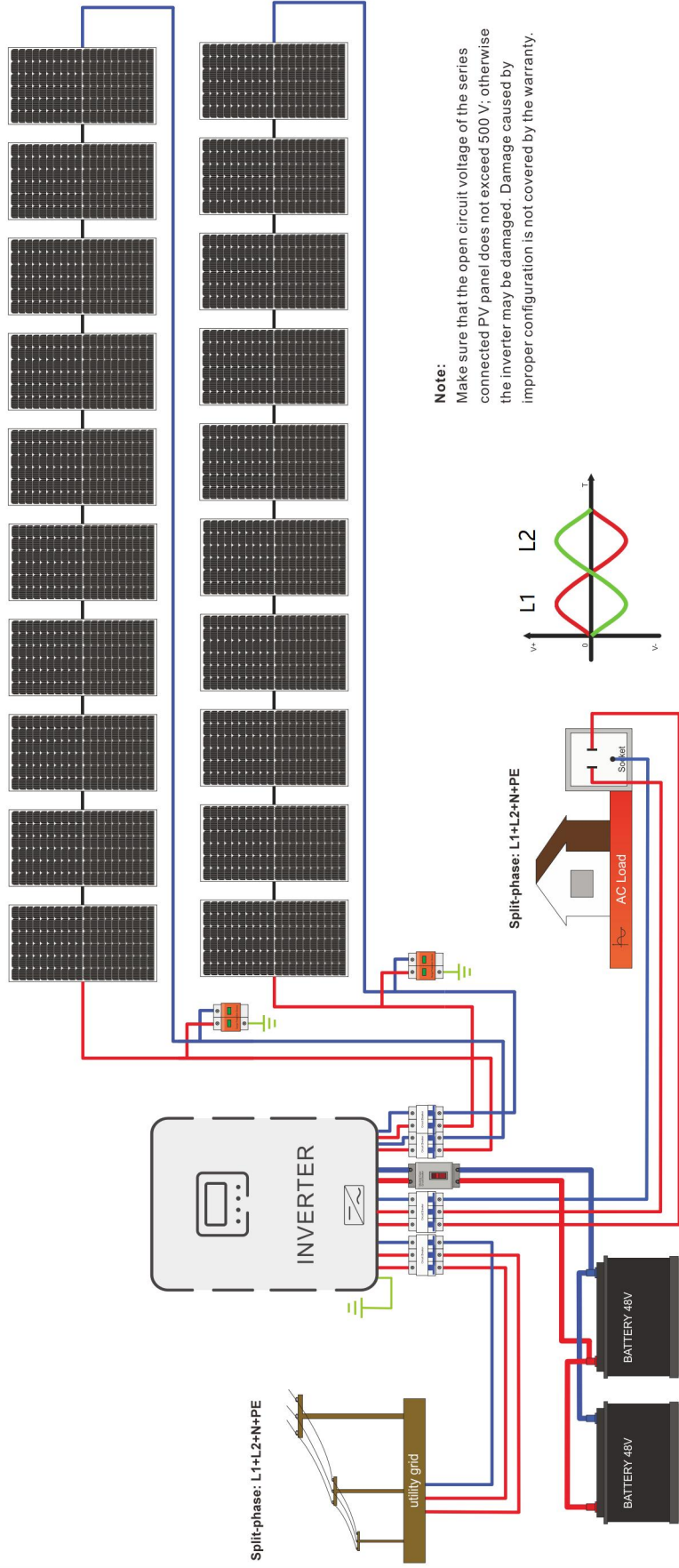

**Note:**

Make sure that the open circuit voltage of the series connected PV panel does not exceed 500 V; otherwise the inverter may be damaged. Damage caused by improper configuration is not covered by the warranty.

Split-phase: L1+L2+N+PE

Split-phase: L1+L2+N+PE

# Single-phase Mode

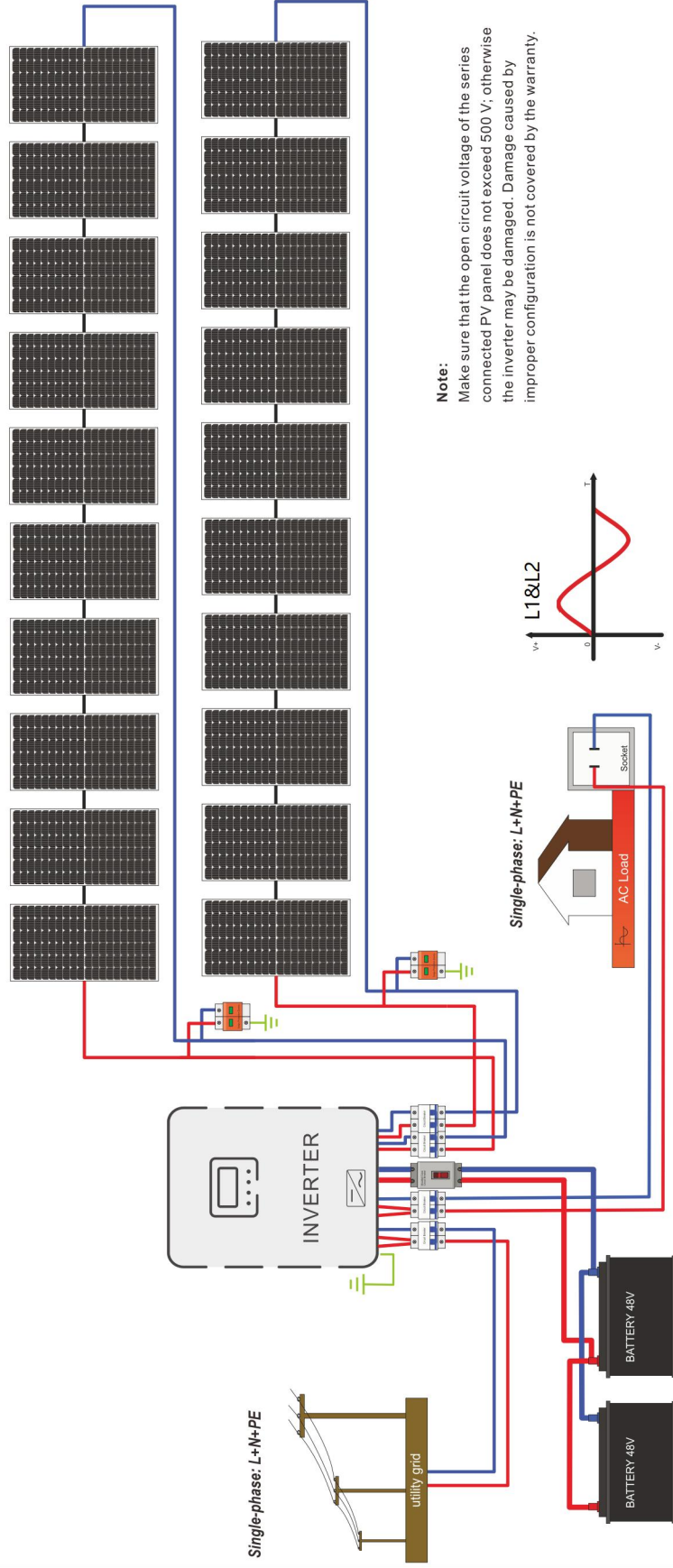

**Note:**





Make sure that the open circuit voltage of the series connected PV panel does not exceed 500 V; otherwise the inverter may be damaged. Damage caused by improper configuration is not covered by the warranty.

## 4.2 Cable and circuit breaker model

- PV INPUT**

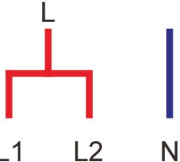

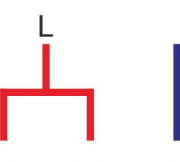

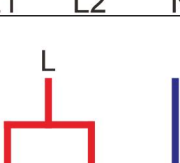
Inverter Model	Cable Size	Maximum Input Current	Circuit Breaker Model
SPI-4K-UP	4mm <sup>2</sup> /12AWG	18A/18A	2P-25A
SPI-5K-UP			
SPI-6K-UP			
SPI-6.5K-UP			

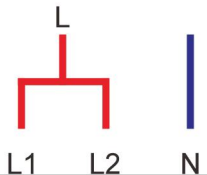
- Grid input**

Inverter Model	Output Mode	Diagram	Maximum Current	Cable Size	Circuit Breaker Model
SPI-4K-UP	Split-phase mode		40A(L1/L2/N)	10mm <sup>2</sup> /8AWG (L1\L2\N)	3P-40A
	Single-phase mode		40A(L1/L2) 80A(N)	10mm <sup>2</sup> /8AWG(L1/L2) 20mm <sup>2</sup> /4AWG(N)	2P-80A
SPI-5K-UP	Split-phase mode		40A(L1/L2/N)	10mm <sup>2</sup> /8AWG (L1\L2\N)	3P-40A
	Single-phase mode		40A(L1/L2) 80A(N)	10mm <sup>2</sup> /8AWG(L1/L2) 20mm <sup>2</sup> /4AWG(N)	2P-80A
SPI-6K-UP	Split-phase mode		40A(L1/L2/N)	10mm <sup>2</sup> /8AWG (L1\L2\N)	3P-40A
	Single-phase mode		40A(L1/L2) 80A(N)	10mm <sup>2</sup> /8AWG(L1/L2) 20mm <sup>2</sup> /4AWG(N)	2P-80A

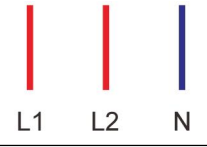
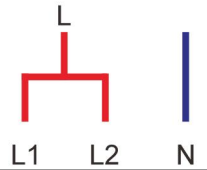
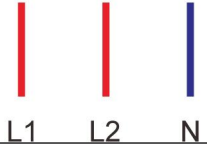
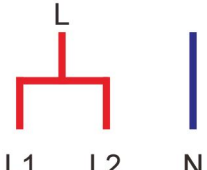
SPI-6.5K-UP	Split-phase mode		40A(L1/L2/N)	10mm <sup>2</sup> /8AWG (L1\L2\N)	3P-40A
	Single-phase mode		40A(L1/L2) 80A(N)	10mm <sup>2</sup> /8AWG(L1/L2) 20mm <sup>2</sup> /4AWG(N)	2P-80A

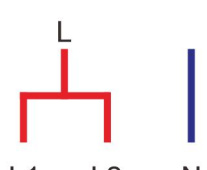
- Generator input**

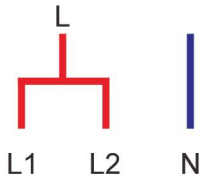

Inverter Model	Output Mode	Diagram	Maximum Current	Cable Size	Circuit Breaker Model
SPI-4K-UP	Split-phase mode		40A(L1/L2/N)	10mm <sup>2</sup> /8AWG (L1\L2\N)	3P-40A
	Single-phase mode		40A(L1/L2) 80A(N)	10mm <sup>2</sup> /8AWG(L1/L2) 16mm <sup>2</sup> /6AWG(N)	2P-80A
SPI-5K-UP	Split-phase mode		40A(L1/L2/N)	10mm <sup>2</sup> /8AWG (L1\L2\N)	3P-40A
	Single-phase mode		40A(L1/L2) 80A(N)	10mm <sup>2</sup> /8AWG(L1/L2) 16mm <sup>2</sup> /6AWG(N)	2P-80A
SPI-6K-UP	Split-phase mode		40A(L1/L2/N)	10mm <sup>2</sup> /8AWG (L1\L2\N)	3P-40A
	Single-phase mode		40A(L1/L2) 80A(N)	10mm <sup>2</sup> /8AWG(L1/L2) 16mm <sup>2</sup> /6AWG(N)	2P-80A
SPI-6.5K-UP	Split-phase mode		40A(L1/L2/N)	10mm <sup>2</sup> /8AWG (L1\L2\N)	3P-40A



	Single-phase mode		40A(L1/L2) 80A(N)	10mm <sup>2</sup> /8AWG(L1/L2) 16mm <sup>2</sup> /6AWG(N)	2P-80A
--	-------------------	---	----------------------	--	--------

- Battery**

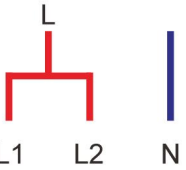
Inverter Model	Cable Size	Maximum Current	Circuit Breaker Model
SPI-4K-UP	35mm <sup>2</sup> /2AWG	120A	2P-160A
SPI-5K-UP	35mm <sup>2</sup> /2AWG	130A	2P-160A
SPI-6K-UP	35mm <sup>2</sup> /2AWG	150A	2P-160A
SPI-6.5K-UP	35mm <sup>2</sup> /2AWG	150A	2P-160A

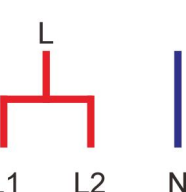
- AC output**

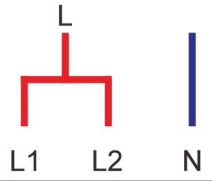
Inverter Model	Output Mode	Diagram	Maximum Current	Cable Size	Circuit Breaker Model
SPI-4K-UP	Split-phase mode		40A(L1/L2/ N)	10mm <sup>2</sup> /8AWG (L1\L2\N)	3P-40A
	Single-phase mode		40A(L1/L2) 80A(N)	10mm <sup>2</sup> /8AWG(L1/L2) 16mm <sup>2</sup> /6AWG(N)	2P-80A
SPI-5K-UP	Split-phase mode		40A(L1/L2/ N)	10mm <sup>2</sup> /8AWG (L1\L2\N)	3P-40A
	Single-phase mode		40A(L1/L2) 80A(N)	10mm <sup>2</sup> /8AWG(L1/L2) 16mm <sup>2</sup> /6AWG(N)	2P-80A

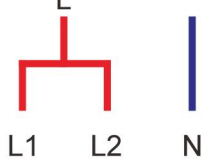
SPI-6K-UP	Split-phase mode		40A(L1/L2/N)	10mm <sup>2</sup> /8AWG (L1\L2\N)	3P-40A
	Single-phase mode		40A(L1/L2) 80A(N)	10mm <sup>2</sup> /8AWG(L1/L2) 16mm <sup>2</sup> /6AWG(N)	2P-80A
SPI-6.5K-UP	Split-phase mode		40A(L1/L2/N)	10mm <sup>2</sup> /8AWG (L1\L2\N)	3P-40A
	Single-phase mode		40A(L1/L2) 80A(N)	10mm <sup>2</sup> /8AWG(L1/L2) 16mm <sup>2</sup> /6AWG(N)	2P-80A

### NOTICE

#### ● PV input, AC input, and AC output terminals

1. Use a wire stripper to strip off 6 mm–8 mm long insulation layer of the cable.
2. Fix a sleeve at the end of the cable (the sleeve is to be prepared by the user)

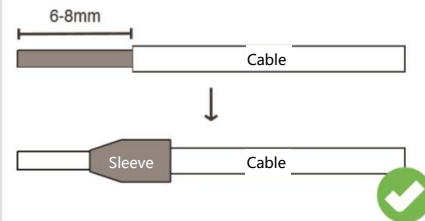

#### ● Battery terminal

1. Use a wire stripper to strip off 6 mm–8 mm long insulation layer of the cable.
2. Fix a ring terminal (attached) at the end of the cable

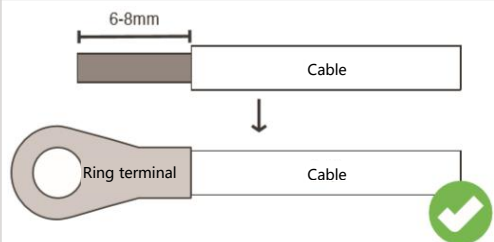

The cable size is for reference only. If the distance between the PV array and the inverter or between the inverter and the battery is long, using thicker cables will reduce voltage drop and improve system performance.

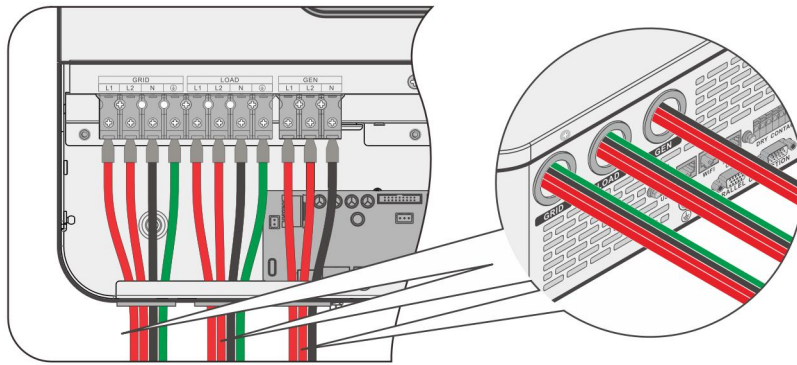

### 4.3 GRID 、LOAD and Gen wiring

Connect the live wire, neutral wire, and ground wire according to the cable position and sequence shown in the following figure.

#### **DANGER**

- Before connecting AC input and output, be sure to disconnect the circuit breaker to avoid the risk of electric shock. Do not conduct live operation.
- Please check whether the cables used are sufficient to meet the requirements. Cables that are too thin or of poor quality may pose serious safety hazards.

### 4.4 Battery wiring

Connect the positive and negative cables of the battery according to the cable position and sequence shown in the following figure

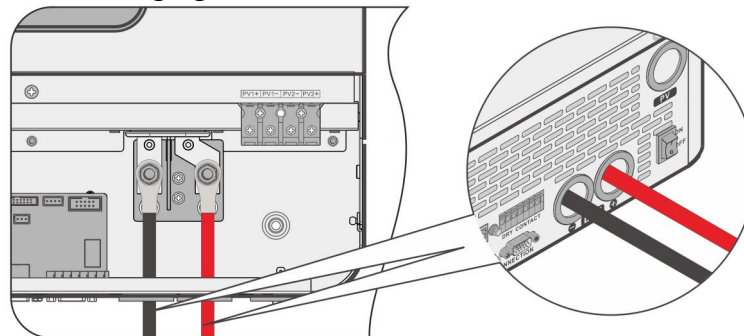

#### **DANGER**

- Before connecting the battery, be sure to disconnect the circuit breaker to avoid the risk of electric shock. Do not conduct live operation.
- Please check the positive and negative terminals of the battery for correct connection and no reverse connection; otherwise it may damage the inverter.
- Please check whether the cables used are sufficient to meet the requirements. Cables that are too thin or of poor quality may pose serious safety hazards.

## 4.5 PV wiring

Connect the positive and negative terminals of the two-channel PV modules according to the cable position and sequence shown in the following figure.

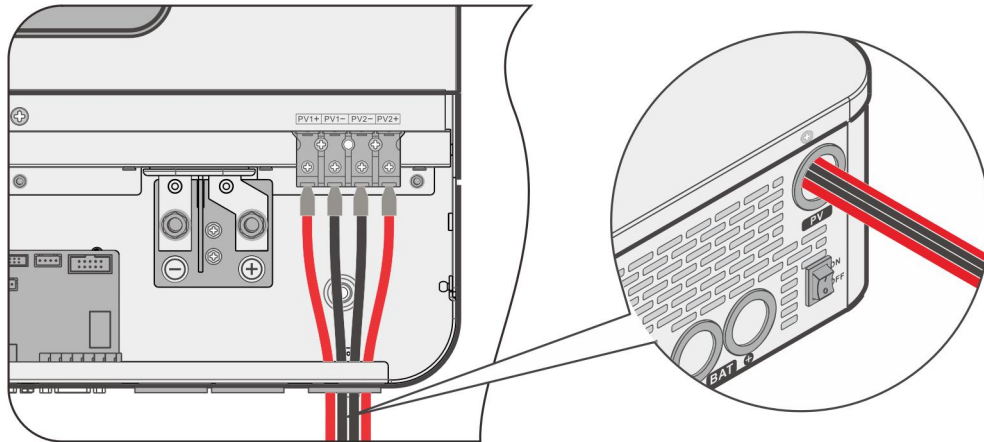

### **⚠ DANGER**

- Before connecting PV modules, be sure to disconnect the circuit breaker to avoid the risk of electric shock. Do not conduct live operation.
- Please make sure that the open circuit voltage of the series connected PV modules does not exceed the maximum open circuit voltage of the inverter (in ASP series, this value is 550 V); otherwise the inverter may be damaged.

## 4.6 Dry contact wiring

Use a small-sized screwdriver to push back in the direction indicated by the arrow, and then insert the communication cable into the dry contact port. (Communication cable section: 0.2 mm<sup>2</sup>–1.5 mm<sup>2</sup>)

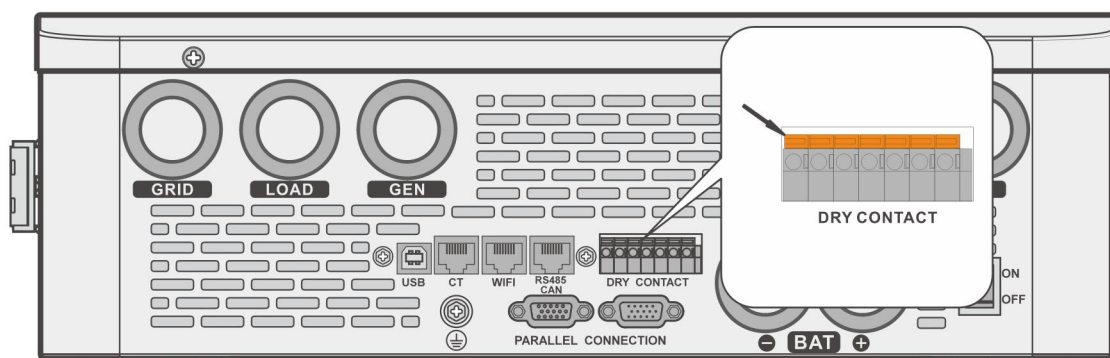

## 4.7 Grounding

Please ensure that the grounding terminal is reliably connected to the grounding busbar.

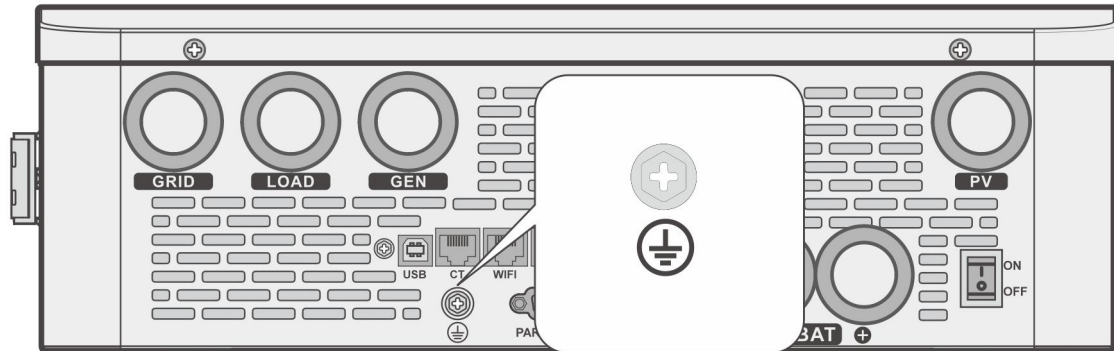

### NOTICE

- The grounding cable size shall not be less than 4 mm<sup>2</sup> and shall be as close as possible to the grounding point

## 4.8 Inverter start

After confirming reliable wiring and correct wiring sequence, restore the terminal cover to its original position

- Step 1: Close the circuit breaker of the battery
- Step 2: Press the rocker switch at the bottom of the inverter, and the screen and indicator will light up, indicating that the inverter is enabled
- Step 3: Close the circuit breakers for PV input, AC input, and AC output in sequence
- Step 4: Start loads one by one in order of power from small to large

## 4.9 Parallel wiring

### 4.9.1 Parallel operation

1. The parallel operation supports up to six solar storage inverters.
2. When using the parallel function, it is necessary to connect the parallel communication cable in a correct and reliable manner. See the figure below for the communication cable (packaging accessory):

#### Parallel communication cable\*1

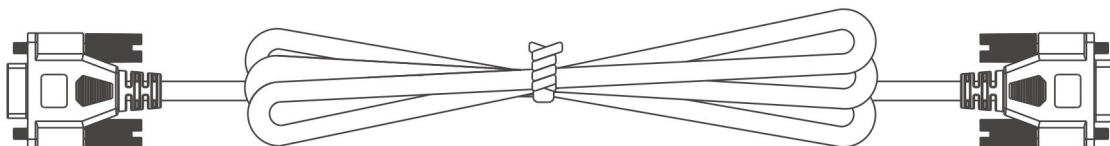

## 4.9.2 Cautions for parallel connection

### **Warning:**

#### 1. **PV wiring:**

In parallel connection, the PV array of each inverter must be independent, and the PV array of PV1 and PV2 for one inverter must also be independent.

#### 2. **Battery wiring**

In single-phase or three-phase parallel connection, all solar storage inverters must be connected to the same battery, with BAT+ connected to BAT+ and BAT- to BAT-, and before power on and start-up, it is necessary to check and ensure correct connection, wiring length, and cable size, so as to avoid the abnormal operation of parallel system output caused by wrong connection.

#### 3. **LOAD wiring:**

In single-phase parallel connection, all solar storage inverters must be connected in the manner of L-to-L, N-to-N, and PE-to-PE, and before power on and start-up, it is necessary to check and ensure correct connection, wiring length, and cable size, so as to avoid the abnormal operation of parallel system output caused by wrong connection.

In three-phase parallel connection, all solar storage inverters must be connected in the manner of N-to-N and PE-to-PE. The L lines of all inverters in the same phase shall be connected together, but the AC output L lines of different phases shall not be connected together. Other cautions are the same as those for single-phase parallel connection.

#### 4. **GRID and GEN wiring:**

In single-phase parallel connection, all solar storage inverters must be connected in the manner of L-to-L, N-to-N, and PE-to-PE, and before power on and start-up, it is necessary to check and ensure correct connection, wiring length, and cable size, so as to avoid the abnormal operation of parallel system output caused by wrong connection. Meanwhile, it is not allowed to have multiple different AC source inputs to avoid damage to the external equipment of the inverter. The AC source input shall be consistent and unique.

In three-phase parallel connection, all solar storage inverters must be connected in the manner of N-to-N and PE-to-PE. The L lines of all inverters in the same phase shall be connected together, but the AC output L lines of different phases shall not be connected together. Other cautions are the same as those for single-phase parallel connection.

#### 5. **Communication wiring:**

Our company's communication cable for parallel operation is a DB15 standard computer cable with shielding function, and it is used for single-phase or three-phase parallel connection. Each inverter shall be connected with one out and one in, that is, the male connector (out) of the inverter is to be connected to the female connector (in) of the parallel inverter, not the one of the inverter. In addition, DB15 terminal screws will be used to tighten the communication cable of each parallel inverter to avoid falling off or poor contact of the communication cable, followed by abnormal operation or damage of the system output.

#### 6. Before and after connecting the system, please carefully refer to the following system wiring diagrams to ensure that all wiring is correct and reliable before power on.

7. After the system is correctly wired, powered on, and in normal operation, if a new inverter needs to be connected, make sure to disconnect the battery input, PV input, AC input and AC output, and that all solar storage inverters are powered off before reconnecting into the system.

#### 4.9.3 Wiring diagram for single-phase parallel connection (phase difference between L1 and L2: 0°)

- The communication cable of parallel solar storage inverter is to be locked with screws after connecting. See the diagram below:

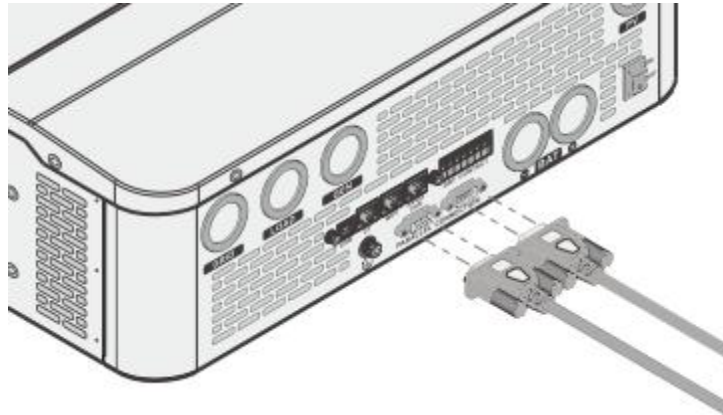

- See the diagram below for parallel connection

Set the item [31] to "PAL" and the item [68] to "0°." When setting the item [38] to "120 V," the output L-N voltage is 120 V

#### 1. Two parallel-connected solar storage inverters:

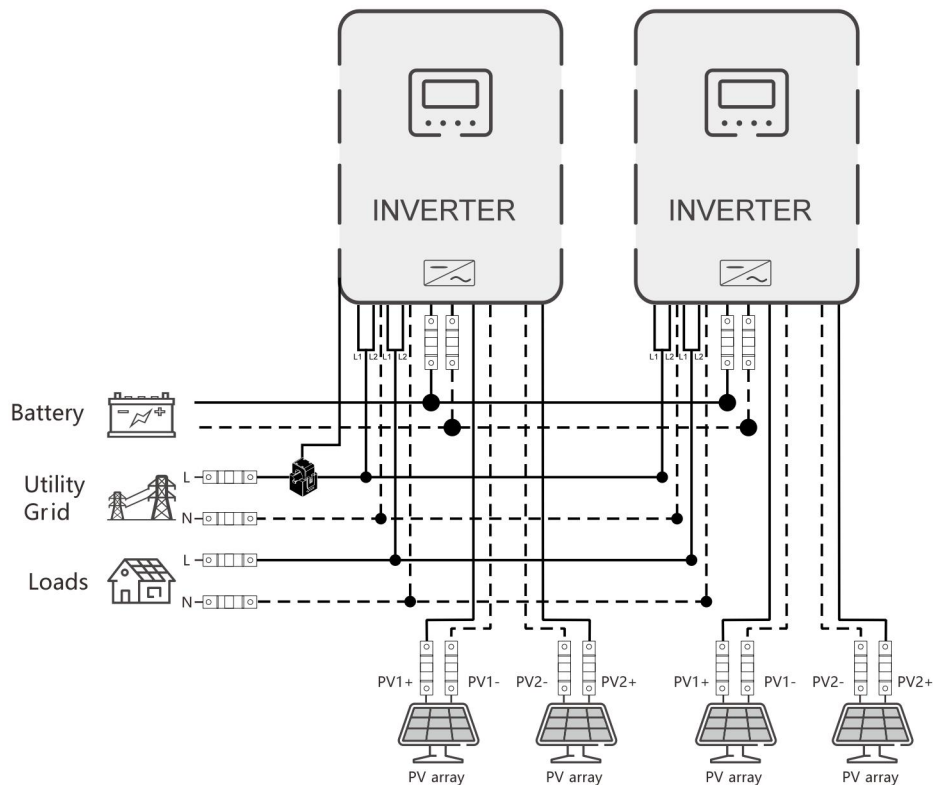

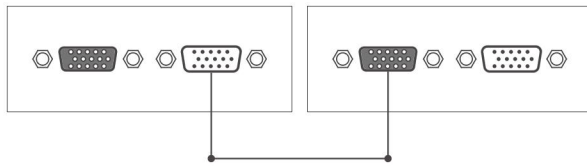

2. **Three parallel-connected solar storage inverters:**

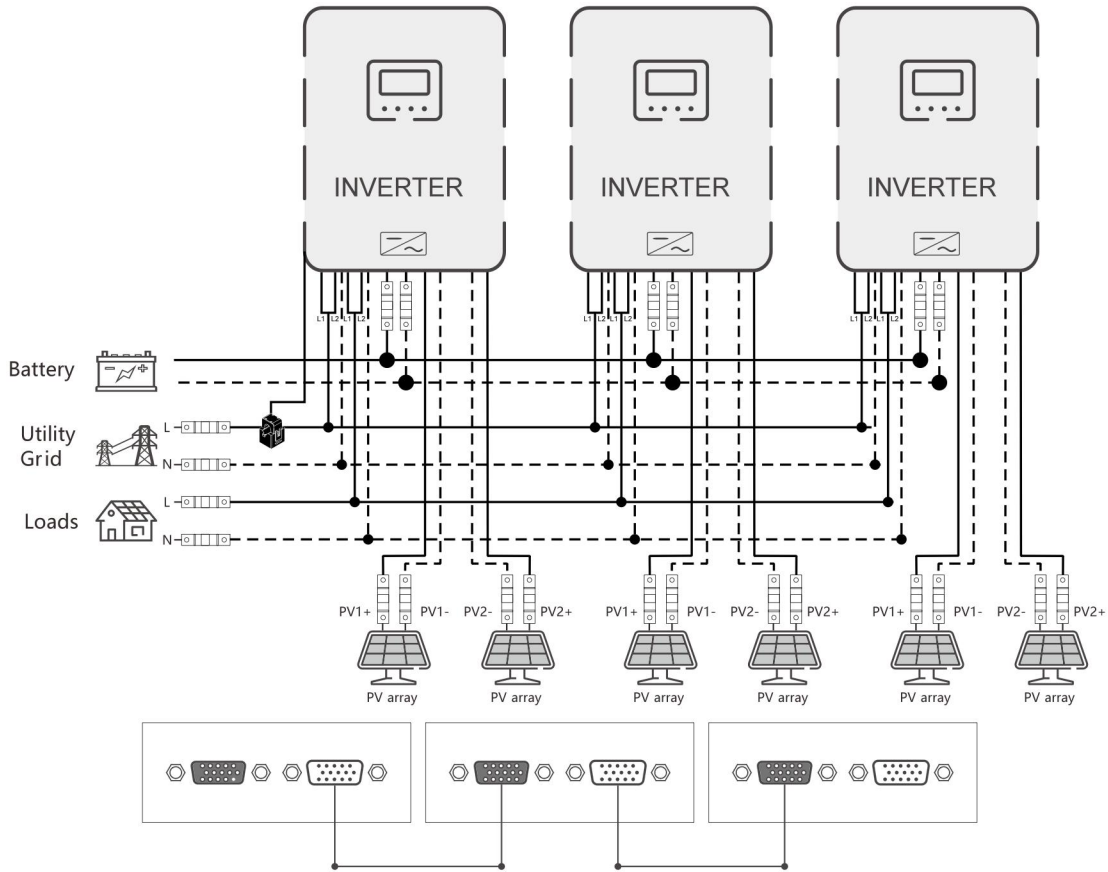

3. **Four parallel-connected solar storage inverters:**

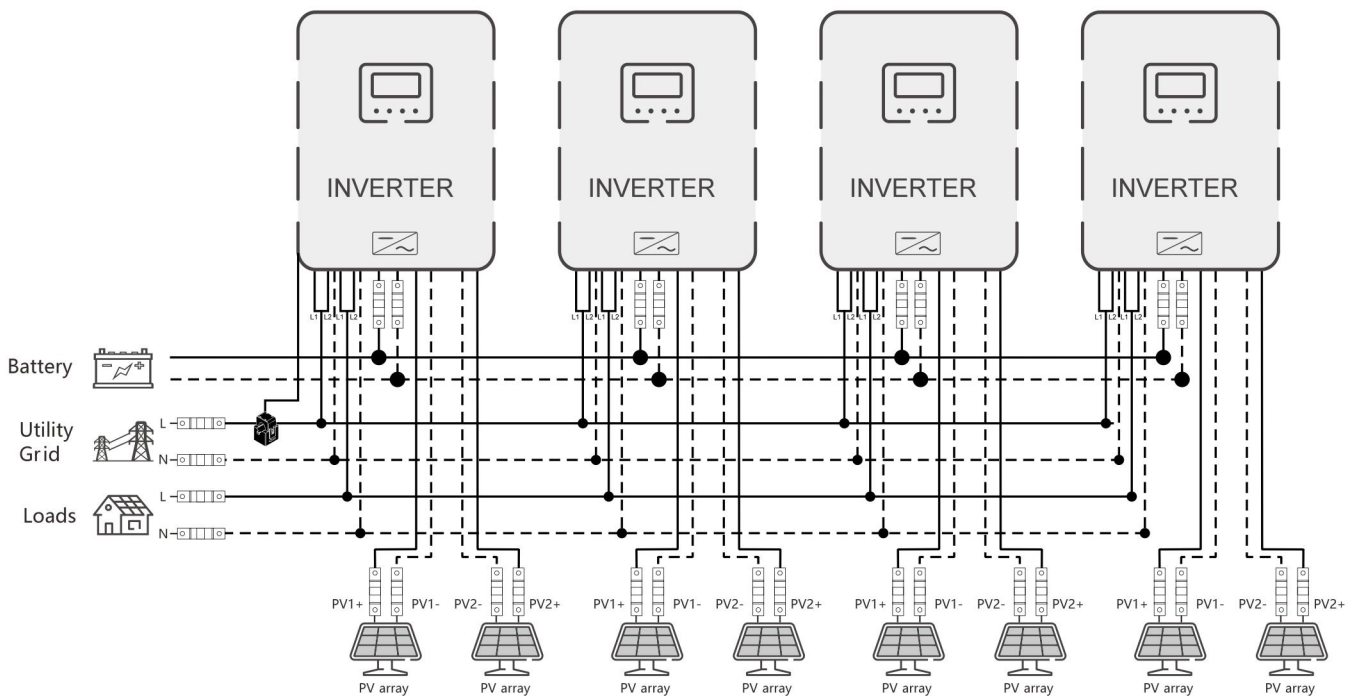

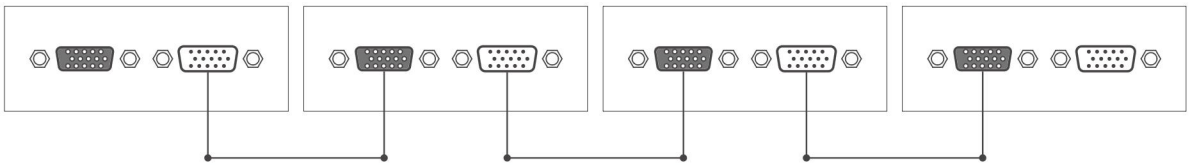

**4. Five parallel-connected solar storage inverters:**

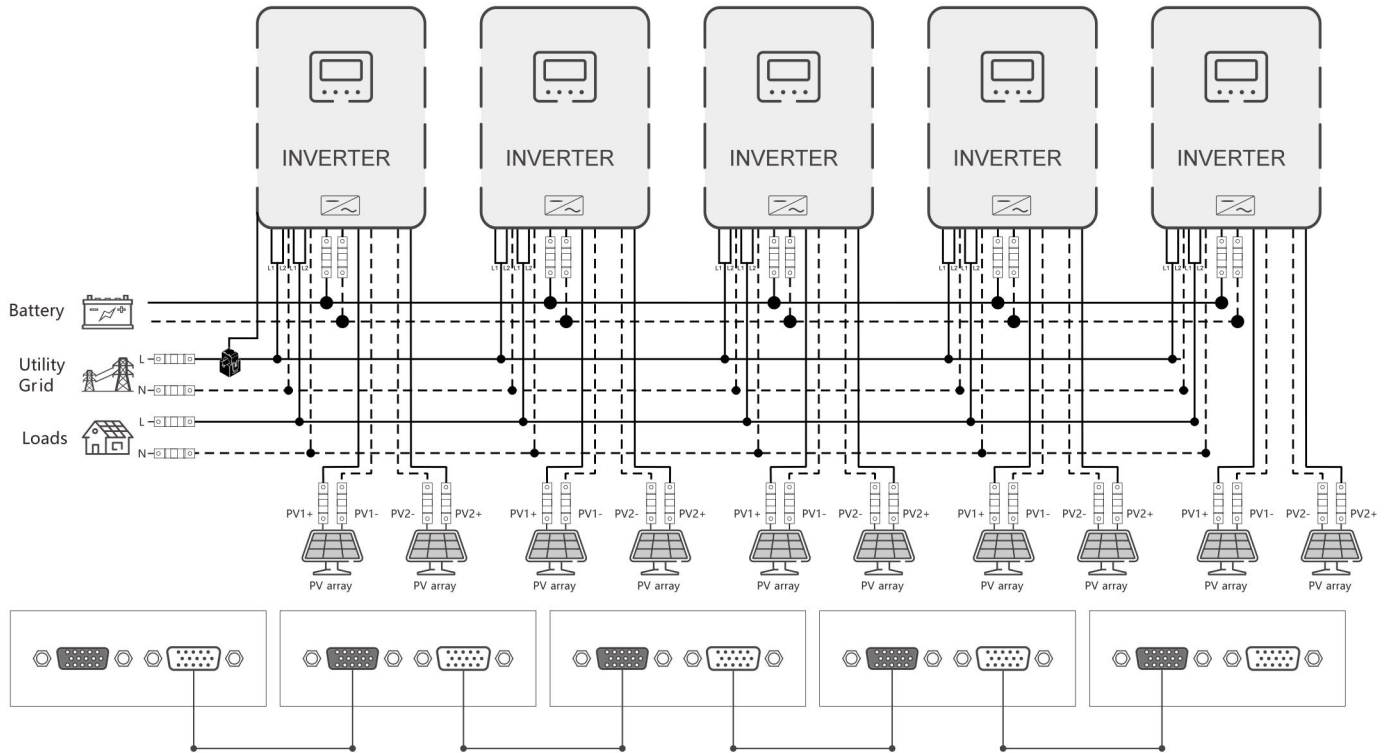

**5. Six parallel-connected solar storage inverters:**

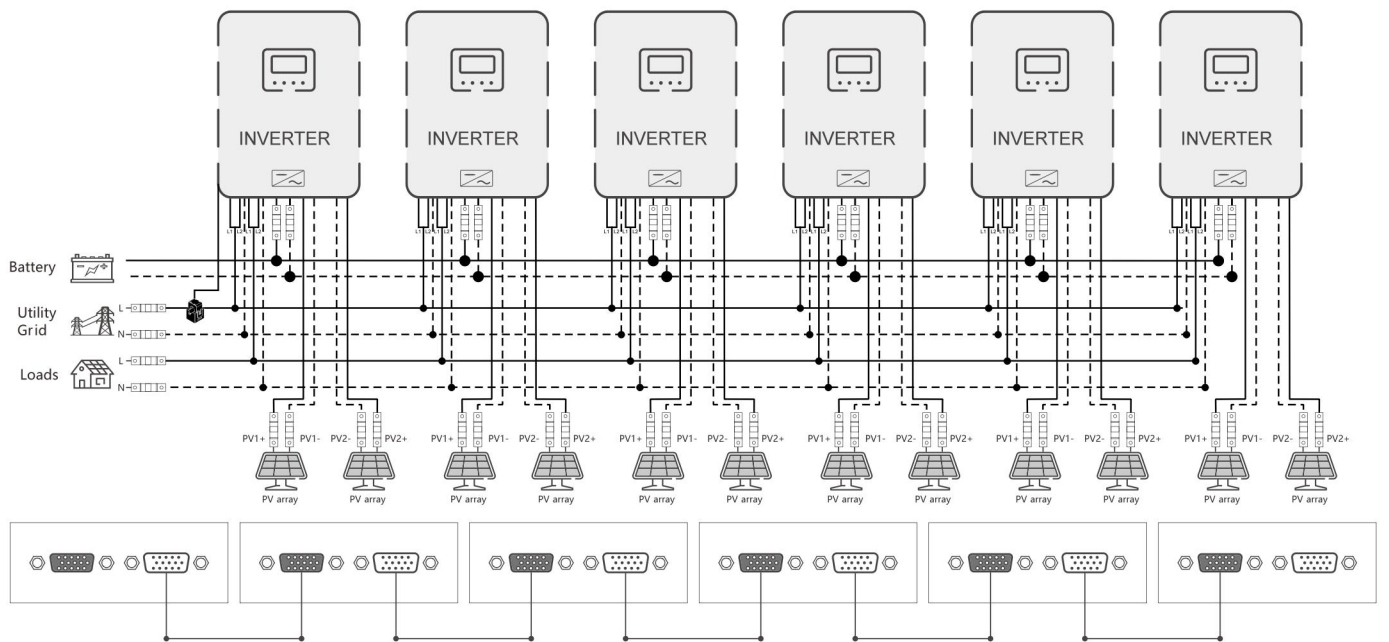

#### 4.9.4 Wiring diagram for two-phase parallel connection (phase difference between L1 and L2: 0°)

- (1) P1: Set the item [31] to "2P0;" P2: Set the item [31] to "2P1," all of the P1/P2 inverter item [68] can not be set, it is default "0°" and the phase difference between P1 and P2 is 120°. When setting the item [38] to "120 V," the voltage between the live wire L1 of P1 phase and the live wire L2 of P2 phase is 208 V, and the L1-N voltage is 120 V
- (2) P1: Set the item [31] to "2P0;" P2: Set the item [31] to "2P2," all of the P1/P2 inverter item [68] can not be set, it is default "0°" and the phase difference between P1 and P2 is 180°. When setting the item [38] to "120 V," the voltage between the live wire L1 of P1 phase and the live wire L2 of P2 phase is 240 V, and the L1-N voltage is 120 V, L2-N voltage is 120V

##### a. Split-phase system (two inverters)

1+1 system:

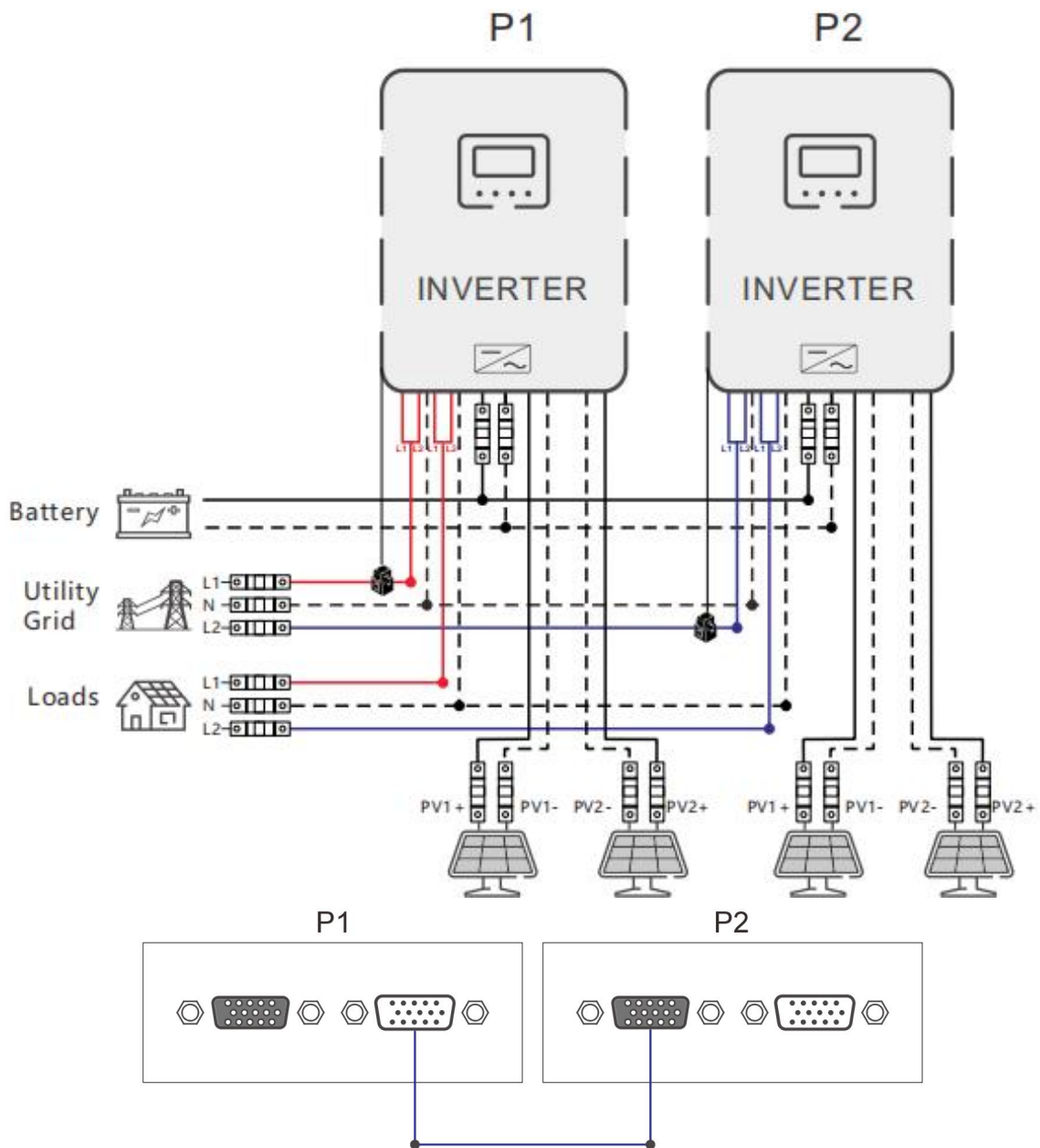

**b. Split-phase system (three inverters)**  
**2+1 system**

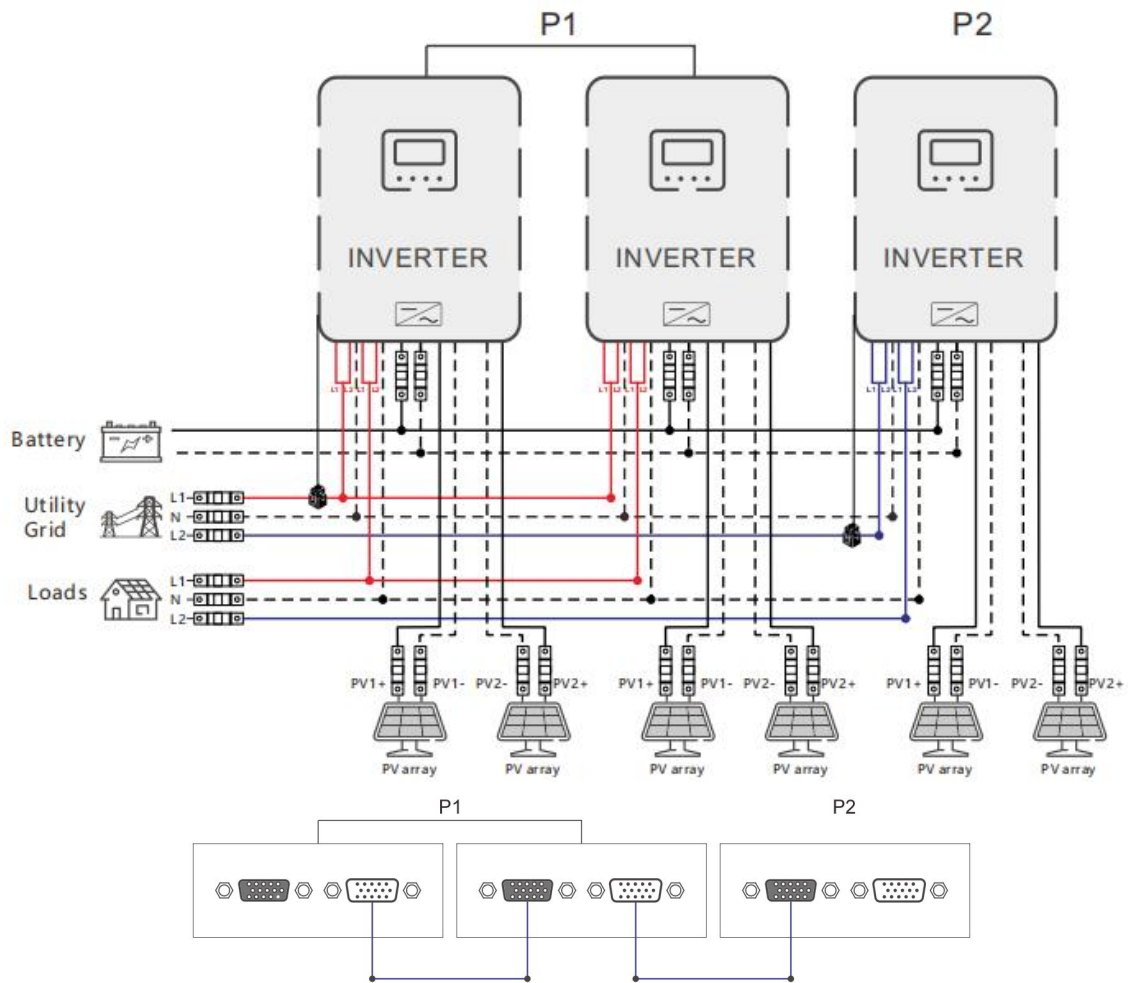

**c. Split-phase system (four inverters)**  
**3+1 system:**

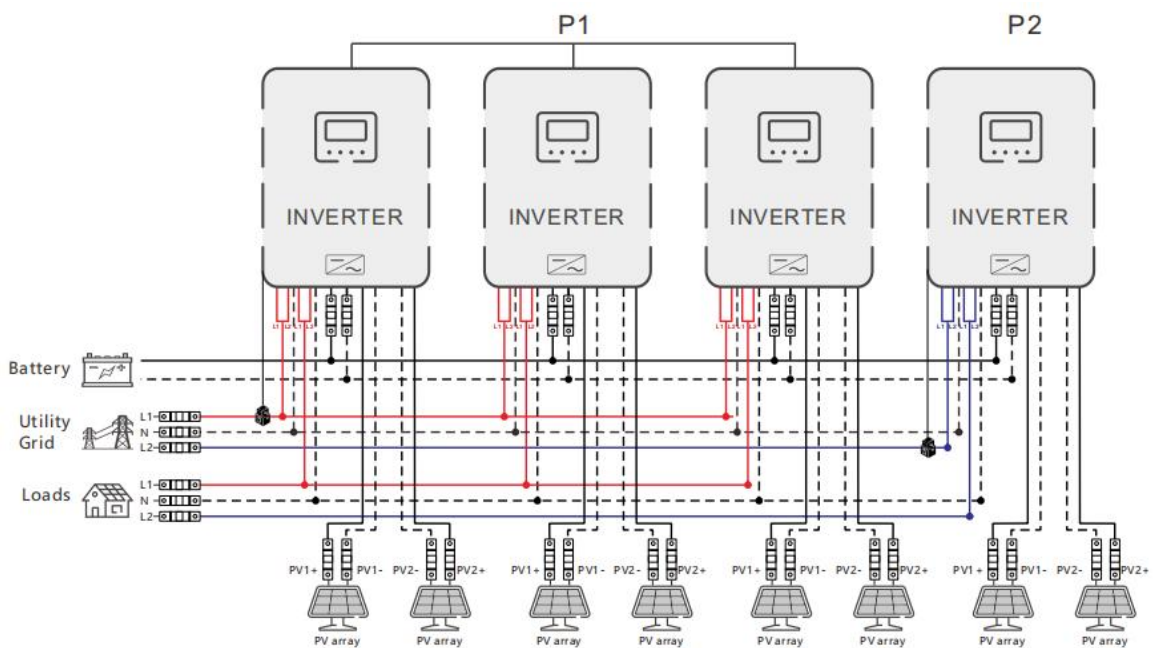

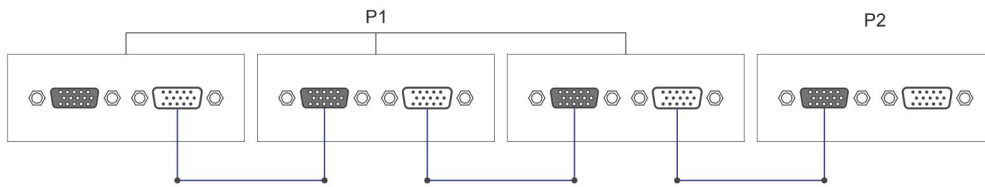

**2+2 system:**

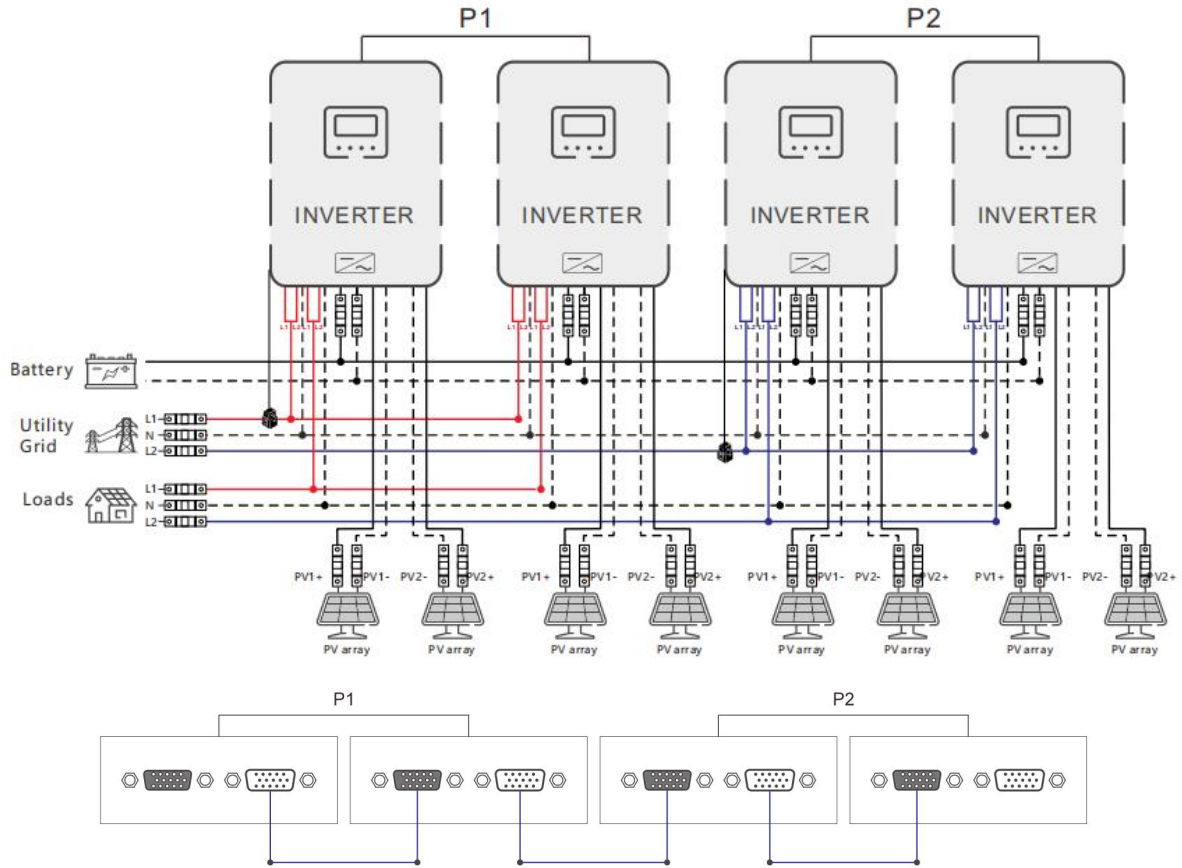

**d. Split-phase system (five inverters)**

**4+1 system:**

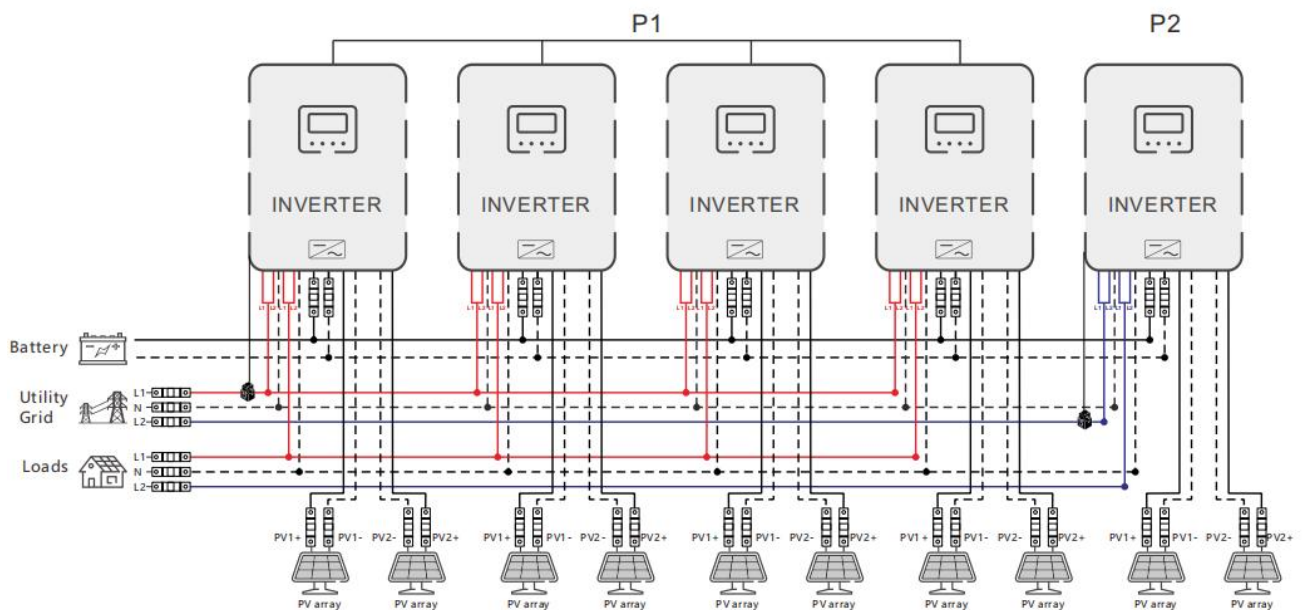

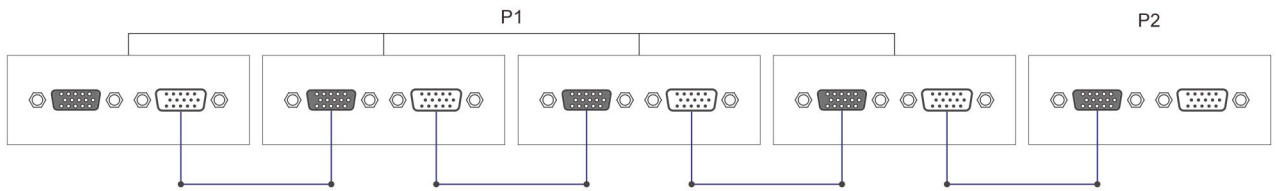

**3+2 system:**

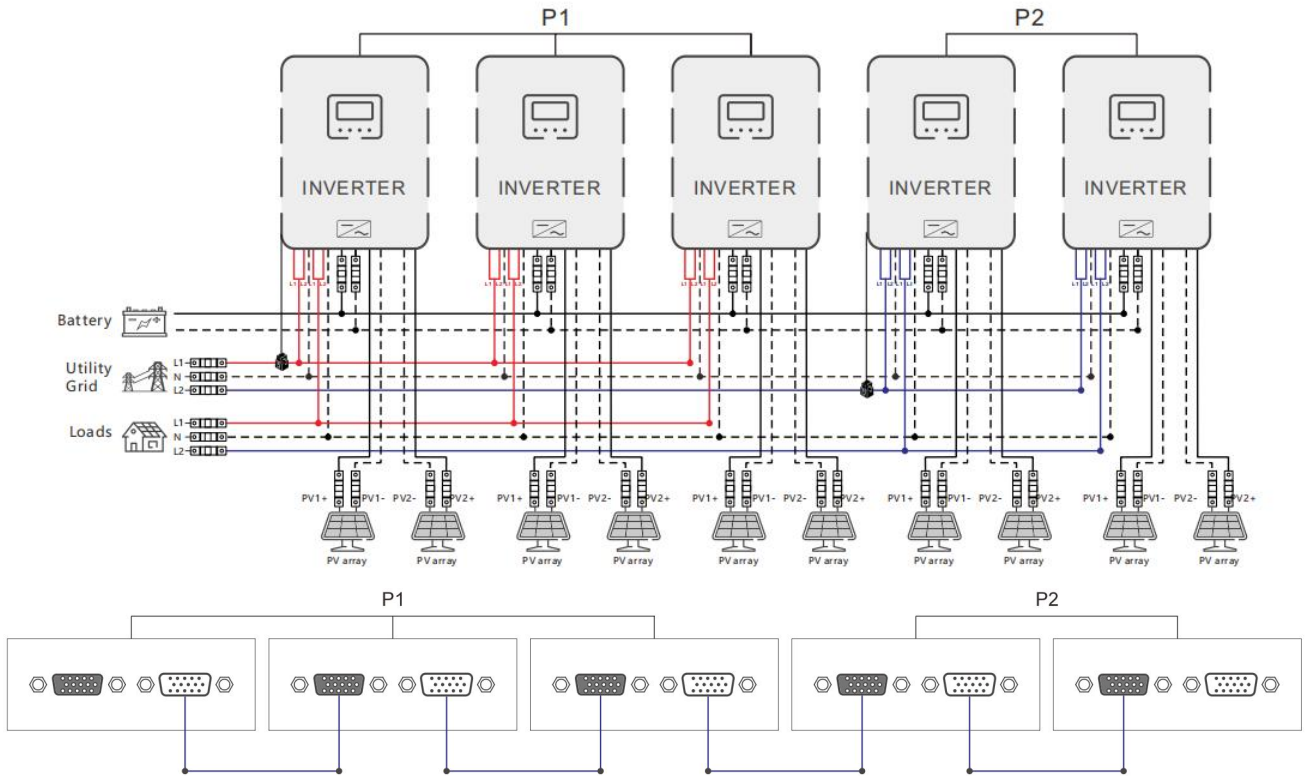

**e. Split-phase system (six inverters)**

**5+1 system:**

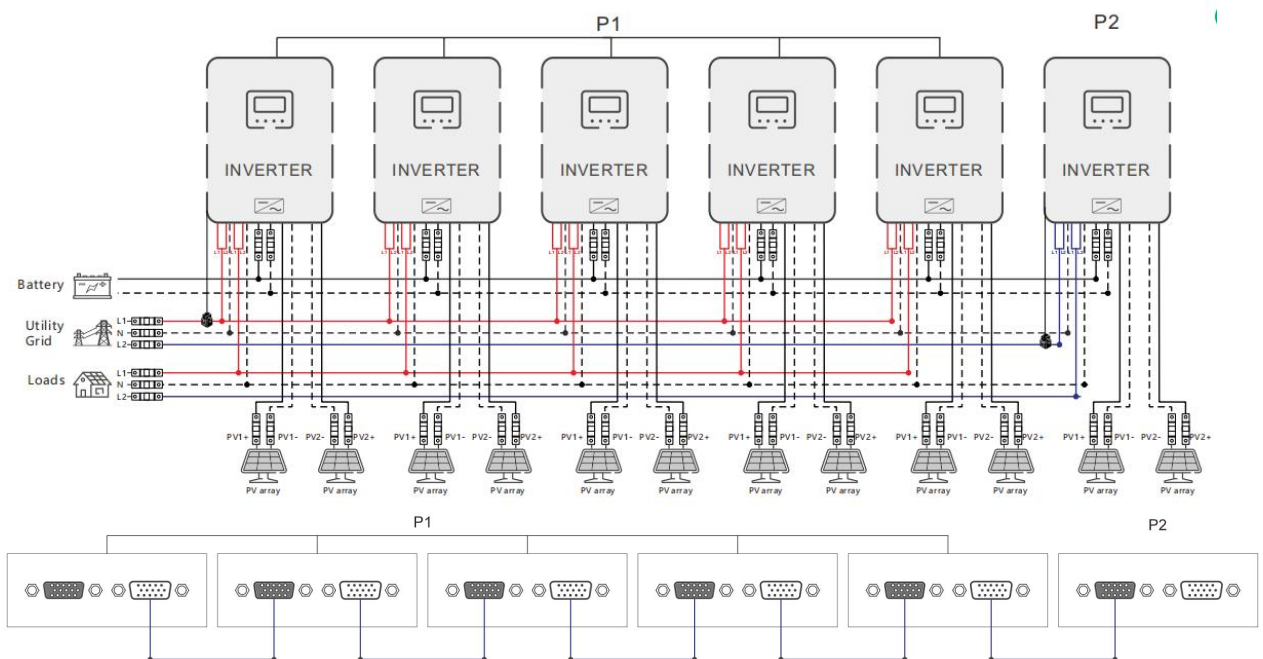

### 4+2 system:

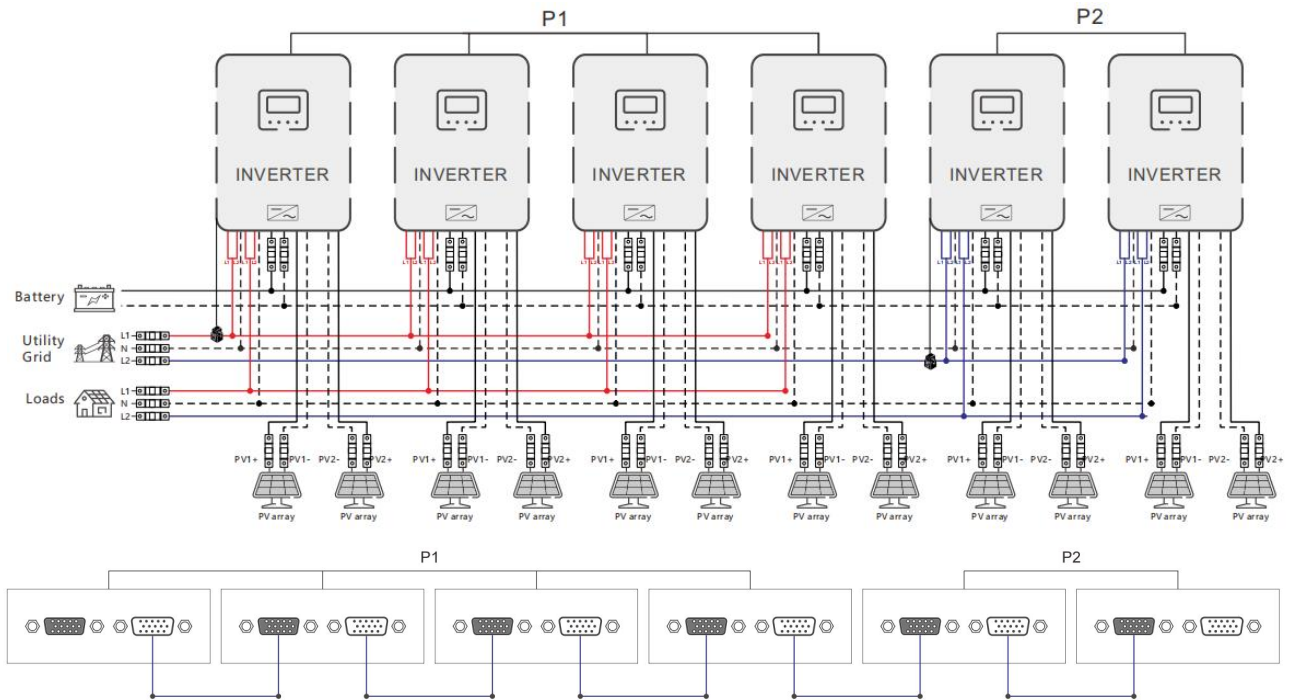

### 3+3 system:

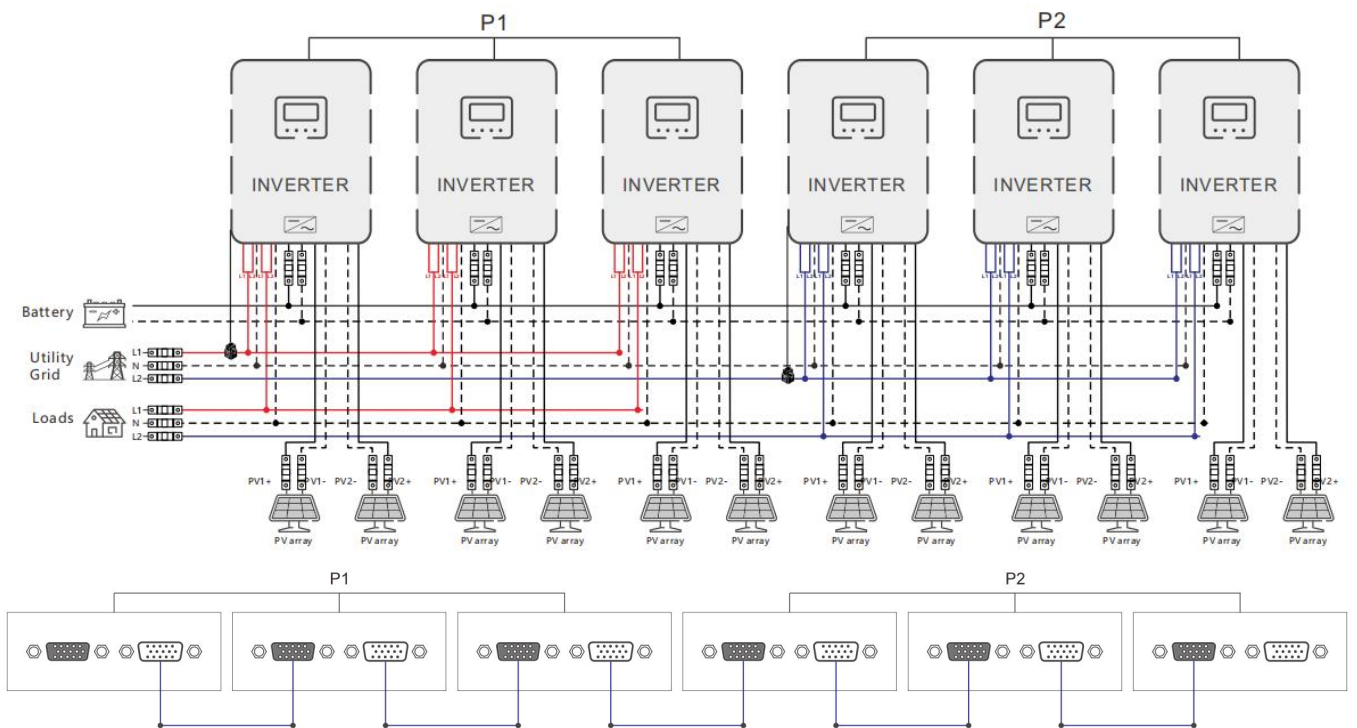



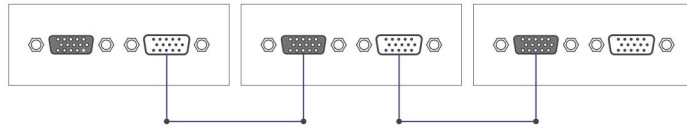

**c. Four parallel-connected solar storage inverters:**

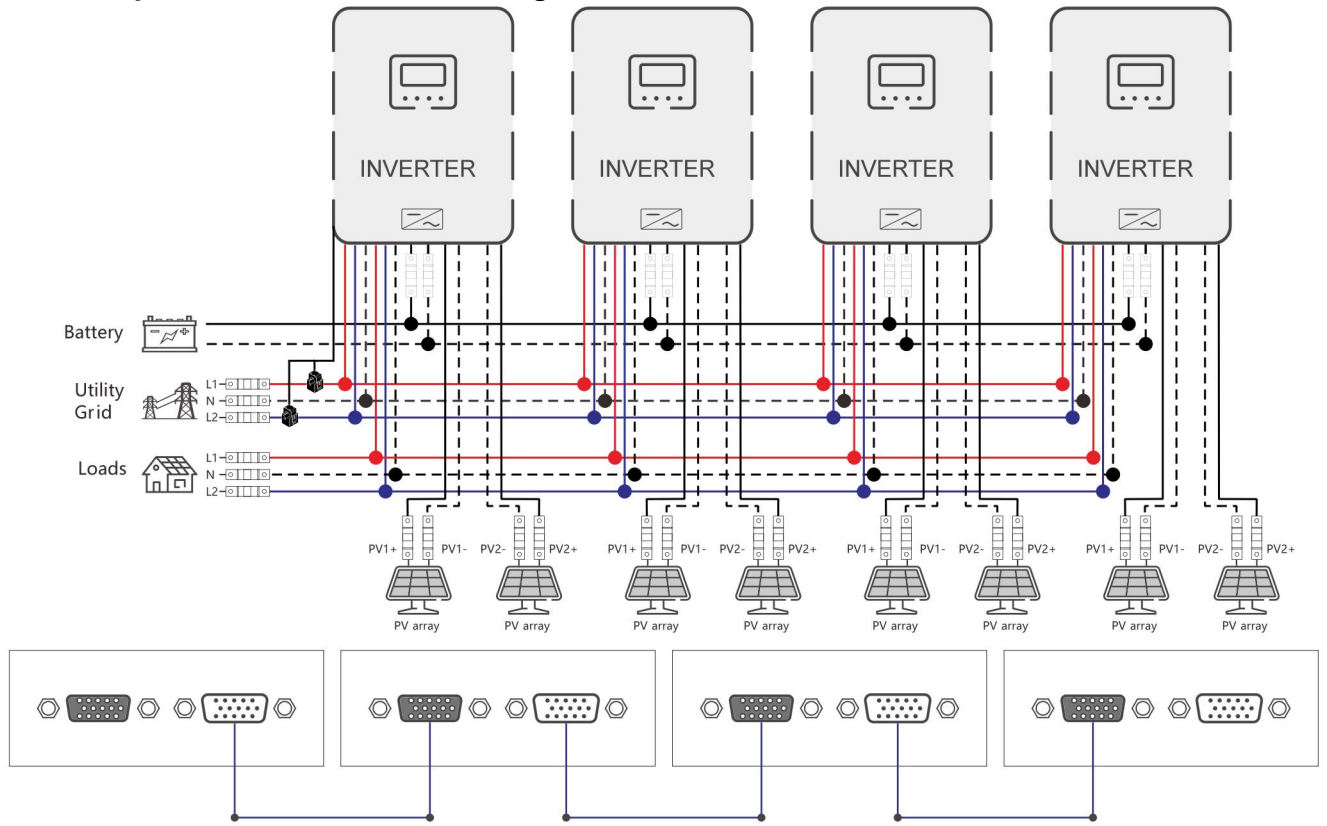

**d. Five parallel-connected solar storage inverters:**

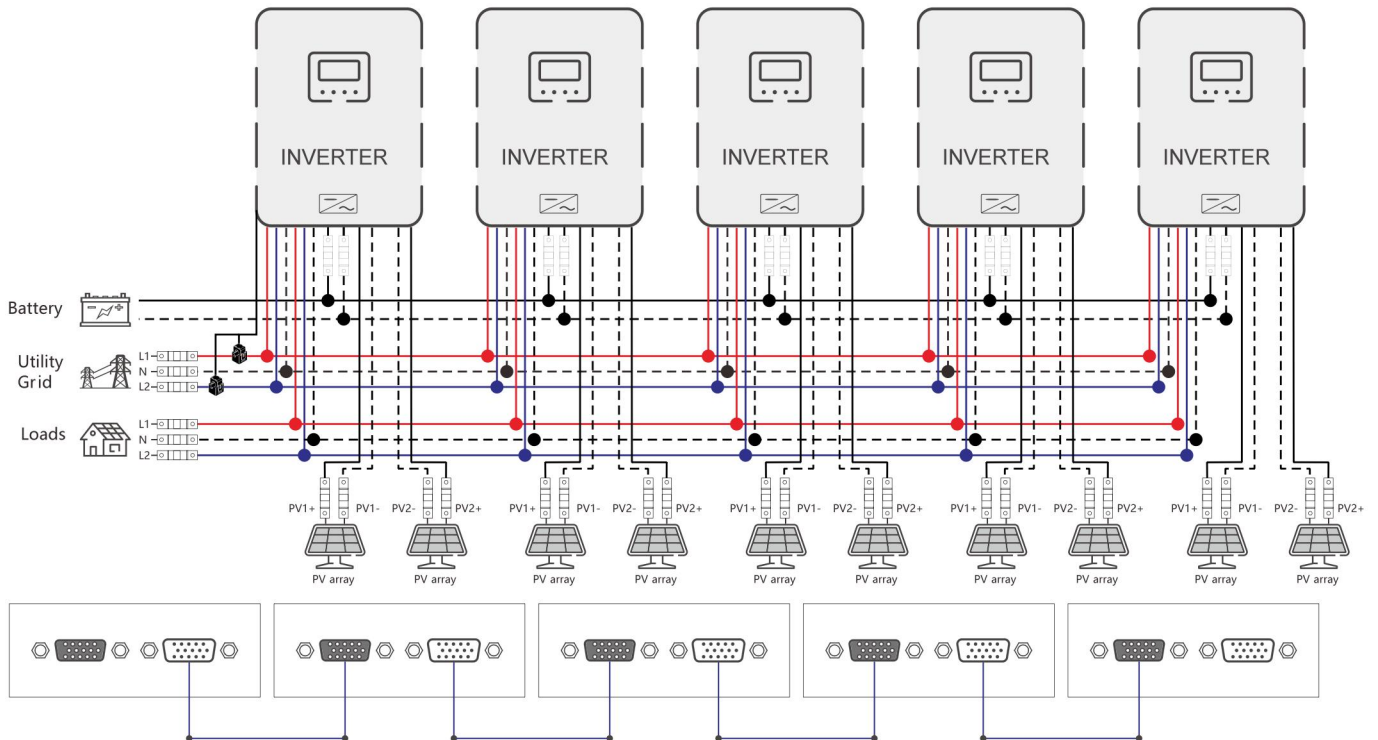

**e. Six parallel-connected solar storage inverters:**

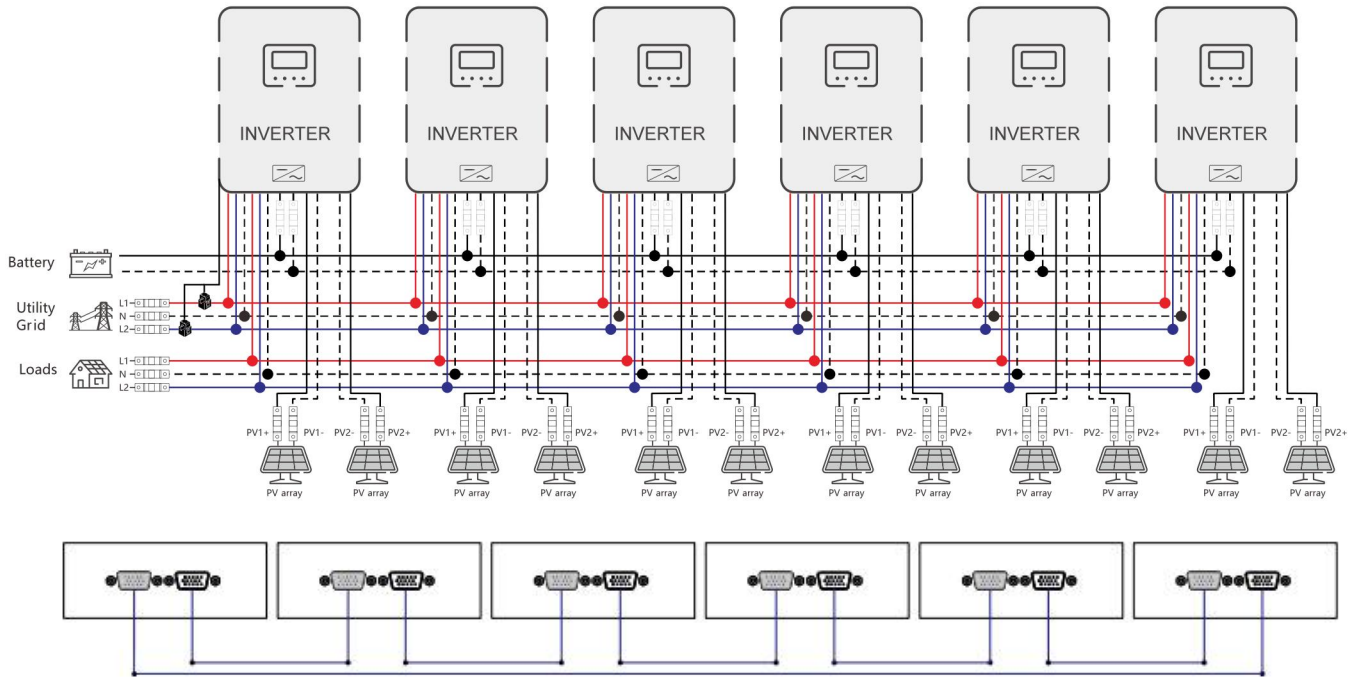

**4.9.6 Wiring diagram for three-phase parallel connection**

P1: Set the item [31] to "3P1;" P2: Set the item [31] to "3P2;" P3: Set the same to "3P3", all of P1/P2/P3 inverters item [68] can not be set, it is default "0"

At this point, the P1-P2, P1-P3, and P2-P3 phase difference is 120°. When setting the item [38] to "120 VAC," the voltage between the live wire L1 of P1 phase and the live wire L2 of P2 phase is  $120 \times 1.732 = 208$  VAC. Similarly, the L1-L3 and L2-L3 voltage is 208 VAC:

**a. Three-phase system (three inverters)**

**1+1+1 system:**

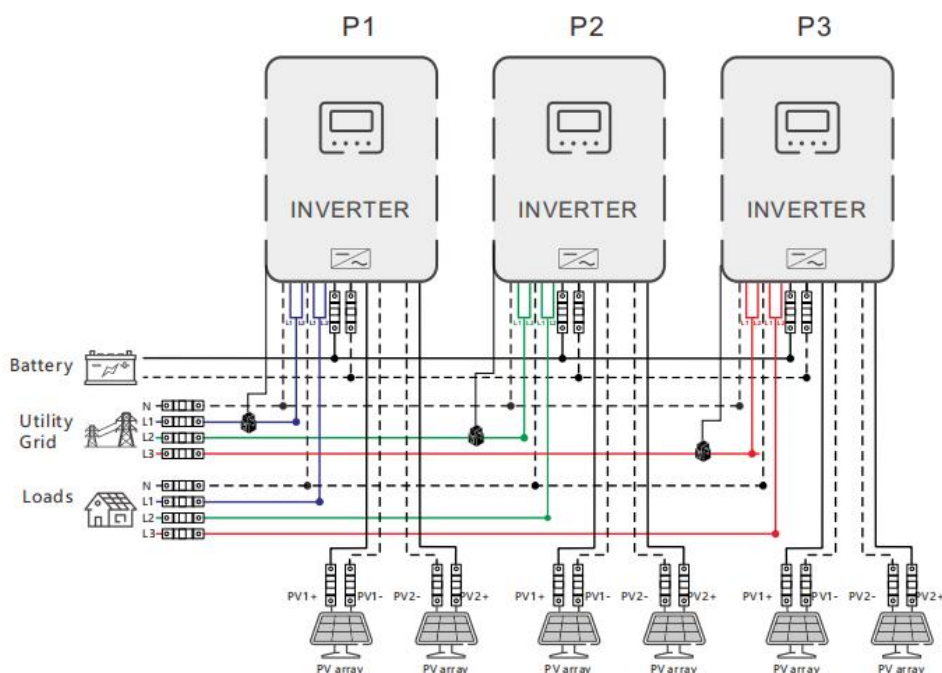

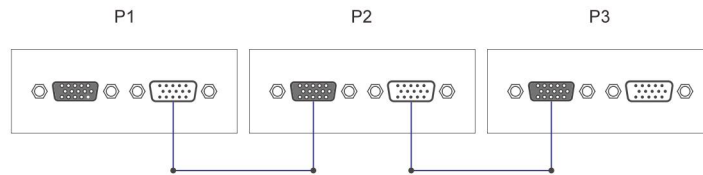

**b. Three-phase system (four inverters)**

**2+1+1 system:**

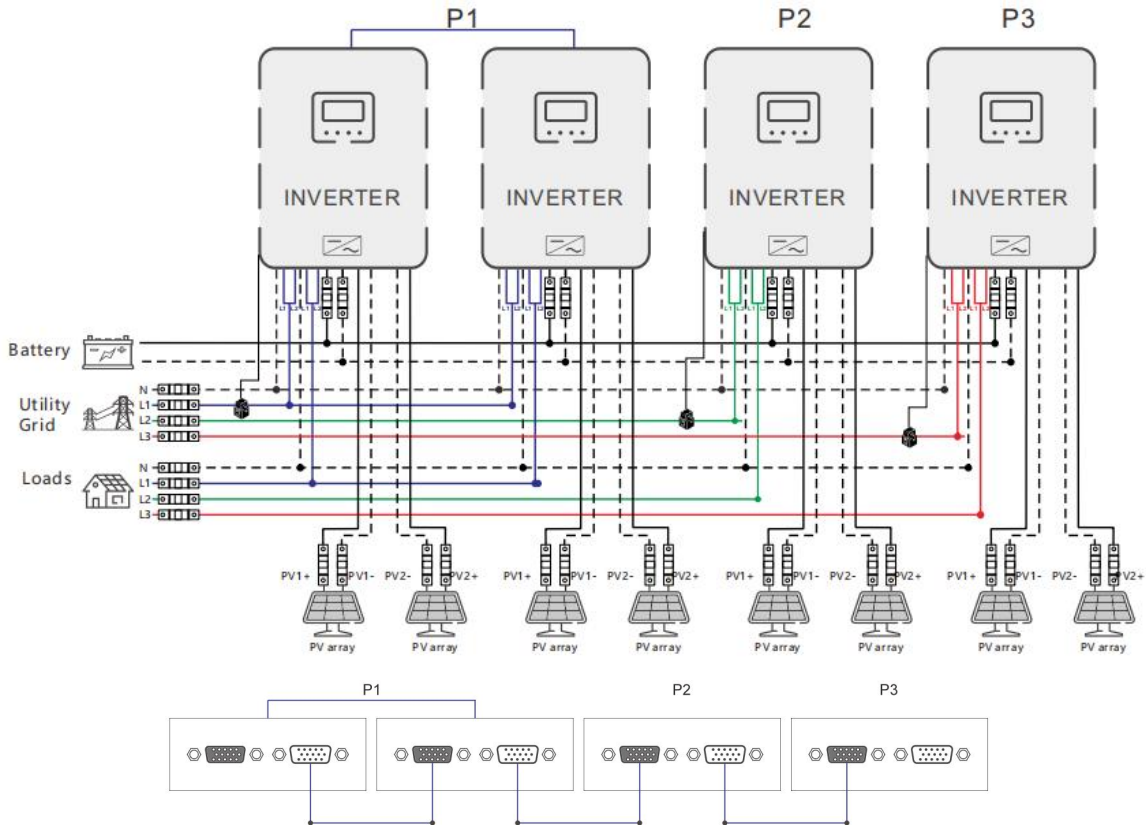

**c. Three-phase system (five inverters)**

**3+1+1 system:**

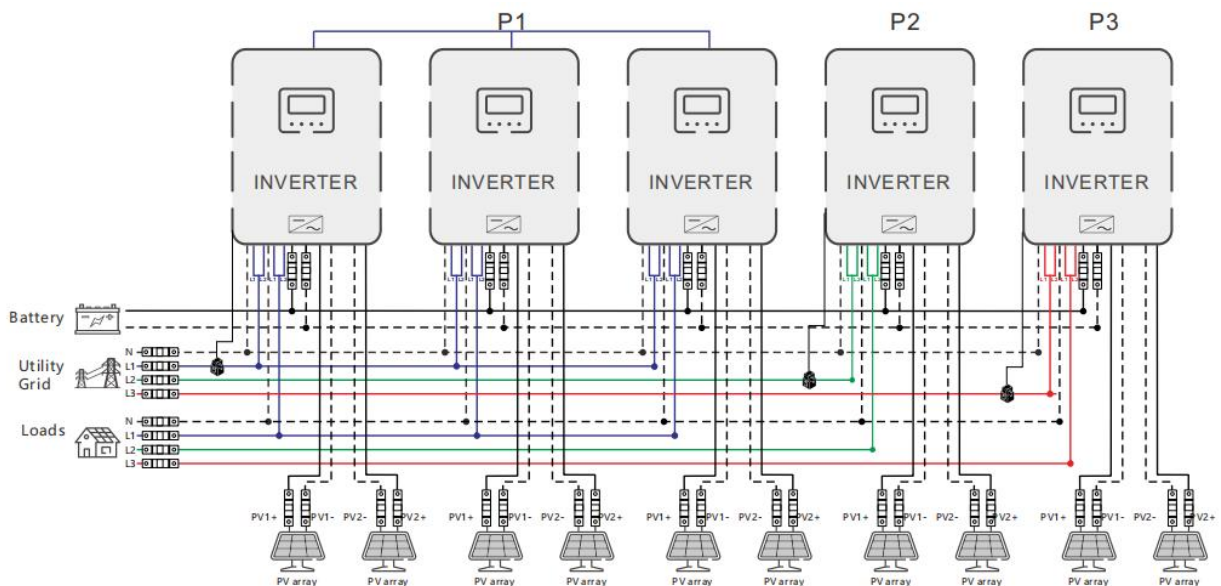

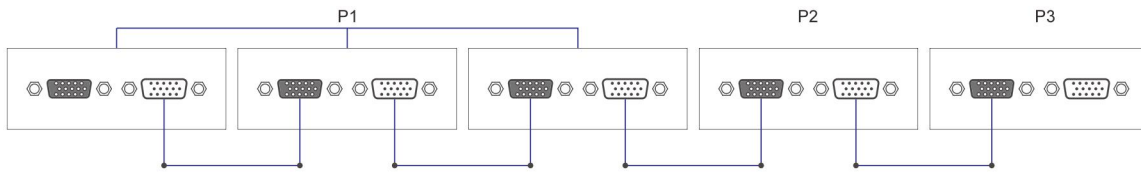

**2+2+1 system:**

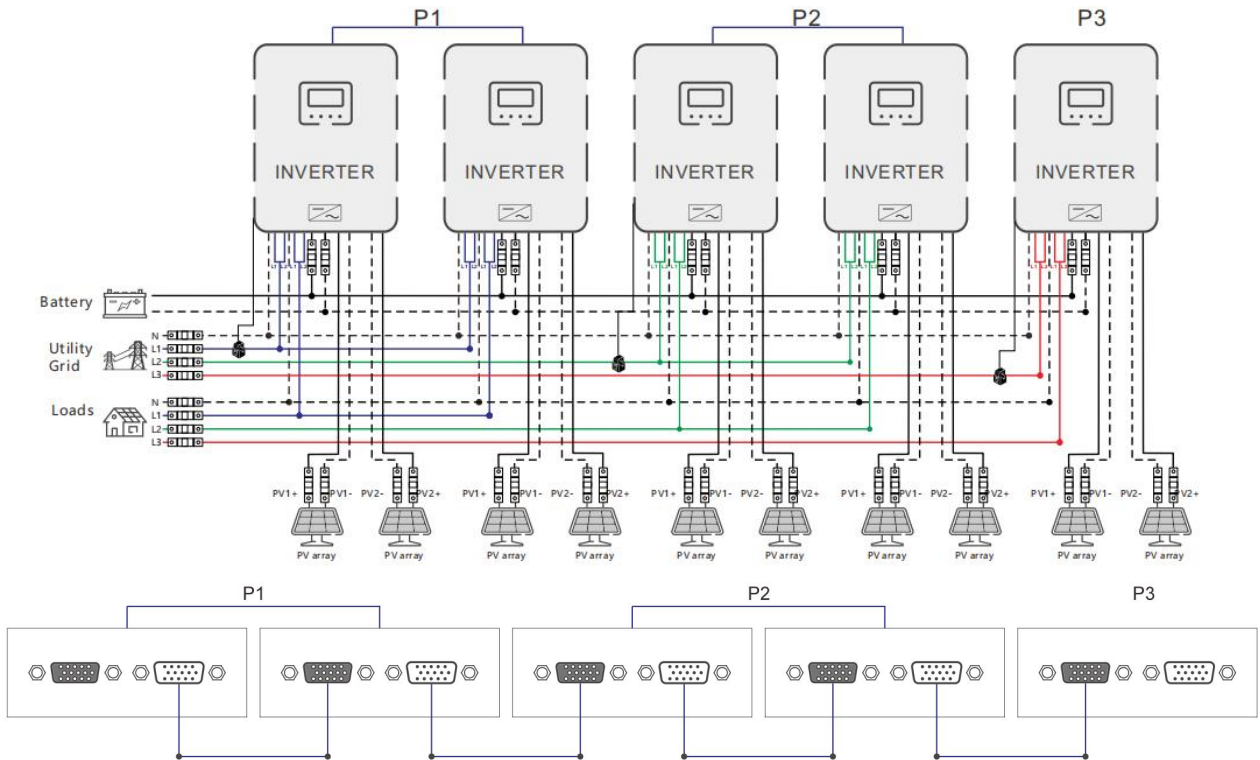

**d. Three-phase system (six inverters)**

**2+2+2 system:**

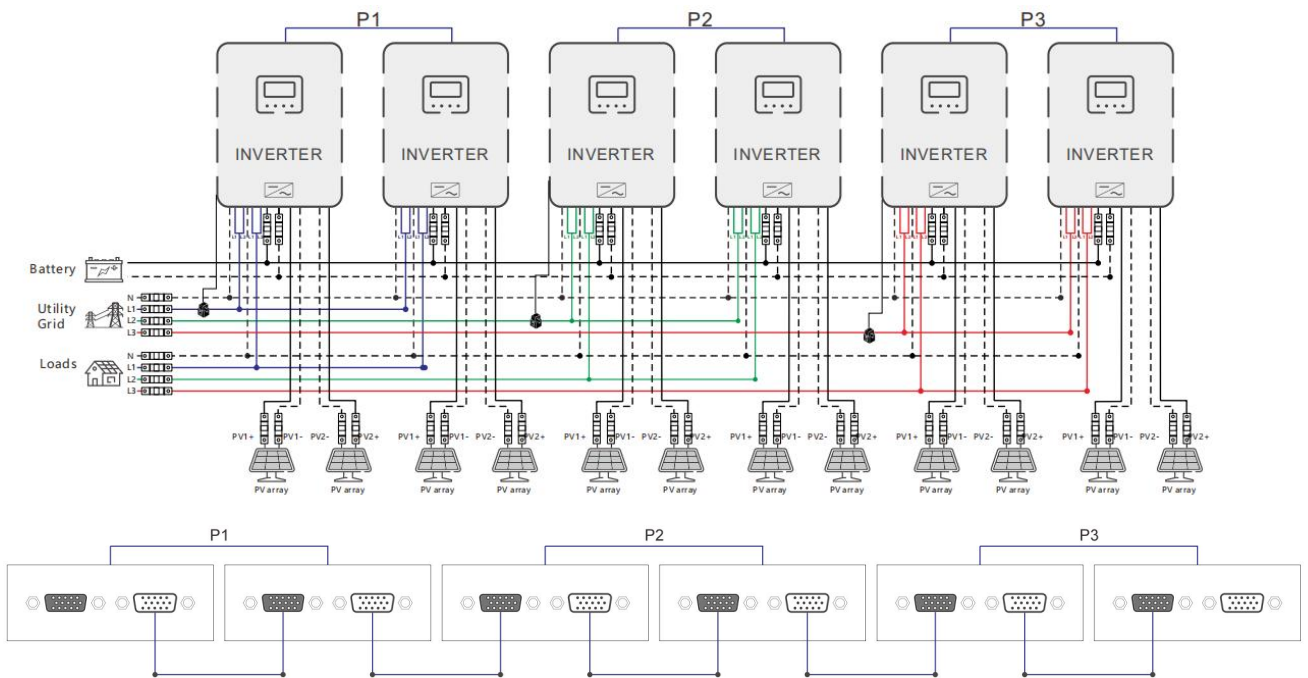

**3+2+1 system:**

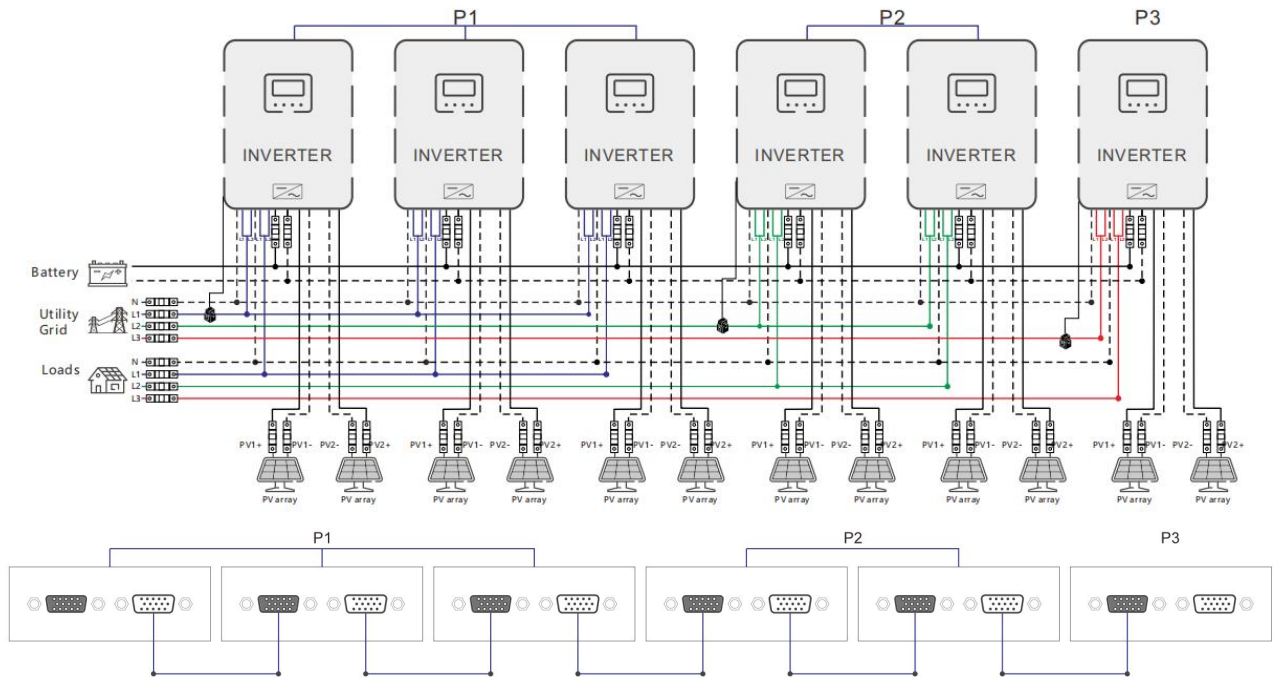

**4+1+1 system:**

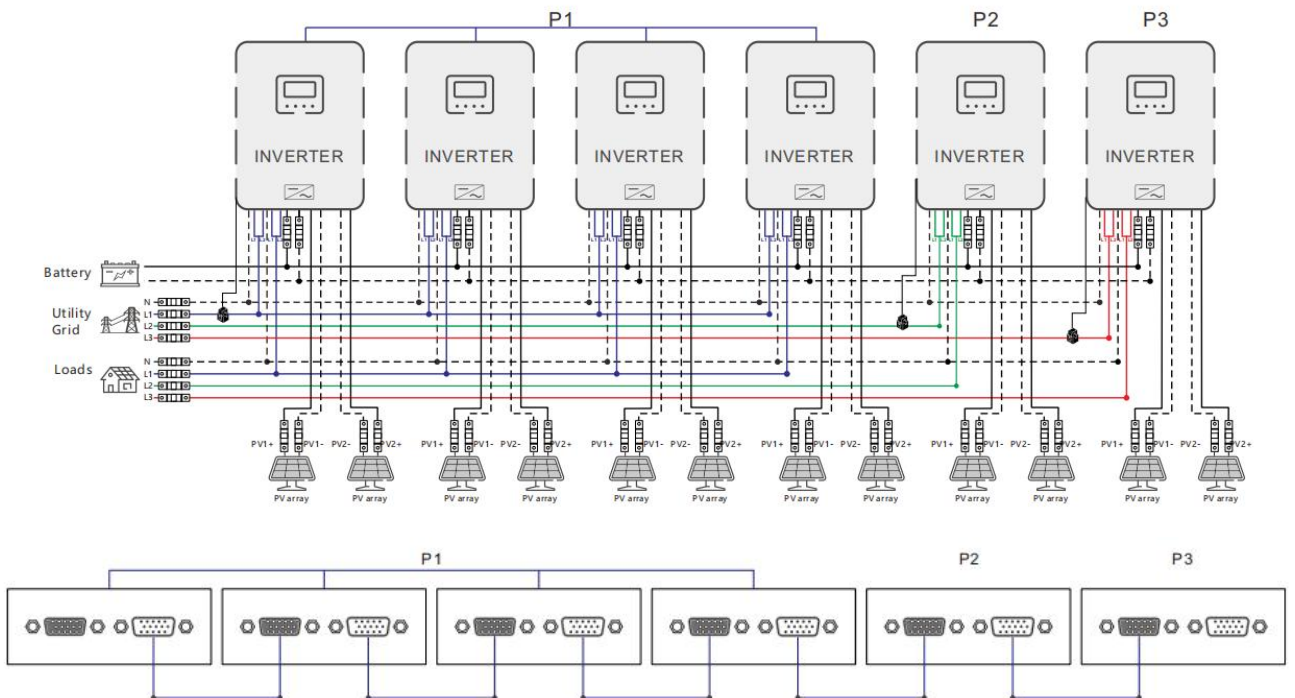

**Note:**

- 1) Before powering on and lighting up the screen, check for correct wiring according to the above wiring diagrams to avoid system problems.
- 2) Check all connections for firm fixing to avoid detachment and abnormal system operation.
- 3) When connecting the AC output to the load, complete wiring according to the requirements of the electrical load to avoid damage to the load.
- 4) Set the item [38] to the same parameter, or only set it in the host inverter. During parallel operation, the voltage set in the host shall prevail, so the host inverter will forcibly set the item to the value for slave inverters. Only in standby mode can the item be set.
- 5) The inverter defaults to single mode at the factory. If using the parallel or three-phase function, set the item [31] on the screen as follows:

Power on one inverter each time, turn off the other inverters, and then set the item [31] according to the on-site system operation mode. After setting the inverter, turn off the inverter, and set the other inverters one by one. After all are set, power on all inverters at one time to enter the working state.

**In single-phase parallel operation:**

Set the item [31] to "PAL" and the item [68] to "0°." When setting the item [38] to "120 V," the output L-N voltage is 120 V

**In two-phase parallel operation:**

(1) P1: Set the item [31] to "2P0;" P2: Set the item [31] to "2P1," all of P1/P2 inverters item [68] can not be set, it is default "0°" and the phase difference between P1 and P2 is 120°. When setting the item [38] to "120 V," the voltage between the live wire L1 of P1 phase and the live wire L2 of P2 phase is 208 V, and the L1-N voltage is 120 V

(2) P1: Set the item [31] to "2P0;" P2: Set the item [31] to "2P2," all of P1/P2 inverters item [68] can not be set, it is default "0°" and the phase difference between P1 and P2 is 180°. When setting the item [38] to "120 V," the voltage between the live wire L1 of P1 phase and the live wire L2 of P2 phase is 240 V, and the L1-N voltage is 120 V

**In split-phase parallel operation:**

Set the item [31] to PAL, and set the item [68] to 180°. When setting the item [38] to "120 V," the L1-L2 voltage is 240 V, and the L1-N voltage is 120 V

**In three-phase parallel operation:**

P1: Set the item [31] to "3P1;" P2: Set the item [31] to "3P2;" P3: Set the same to "3P3" all of P1/P2/P3 inverters item [68] can not be set, it is default "0°"

At this point, the P1-P2, P1-P3, and P2-P3 phase difference is 120°. When setting the item [38] to "120 VAC," the voltage between the live wire L1 of P1 phase and the live wire L2 of P2 phase is  $120 \times 1.732 = 208$  VAC. Similarly, the L1-L3 and L2-L3 voltage is 208 VAC:

- 6) After the system runs, measure the correct output voltage before connecting to loads.

# 5. Operation

## 5.1 Operation and display panel

The operation and display panel of the inverter includes one LCD screen, three indicators, and four physical buttons

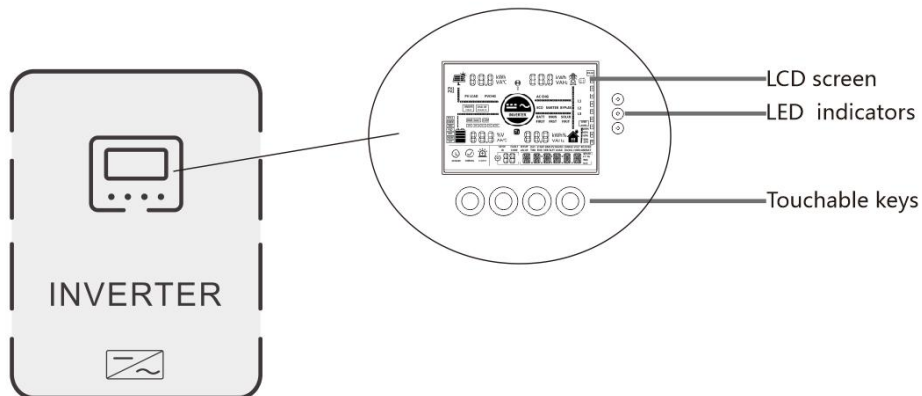

- Physical button**

Physical button	Description
	Enter/Exit the setup menu
	Go to the next option
	Go to the previous option
	Confirm/Enter the option in setup menu



- LED indicator**

Indicator	Color	Description
AC/INV	Green	Normally ON: mains bypass output
		Flash: inverter output
CHARGE	Yellow	Normally ON: charging completed
		Flash: charging
FAULT	Red	Normally ON: level-1 fault
		Flash: level-2 fault
		OFF: level-3 or level-4 fault

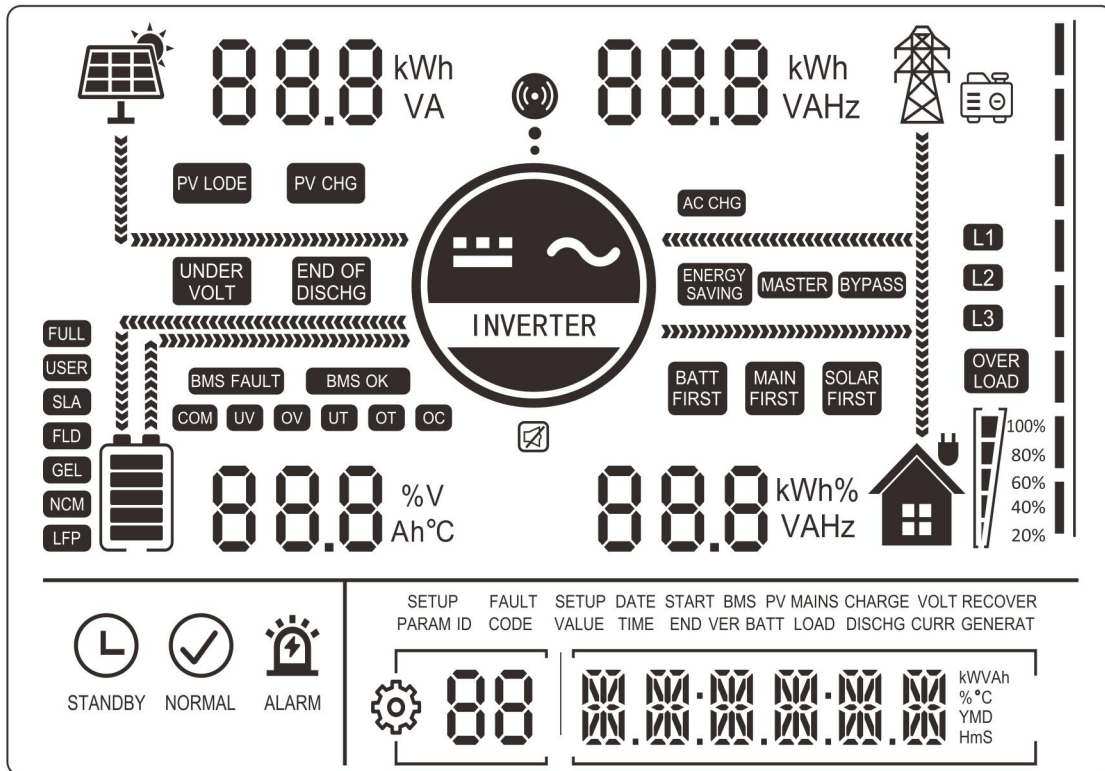
- Display screen



Icon	Description	Icon	Description
	PV panel		Mains
	Battery		Generator
	The inverter is working		Load
	The inverter is communicating with the data collector		The buzzer is in mute mode
	Power flow direction		
	The inverter is in standby mode		The inverter is working normally
	There is a fault		Settings
	Load power: 80%–100%		SOC: 80%–100%
	Load power: 60%–79%		SOC: 60%–79%
	Load power: 40%–59%		SOC: 40%–59%
	Load power: 20%–39%		SOC: 20%–39%

Icon	Description	Icon	Description
	Load power: 5%–19%		SOC: 5%–19%
<b>UNDER VOLT</b>	Battery under-voltage	<b>END OF DISCHG</b>	Battery over-discharge
<b>OVER LOAD</b>	Overload	<b>BMS FAULT</b>	BMS fault
<b>COM</b>	System communication error	<b>UV</b>	System under-voltage
<b>OV</b>	System overvoltage	<b>UT</b>	Too low system temperature
<b>OT</b>	Too high system temperature	<b>OC</b>	System overcurrent
<b>FULL</b>	Battery full power	<b>USER</b>	User-defined battery
<b>SLD</b>	Sealed lead-acid battery	<b>FLD</b>	Flooded lead-acid battery
<b>GEL</b>	Gel lead-acid battery	<b>NCM</b>	Ternary Li-ion battery
<b>LFP</b>	LFP Li-ion battery	<b>ECO</b>	Energy-saving mode
<b>PVLOAD</b>	PV power is loading	<b>PVCHG</b>	PV power is charging the battery
<b>ACCHG</b>	AC input power is charging the battery	<b>MAINS FIRST</b>	The output mode of the inverter is mains first
<b>BYPASS</b>	The output mode of the inverter is mains bypass	<b>SOLAR FIRST</b>	The output mode of the inverter is PV first
<b>BATT FIRST</b>	The output mode of the inverter is battery first		

- **Real-time parameters view**

On the screen, press the UP/DOWN button to view real-time data of the inverter in operation

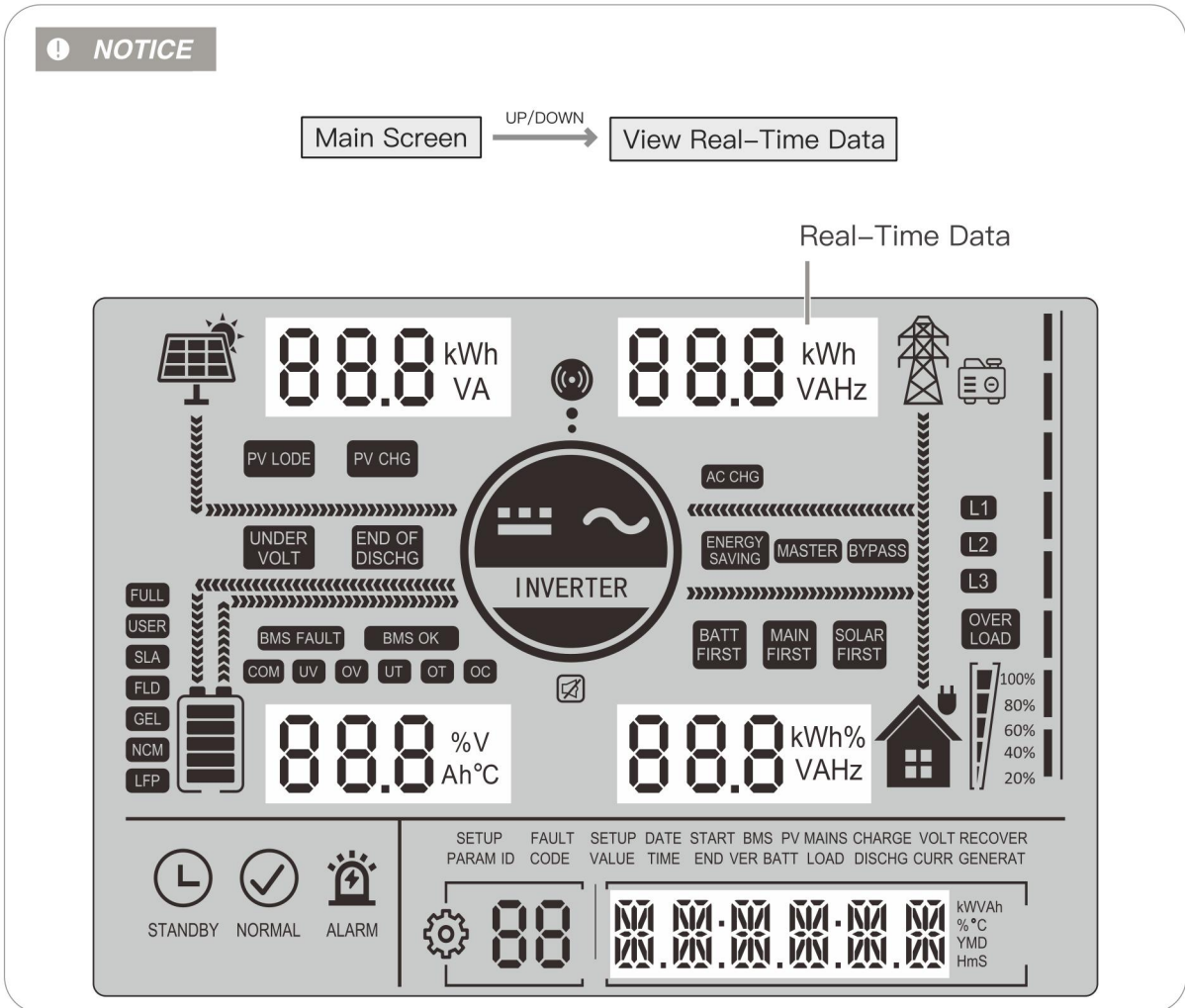

<b>Page</b>	<b>PV</b>	<b>Battery</b>	<b>AC input</b>	<b>Load</b>	<b>General</b>
1	PV input voltage	Battery voltage	Mains input voltage	Single-phase voltage	Current time
2	PV input current	Battery current	Mains input current	Single-phase current	Current date
3	PV input power	Battery voltage	Mains total input power	Single-phase active power	PV gross generation
4	PV generation for the day	Battery current	Mains charging capacity for the day	Single-phase apparent power	Total load consumption
5	PV heat sink temperature	Heat sink temperature	Mains frequency	Inverter output frequency	RS485 address
6	Rated open circuit voltage	Rated battery voltage	Bus voltage	Rated output frequency	Software version
7	Maximum PV charge current	Maximum battery charge current	Maximum mains charge current	Total output active power	/
8			/	Total output apparent frequency	/

# 5.2 Setting

**NOTICE**

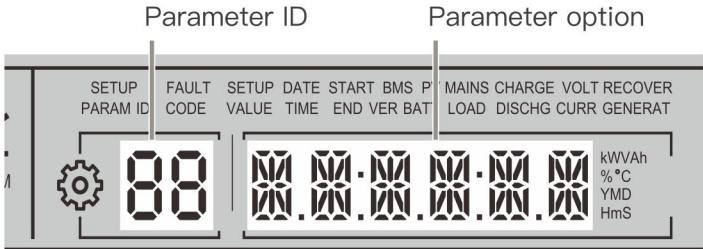
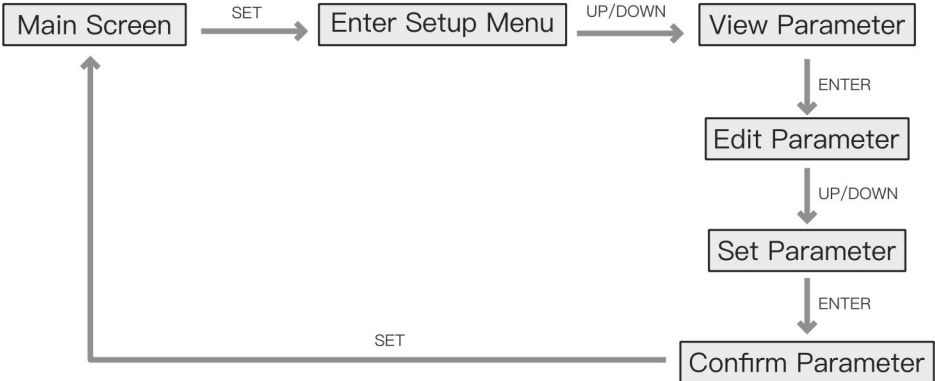

ID	Parameter	Option	Description
The voltage setting logic: 【15】 < 【12】 < 【04】 < 【14】 < 【35】 < 【37】 < 【05】 < 【09/11】 (When the battery communicate with inverter, the voltage setting is useless )			
00	Exit	ESC	Exit the setup menu
01	AC output mode	UTI (default)	Photovoltaic energy priority with the load, photovoltaic is not enough, the grid power and photovoltaic mixed load, photovoltaic energy is enough with the load, the excess energy to charge the battery, the grid power only starts charging when the battery is too discharged (06 Settings as" OSO(only PV ) ) ", the grid power will not charge), the battery is only discharged when off the grid
		SBU	Inverter first. The PV mode is to be applied first for loading, and only when the battery voltage is lower than the set value in the item 4, it will switch to the mains mode for loading. When the battery voltage is higher than the set value in the item 5, it will switch back to the PV mode from the mains mode.
		SOL	The PV mode is to be applied first and when the PV power is unavailable or the battery voltage is lower than the set value in the item 4, it will switch to the mains mode
		SUB	Solar energy priority charging, insufficient solar energy, grid energy and solar energy hybrid charging (if 06 Settings as" OSO(only PV )",the grid energy will not charge) and grid with load, when solar energy is enough to charge,excess energy not enough to load, excess solar energy and grid will hybrid load, the battery is discharged only when off the grid
02	AC input frequency	50.0	In bypass mode, the AC output frequency will adapt to the mains frequency, and in other cases, the output will follow the preset value.
		60.0 (default)	
03	AC input voltage range	UPS (default)	When the output voltage is 120/110 V, the input voltage range is 90 V–140 V
		APL	When the output voltage is 100/105 V, the input voltage range is 85 V–140 V
04	Battery to mains voltage threshold	43.6 (default)	When the parameter item 01 is SBU or SOL and the battery voltage is lower than the threshold, the output switches from inverter to mains. Setting range: 40 V–52 V
05	Mains to battery voltage threshold	57.6 (default)	When the parameter item 01 is SBU or SOL and the battery voltage is higher than the threshold, the output switches from mains to inverter. Setting range: 48 V–60 V
06	Battery charge mode	SNU (default)	When both PV power and mains are used to charge the battery at one time, the PV charge first and when the PV power is insufficient, the mains tags in. Only in bypass mode can both PV power and mains be used to charge the battery at one time, and

ID	Parameter	Option	Description
			only the PV charge mode can be enabled during inverter operation.
		OSO	Do not enable the mains charge mode when in only PV charge mode
07	Battery charge current	60A	SPI-4K-UP setting range:0-100A
			SPI-5K-UP setting range:0-120A
			SPI-6K-UP setting range:0-140A
			SPI-6.5K-UP setting range:0-140A
08	Battery type	USER	User-defined, and in this type, you can set all battery parameters
		SLD	Sealed lead-acid battery
		FLD	Flooded lead-acid battery
		GEL (default)	Gel lead-acid battery
		L14/L15/L16	LFP battery L14/L15/L16, corresponding to 14, 15, and 16 series of LFP batteries
		N13/N14	Ternary Li-ion battery N13/N14, corresponding to 13 and 14 series of ternary Li-ion batteries
		NOb	No battery
09	Battery boost charge voltage	56.8	Setting range: 48 V–58.4 V, with a step of 0.4 V, available for user-defined and lithium-ion battery types
10	Boost charge duration	120	The continuous charging time when the voltage reaches the set voltage during constant voltage charging, with a setting range of 5 min–900 min and a step of 5 min
11	Battery floating charge voltage	55.2	Setting range: 48 V–58.4 V, with a step of 0.4 V. This parameter cannot be set after successful BMS communication
12	Battery over-discharge voltage (delayed shutdown)	42	When the battery voltage is lower than the voltage and triggers the set value in the item 13, it will turn off the inverter output. Setting range: 40 V–48 V, with a step of 0.4 V
13	Battery over-discharge	5	When the battery voltage is lower than the set value in the item 12 and triggers the delay time set in this parameter item, it will turn off the inverter output. Setting range: 5s–50s, with a step of 5s

ID	Parameter	Option	Description
	delay time		
14	Battery under-voltage alarm threshold	44	When the battery voltage is lower than the threshold, it will give an under-voltage alarm and the output will not shut down. Setting range: 40 V–52 V, with a step of 0.4 V
15	Battery discharge limit voltage	40	When the battery voltage is lower than the value, the output immediately shuts down. Setting range: 40 V–52 V, with a step of 0.4 V, available for user-defined and Li-ion batteries
16	Battery equalizing charge	DIS( <b>default</b> )	Disable equalizing charge
		ENA	Enable equalizing charge, but only available for flooded lead-acid batteries, sealed lead-acid batteries, and user-defined ones
17	Equalizing charge voltage	58	Setting range: 48 V–58 V, with a step of 0.4 V, but only available for flooded lead-acid batteries, sealed lead-acid batteries, and user-defined ones
18	Equalizing charge duration	120	Setting range: 5 min – 900 min, with a step of 5 min, but only available for flooded lead-acid batteries, sealed lead-acid batteries, and user-defined ones
19	Equalizing charge delay time	240	Setting range: 5 min – 900 min, with a step of 5 min, but only available for flooded lead-acid batteries, sealed lead-acid batteries, and user-defined ones
20	Equalizing charge interval	30	Setting range: 0 day – 30 days, with a step of 1 day, but only available for flooded lead-acid batteries, sealed lead-acid batteries, and user-defined ones
21	Equalizing charge Enable/Disable	DIS ( <b>default</b> )	Stop equalizing charge immediately
		ENA	Start equalizing charge immediately
22	Energy-saving mode	DIS ( <b>default</b> )	Disable energy-saving mode
		ENA	Enable energy-saving mode, and when the load power is below 50 W, it will turn off the inverter output after a 5-minute delay. When it exceeds 50 W, the inverter will automatically restart.
23	Overload auto restart	DIS	Disable overload auto restart and when overload occurs, it will turn off the output and the inverter will no longer resume startup
		ENA ( <b>default</b> )	Enable overload auto restart, and If overload occurs, the output will be turned off, and after a delay of 3 min, the output will restart. After 5 cumulative attempts, the inverter will no longer resume startup
25	Buzzer alarm	DIS	Disable buzzer alarm
		ENA ( <b>default</b> )	Enable buzzer alarm
26	Mode switch prompt	DIS	Disable prompt when the status of the main input source changes

ID	Parameter	Option	Description
		ENA (default)	Enable prompt when the status of the main input source changes
27	Inverter to bypass switch	DIS	Disable auto switch to mains for loading in case of inverter overload
		ENA (default)	Enable auto switch to mains for loading in case of inverter overload
28	Grid charge current	60A	SPI-4K-UP setting range:0-60A
			SPI-5K-UP setting range:0-60A
			SPI-6K-UP setting range:0-80A
			SPI-6.5K-UP setting range:0-80A
30	RS485 communication address	ID: 1	Setting range: 1-254
31	Parallel mode ( When the rocker switch is off can be set )	SIG (default)	Single inverter operation
		PAL	Parallel operation
		2P0/2P1/2P2	Two-phase parallel operation
		Set to "2P0" for the machine screens connected to P1 Assuming that the output voltage of the setting item [38] is set to 120 VAC 1) When all the inverters connected to P2 are set to "2P1" on the screen, the voltage phase difference between P1 and P2 is 120°, the voltage between the live wire L1 of phase-P1 and the live wire L2 of phase-P2 is $120 \times 1.732 = 208$ VAC, and the voltage of L1-N and L2-N is 120 VAC. 2) When all the inverters connected to P2 are set to "2P2" on the screen, the voltage phase difference between P1 and P2 is 180°, the voltage between the live wire L1 of phase-P1 and the live wire L2 of phase-P2 is $120 \times 2 = 240$ VAC, and the voltage of L1-N and L2-N is 120 VAC.	
		3P1/3P2/3P3	Three-phase parallel operation
		Set to "3P1" on the screen for all the inverters connected to P1; set to "3P2" on the screen for all the inverters connected to P2; and set to "3P3" on the screen for those connected to P3. 1) Assuming that the output voltage of the setting item [38] is set to 120 VAC: then the voltage phase difference of P1-P2, P1-P3, and P2-P3 is 120°, the voltage between the live wire L1 of phase-P1 and the live wire L2 of phase-P2 is $120 \times 1.732 = 208$ VAC, and similarly the voltage of L1-L3 and L2-L3 is 208 VAC; the voltage of L1-N, L2-N, and L3-N is 120 VAC.	

ID	Parameter	Option	Description
32	RS485 communication function	DIS (default)	Enable PC and Remote Monitoring Protocol
		485	Enable the BMS communication function based on RS485 communication
		CAN	Enable the BMS communication function based on CAN communication
33	BMS communication	Select the corresponding communication protocol in item 33 when you set it to 485 or CAN in item 32	
		PAC = PACE, RDA = Ruida, AOG = Aoguan, OLT = Oliter, HWD = Sunwoda, DAQ = Daqin, WOW = SRNE, PYL = Pylontech, UOL = Vilion	
34	Limit power to CT (optional)	DIS (default)	Disable this function
		Home load	solar energy can be supplied to the home load that connected to the grid, excess energy will not be feed to the grid.
35	Battery under-voltage recovery threshold	52	When the battery is under voltage, the battery voltage needs to be greater than the threshold to restore the AC output of the battery inverter. Setting range: 44 V–54.4 V
37	Recharge voltage threshold for fully charged battery	52	After the battery is fully charged, the inverter stops charging, and recovers charging when the battery voltage is lower than the threshold. Setting range: 44 V–54 V
38	AC output voltage ( When the rocker switch is off can be set )	120	Setting range: 100/105/110/120 /127VAC If users change the voltage,the output power will be changed. SPI-6.5K-UP : 5.4kw/5.6kw/5.9kw/6.5kw/6.8kw SPI-6K-UP : 5kw/5.2kw/5.5kw/6kw/6.3kw SPI-5K-UP : 4.2kw/4.4kw/4.6kw/5kw/5.3kw SPI-4K-UP : 3.4kw/3.5kw/3.7kw/4kw/4.3kw
39	Charge current limit (when BMS works)	LCSET	The maximum battery charge current is not greater than the set value of [item 07]
		LCBMS (default)	The maximum battery charge current is not greater than the maximum value of BMS
		LCINV	The maximum battery charge current is not greater than the logical judgment value of inverter
40	Period-1 battery charge start time	00:00:00	Setting range: 00:00:00–23:59:00
41	Period-1 battery charge end time	00:00:00	Setting range: 00:00:00–23:59:00
42	Period-2 battery charge start time	00:00:00	Setting range: 00:00:00–23:59:00
43	Period-2 battery	00:00:00	Setting range: 00:00:00–23:59:00

ID	Parameter	Option	Description
	charge end time		
44	Period-3 battery charge start time	00:00:00	Setting range: 00:00:00–23:59:00
45	Period-3 battery charge end time	00:00:00	Setting range: 00:00:00–23:59:00
46	Timed battery charge function	DIS (default)	Disable the function
		ENA	After the timed mains charge/loading function is enabled, the power supply mode will turn into SBU, where mains is available for power supply in the set period or after battery over-discharge. If the timed discharge function is enabled at the same time, the power supply mode of the system will be changed into UTI, where mains is only available for power supply in the set charge period, and the system only switches to the power supply of battery inverter during the set discharge period or mains failure
47	Period-1 battery discharge start time	00:00:00	Setting range: 00:00:00–23:59:00
48	Period-1 battery discharge end time	00:00:00	Setting range: 00:00:00–23:59:00
49	Period-2 battery discharge start time	00:00:00	Setting range: 00:00:00–23:59:00
50	Period-2 battery discharge end time	00:00:00	Setting range: 00:00:00–23:59:00
51	Period-3 battery discharge start time	00:00:00	Setting range: 00:00:00–23:59:00
52	Period-3 battery discharge end time	00:00:00	Setting range: 00:00:00–23:59:00
53	Timed battery discharge function	DIS (default)	Disable the function
		ENA	After the timed battery discharge function is enabled, the power supply mode will be changed into UTI, where the system only switches to the power supply of battery inverter during the set discharge period or mains failure
54	Current date	00:00:00	Year/Month/Day Setting range: 00:01:01–99:12:31
55	Current time	00:00:00	Setting range: 00:00:00–23:59:59
56	Leakage current protection enable	DIS(default)	Disable leakage current protection
		ENA	Enable leakage current protection

ID	Parameter	Option	Description
57	Charge stop current	3	The charge stops when the charge current is less than the set value (unit: A)
58	SOC setting for discharge alarming	15	When the capacity is less than the set value, the SOC alarms (unit: %, only available during normal BMS communication)
59	SOC setting for discharge cutoff	5	When the capacity is less than the set value, the discharge stops (unit: %, only available during normal BMS communication)
60	SOC setting for charge cutoff	100	When the capacity is greater than the set value, the charge stops (unit: %, only valid during normal BMS communication)
61	SOC setting for switching to mains	10	When the capacity is less than the set value, it switches to mains (unit: %, only available during normal BMS communication)
62	SOC setting for switching to inverter output	100	When the capacity is greater than the set value, it switches to the inverter output mode (unit: %, only available during normal BMS communication)
63	Auto N-PE connection switch function	DIS (default)	Disable auto N-PE connection switch
		ENA	Enable auto N-PE connection switch
67	Power sales setting	0 (default)	Setting range: 0–rated power
68	AC output phase mode ( When the rocker switch is off can be set )	0	0 represents the single-phase mode Assuming that the AC output voltage of item 38 is 120 V, the phase difference of L1-L2 is 0°, and L1/L2 can be connected in parallel, the phase voltage of L1-N/L2-N is 120 V
		180 (default)	180 represents the split-phase mode Assuming that the AC output voltage of item 38 is 120 V, the phase difference of L1-L2 is 180°, the phase voltage of L1-N/L2-N is 120 V, and the voltage of L1-L2 is 240 V
		NO N	Without N-wire(When you set "No N", the phase difference is 180° default)
73	Max charging current by generator	40A	SPI-4K-UP setting range:0-60A
			SPI-5K-UP setting range:0-60A
			SPI-6K-UP setting range:0-80A
			SPI-6.5K-UP setting range:0-80A

ID	Parameter	Option	Description
74	Generator input power	6KW	setting range:0-10KW
76	CT ratio <b>(optional)</b>	1000	When connect an external CT, enter the current ratio according to CT specification.
77	Anti-reflux Error calibration power	100W	Setting range 0-500w
79	AFCI check <b>(optional)</b>	DIS( <b>default</b> )	Disable AFCI check function
		ENA	Enable AFCI check function
80	AFCI fault manually clear <b>(optional)</b>	IGNORE	Ignore the AFCI fault report
		CLEAR	Clear the AFCI fault

## 5.5 Timed charge/discharge function

SPI UPseries has the timed power charge/discharge function. Users can set different charge and discharge periods according to the local time-of-use price, thus reasonably using mains and PV power. When mains is expensive, the battery inverter is used to supply power to the load; when mains is cheap, it can be used to supply power to and charge the load, thus helping users reduce electricity expenses to the full extent. Users can turn on/off the timed charge/discharge function in items 46 and 53 in the setup menu, and set charge and discharge periods in parameters 40–45 and 47–52.

The following is an example to help users understand the function.

Before using the function for the first time, please set the local time and date in parameters 54 and 55, and then you can set corresponding periods based on the local time-of-use price.

**NOTICE**

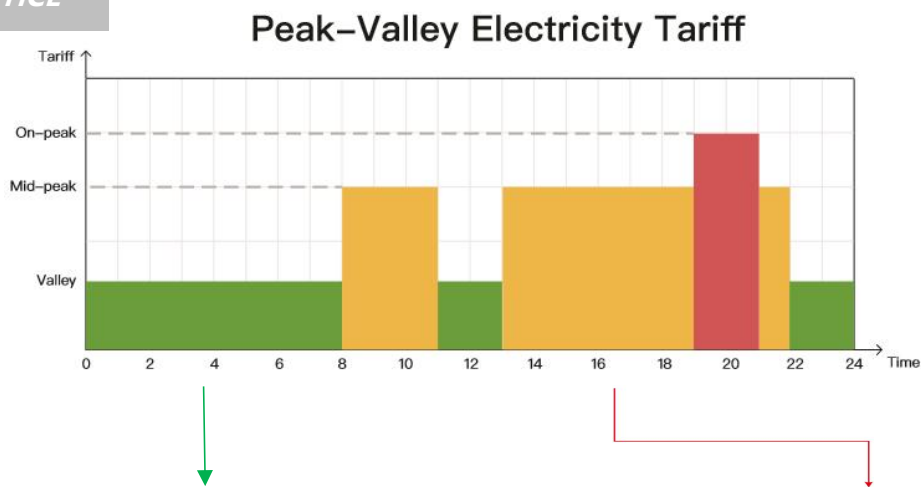

### Timed charge and loading function



With 3 definable periods, users can freely set the mains charge/loading period in the range of 00:00–23:59. During the period set by the user, in case of PV energy output, it will be used first; in case of no PV energy output or lack of PV energy, mains will be used as a supplement.

### Timed battery discharge function



With 3 definable periods, users can freely set the battery discharge period in the range of 00:00–23:59. During the period set by the user, the inverter will first use the battery inverter to load; if the battery power is insufficient, the inverter will automatically switch to mains to ensure stable operation of the load.

## 5.6 Battery parameters

- Lead-acid battery

<b>Battery type</b> <b>Parameters</b>	<b>Sealed lead acid battery (SLD)</b>	<b>Gel lead acid battery (GEL)</b>	<b>Flooded lead acid battery (FLD)</b>	<b>User-defined (USE)</b>	<b>Adjustable</b>
Overvoltage disconnection voltage	60V	60V	60V	60V	
Battery fully charged recovery point	52V	52V	52V	52V	√
Boost charge voltage	57.6V	56.8V	57.6V	40 ~ 60V	√
Undervoltage alarm voltage([01] fault)	44V	44V	44V	40 ~ 60V	√
Undervoltage alarm voltage recovery point([01] fault)	Undervoltage alarm voltage+0.8V				
Low voltage disconnection voltage([04] fault)	42V	42V	42V	40 ~ 60V	√
Low voltage disconnection voltage recovery point ([04] fault)(setup item [35])	52V	52V	52V	52V	√
Discharge limit voltage	-	-	-	40 ~ 60V	√
Over-discharge delay time	5s	5s	5s	1 ~ 30s	√
Boost charge duration	-	-	-	10 ~ 900 minutes	√

- **Li-ion battery**

<b>Battery type</b> <b>Parameters</b>	<b>Ternary (N13)</b>	<b>Ternary (N14)</b>	<b>LFP (L16)</b>	<b>LFP (L15)</b>	<b>LFP (L14)</b>	<b>Adjustable</b>
Overvoltage disconnection voltage	60V	60V	60V	60V	60V	
Battery fully charged recovery point	50.4V	54.8V	53.6V	50.4V	47.6V	√
Equalizing charge voltage	-	-	-	-	-	√
Boost charge voltage	53.2V	57.6V	56.8V	53.2V	49.2V	√
Undervoltage alarm voltage([01] fault)	43.6V	46.8V	49.6V	46.4V	43.2V	√
Undervoltage alarm voltage recovery point([01] fault)	Undervoltage alarm voltage+0.8V					
Low voltage disconnection voltage([04] fault)	38.8V	42V	48.8V	45.6V	42V	√
Low voltage disconnection voltage recovery point ([04] fault)(setup item [35])	46V	49.6V	52.8V	49.6V	46V	√
Discharge limit voltage	36.4V	39.2V	46.4V	43.6V	40.8V	√
Over-discharge delay time	30s	30s	30s	30s	30s	√
Boost charge duration	120 minutes	120 minutes	120 minutes	120 minutes	120 minutes	√

# 6. Communication

## 6.1 Overview

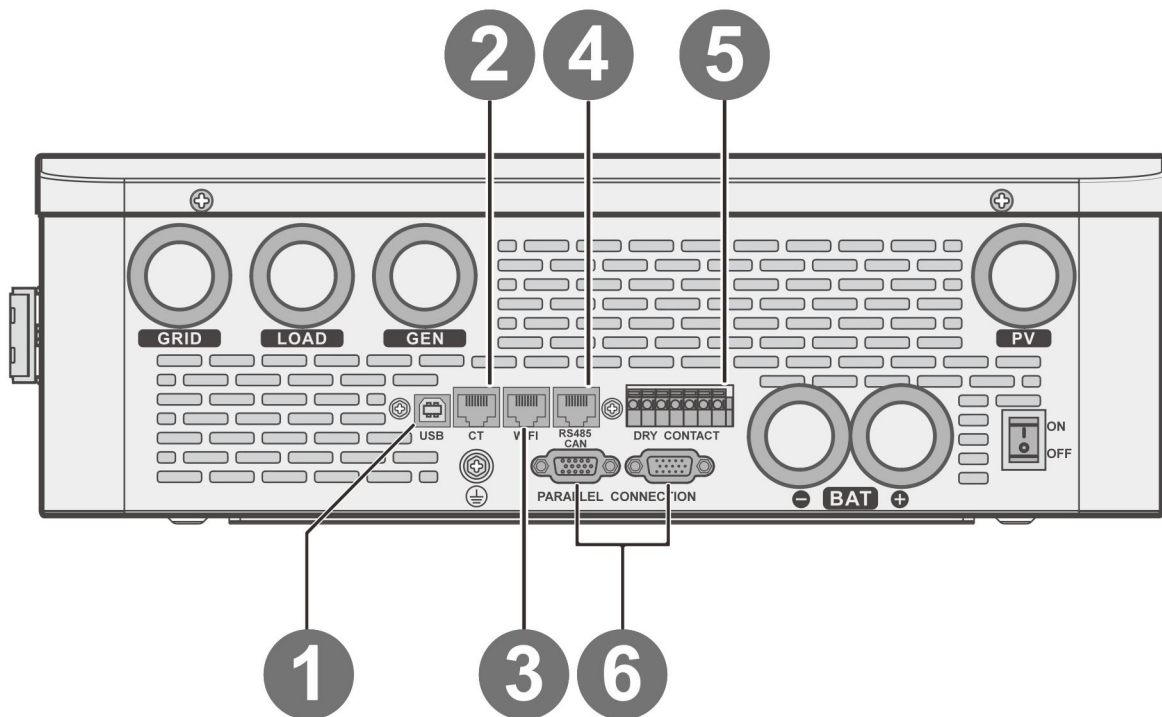

1	USB-B port	2	CT port	3	WIFI port
4	RS485/CAN port	5	Dry contact port	6	Parallel port

## 6.2 USB-B port

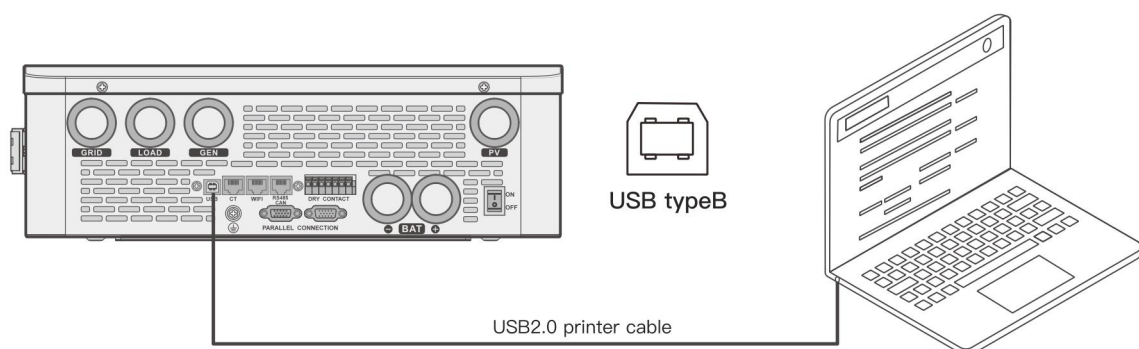

Users can use the upper computer software through the port to read and modify device parameters. If needing the installation package for the upper computer software, you can contact us to get it.

### 6.3 WIFI port

The WIFI port is used to connect to the Wi-Fi/GPRS data acquisition module, and then users can view the operation status and parameters of the inverter via the mobile APP.

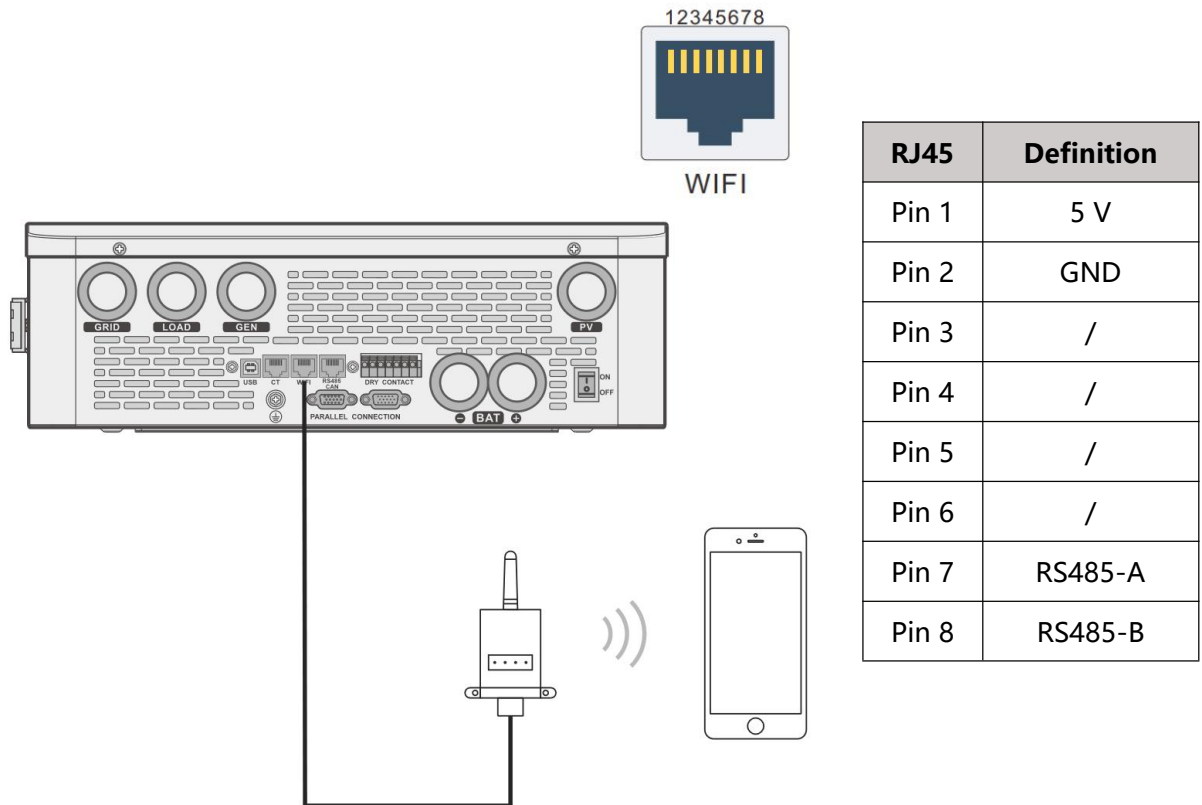

### 6.4 RS485/CAN port

The RS485/CAN port is used to connect to the BMS of the Li-ion battery.

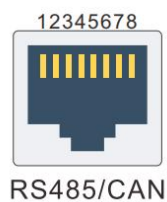

RJ45	Definition
Pin 1	RS485-B
Pin 2	RS485-A
Pin 3	/
Pin 4	CANH
Pin 5	CANL
Pin 6	/
Pin 7	RS485-A
Pin 8	RS485-B

### 6.5 CT port (optional)

Please contact us for firmware and CT if you need this function

CT direction : to inverter

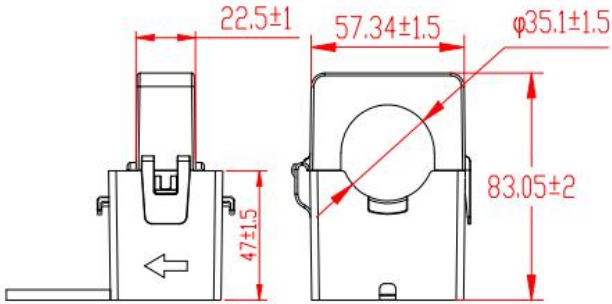
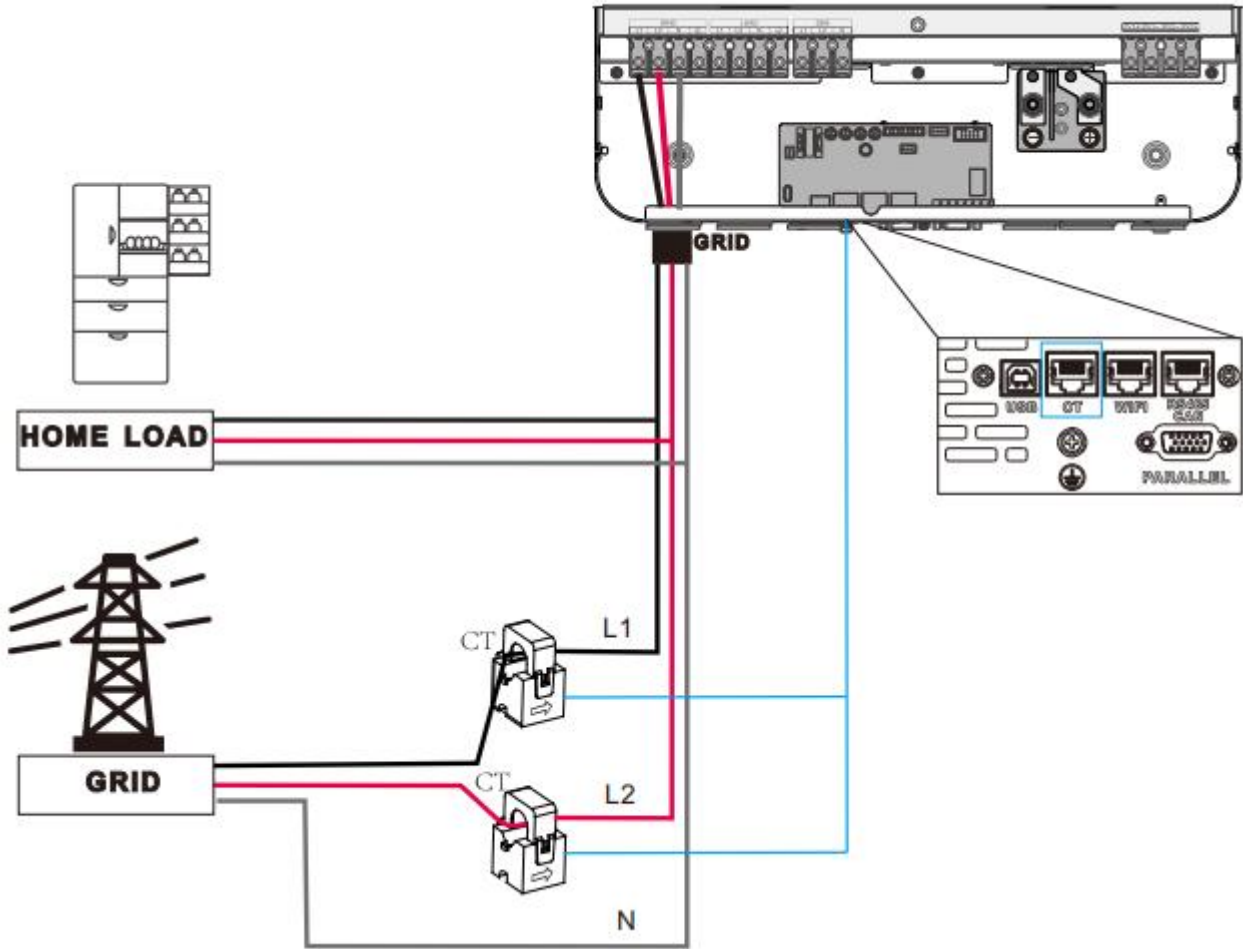

## 6.6 Dry contact port

The dry contact port has 4 functions:

1. RSD power supply
2. Remote ON/OFF
3. Battery temperature sampling
4. Remote generator start/stop

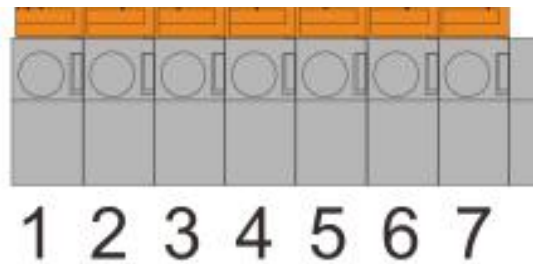

Function	Description
RSD power supply	PIN 1 is GND, PIN 2 is RSD 12V+
Remote ON/OFF	When pin 1 is connected to pin 3, the inverter will turn off the AC output. When disconnected, the inverter is in normal output.
Temperature sampling (reserved)	Pins 1 and 4 can be used for battery temperature sampling compensation.
Remote generator start/stop	When the battery voltage reaches the under-voltage alarm voltage (parameter 14) or the voltage threshold for mains to switch to the battery (parameter 04), pins 6 to 5 are normally open, and pins 7 to 5 are normally closed. When the battery voltage reaches the voltage threshold for the battery to switch to mains (parameter 05), or the battery is fully charged, pins 6 to 5 are normally closed, and pins 7 to 5 are normally open. (5/6/7 pin output: 125 VAC/1 A, 230 VAC/1 A, and 30 VDC/1 A)

### ⚠ NOTICE

If you need to use the remote start/stop function of the generator with dry contact, please ensure that the generator has an ATS and supports remote start/stop.

# 7. Fault Codes and Response Measures

## 7.1 Fault codes

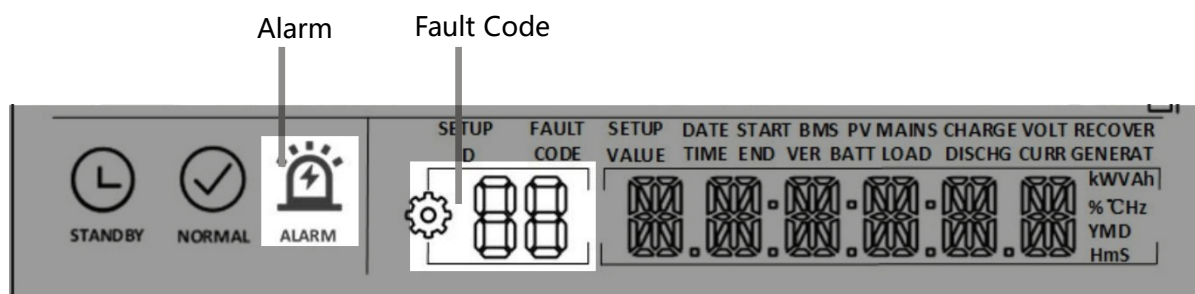

Fault Code	Meaning	Affect Output or Not	Description
01	BatVoltLow	Yes	Battery under-voltage alarm
02	BatOverCurrSw	Yes	Overcurrent software protection for average battery discharge current
03	BatOpen	Yes	Disconnected battery alarm
04	BatLowEod	Yes	Under-voltage battery discharge stop alarm
05	BatOverCurrHw	Yes	Battery overcurrent hardware protection
06	BatOverVolt	Yes	Charge overvoltage protection
07	BusOverVoltHw	Yes	Bus overvoltage hardware protection
08	BusOverVoltSw	Yes	Bus overvoltage software protection
09	PvVoltHigh	Yes	PV overvoltage protection
10	PvBoostOCSw	No	Boost overcurrent software protection
11	PvBoostOCHw	No	Boost overcurrent hardware protection
12	SpiCommErr	Yes	SPI communication fault of master and slave chips
13	OverloadBypass	Yes	Bypass overload protection
14	OverloadInverter	Yes	Inverter overload protection
15	AcOverCurrHw	Yes	Inverter overcurrent hardware protection
16	AuxDSpReqOffPWM	Yes	Slave chip OFF request fault
17	InvShort	Yes	Inverter short-circuit protection
18	Bussoftfailed	Yes	Bus soft-start failure
19	OverTemperMppt	No	PV heat sink over-temperature protection
20	OverTemperInv	Yes	Inverter heat sink over-temperature

			protection
21	FanFail	Yes	Fan fault
22	EEPROM	Yes	Memory fault
23	ModelNumErr	Yes	Model setting error
24	Busdiff	Yes	Positive and negative bus voltage imbalance
25	BusShort	Yes	Bus short-circuit
26	Rlyshort	Yes	Inverter AC output backward to bypass AC output
28	LinePhaseErr	Yes	Mains input phase error
29	BusVoltLow	Yes	Bus low-voltage protection
30	BatCapacityLow1	Yes	Alarm of battery capacity rate below 10% (taking effect after BMS communication is successful)
31	BatCapacityLow2	No	Alarm of battery capacity rate below 5% (taking effect after BMS communication is successful)
32	BatCapacityLowStop	Yes	Battery low-capacity OFF (taking effect after BMS communication is successful)
34	CanCommFault	Yes	Parallel can communication fault
35	ParaAddrErr	Yes	Parallel ID (communication address) setting error
37	ParaShareCurrErr	Yes	Parallel current sharing fault
38	ParaBattVoltDiff	Yes	Large battery voltage difference in parallel mode
39	ParaAcSrcDiff	Yes	Inconsistent mains input source in parallel mode
40	ParaHwSynErr	Yes	Hardware synchronization signal error in parallel mode
41	InvDcVoltErr	Yes	Inverter DC voltage error
42	SysFwVersionDiff	Yes	Inconsistent system firmware version in parallel mode
43	ParaLineContErr	Yes	Parallel connection fault
44	Serialnumbererror	Yes	Failure to set the serial number before leaving factory
45	Errorsettingofsplit-phasemode	Yes	Setting error of setting items in parallel mode
56	Lowinsulation	No	Abnormally low earth impedance of PV1+, PV2+, and PV-

	resistancefault		
<b>57</b>	Leakagecurrent overloadfault	Yes	System current leakage out of the standard
<b>58</b>	BMSComErr	No	BMS communication fault
<b>60</b>	BMSUnderTem	No	BMS under-temperature alarm (taking effect after BMS communication is successful)
<b>61</b>	BMSOverTem	No	BMS over-temperature alarm (taking effect after BMS communication is successful)
<b>62</b>	BMSOverCur	No	BMS overcurrent alarm (taking effect after BMS communication is successful)
<b>63</b>	BMSUnderVolt	No	BMS under-voltage alarm (taking effect after BMS communication is successful)
<b>64</b>	BMSOverVolt	No	BMS overvoltage alarm (taking effect after BMS communication is successful)

## 7.2 Troubleshooting

Fault Code	Meaning	Cause	Solution
/	No screen display	There is no power input, or the device switch at its bottom is not turned on	Check if the battery air-switch or PV air-switch has been closed; check if the switch is in "ON"; press any button on the screen to exit the screen sleep mode.
01	Battery under-voltage	The battery voltage is lower than the value set in parameter [14]	Charge the battery until the battery voltage exceeds the value set in parameter [14].
03	Disconnected battery	The battery is not connected, or the BMS of the lithium-ion battery is in the discharge protection state	Check if the battery is reliably connected; check if the circuit breaker of the battery is off; ensure that the BMS of the lithium-ion battery can communicate normally.
04	Battery over-discharge	The battery voltage is lower than the value set in parameter 12	Manual reset: Turn off the power, and restart Automatic reset: Charge the battery until the battery voltage is higher than the value set in parameter [35]
06	Rechargeable battery overvoltage protection	The battery is in the overvoltage state	Manually turn off the power, and restart Check if the battery voltage exceeds the limit. If the limit is exceeded, discharge the battery until the voltage is below the overvoltage recovery threshold of the battery
13	Bypass overload (software detection)	The output power or current of the bypass is overloaded within a certain period	Reduce the load power, and restart the device. For more details, please refer to item 11 in <i>Protection Function</i>
14	Inverter overload (software detection)	The output power or current of the inverter is overloaded within a certain period	
19	Over-high temperature of the heat sink for PV input (software detection)	The temperature of the heat sink for PV input exceeds 90°C for 3s	Wait until the temperature of the heat sink is below the over-temperature recovery temperature, when charge and discharge return to normal
20	Over-high	The temperature of the	

	temperature of the heat sink for inverter output (software detection)	heat sink for inverter output exceeds 90°C for 3s	
21	Fan fault	Software detection finds the fan has a fault	Shut down, manually flick the fan, and check if any foreign objects are blocking it
26	AC input relay short-circuit	Stuck relay for AC output	Manually shut down, and restart. If the fault occurs again after restarting, contact the after-sales service personnel to repair the machine
28	Mains input phase fault	The phase of AC input is inconsistent with that of AC output	Ensure that the phase of AC input is the same as that of AC output. For example, if the output is in the split-phase mode, the input shall also be in the split-phase mode.

**① NOTICE**

If you encounter product faults that cannot be solved by the methods listed in the above table, please contact our after-sales service department for technical support, and do not disassemble the device by yourself.

# 8. Protection Function and Product Maintenance

## 8.1 Protection function

No	Protection Function	Description
1	PV current-limiting protection	When the charge current or power of the configured PV array exceeds the rated current and power of the inverter, it will charge at the rated current and power
2	PV overvoltage protection	If the PV voltage exceeds the maximum allowable value of hardware, the machine will report the fault, and stop the step-up of PV to output sine AC waves
3	Reverse charge protection at night	At night, as the battery voltage is greater than that of the PV module, it will prevent the battery from discharging to the PV module
4	mains input overvoltage protection	When the mains voltage of each phase exceeds 140 VAC, it will stop mains from charging, and switch it to inverter output
5	Mains input under-voltage protection	When the mains voltage of each phase is lower than 90 VAC, it will stop mains from charge, and switch it to inverter output
6	Battery overvoltage protection	When the battery voltage reaches the overvoltage disconnect voltage threshold, it will automatically stop PV and mains from charging the battery, thus preventing damage to the battery due to overcharge
7	Battery under-voltage protection	When the battery voltage reaches the low-voltage disconnect voltage threshold, it will automatically stop discharging the battery, thus preventing damage to the battery due to overdischarge
8	Battery overcurrent protection	When the battery current exceeds the allowable range of hardware, the machine will turn off the output, and stop discharging the battery
9	AC output short-circuit protection	When a short-circuit fault occurs at the load output terminal, it will immediately turn off the output of AC voltage. Only after manually powering on the device, normal output restores
10	Heat sink over-temperature protection	When the internal temperature of the inverter is too high, the inverter will stop charging and discharging; when the temperature returns to normal, the inverter will charge and discharge again
11	Overload protection	After overload protection is triggered, the inverter output will be restored after 3 min, and after 5 times of overload, the output will

		<p>be off until the frequency changer is restarted.</p> <p>(102% &lt; load &lt; 110%): An error will be reported, and the output will be turned off after 5 min.</p> <p>(110% &lt; load &lt; 125%): An error will be reported, and the output will be turned off after 10s.</p> <p>Load &gt; 125%: An error will be reported, and the output will be turned off after 5s.</p>
<b>12</b>	AC backward protection	Prevent the mains of battery inverter backward to bypass AC input
<b>13</b>	Bypass overcurrent protection	Built-in circuit breaker for AC input overcurrent protection
<b>14</b>	Bypass wiring error protection	When the phase of the two bypass inputs is different from that of the inverter split-phase, the machine will prohibit connecting to the bypass, thus preventing the power failure or short circuit of load when connecting to the bypass

## 8.2 Maintenance

In order to maintain the best long-term performance, it is recommended to conduct following checks twice a year.

1. Make sure that the airflow around the inverter is smooth, and remove any dirt or debris from the heat sink.
2. Check whether the insulation of all exposed wires is damaged by exposure to sunlight, friction with other objects around them, dryness, bite by insects or rodents, etc. Repair or replace wires if necessary.
3. Verify the consistency of the indication and display with the device operation. Please pay attention to any faults or errors, and take corrective actions if necessary.
4. Check all wiring terminals for corrosion, insulation damage, and signs of high temperature or burning/discoloration, and tighten the terminal screws.
5. Check for dirt, nesting insects, and corrosion, clean up as required, and clean the insectproof net regularly.
6. If the arrester fails, replace it in time against lightning damage to the inverter or even other devices of the user.



**DANGER**

- Before conducting any inspection or operation, please ensure that the inverter is disconnected from all power sources and that the capacitor is fully discharged to avoid the risk of electric shock.

**Our company will not be held responsible for damage due to the following reasons:**

1. Damage caused by improper use or use in the wrong location.
2. The open circuit voltage of the PV module exceeds the maximum allowable voltage.
3. The operating temperature exceeds the limited operating temperature range.
4. Unauthorized personnel dismantle, and repair the inverter.
5. Force majeure: damage during transportation or handling of the inverter

## 9. Data sheet

Inverter Model	SPI-4K-UP	SPI-5K-UP	SPI-6K-UP	SPI-6.5K-UP	Settable
<b>Inverter output</b>					
Rated output power	4000W	5000W	6000W	6500W	
Maximum peak power	8000VA	10000VA	12000VA	13,000 VA	
Rated output voltage	120/240 VAC (single-phase/split-phase)				Y
Rated frequency	50/60 Hz				Y
Output wave	Pure sine wave				
Switching time	10 ms (typical value)				
Parallel number	6				
<b>Battery</b>					
Battery type	Lithium-ion battery/lead-acid battery/user-defined battery				Y
Rated battery voltage	48 Vdc				
Voltage range	40 Vdc–60 Vdc				Y
Maximum mains/generator charge current	60A	60A	80A	80 A	Y
Maximum mix charge current	100A	120A	140A	140 A	Y
<b>PV input</b>					
MPPT channel number	2				
Maximum input power	3000W+3000W	3800W+3800W	4500W+4500W	5000W+5000W	
Maximum Input Current	18/18 A				
Maximum open circuit voltage	550 Vdc+550Vdc				
MPPT operating voltage range	150 Vdc–450 Vdc				
<b>Mains/generator input</b>					
Input voltage	65 VAC–140 VAC				

range		
Input frequency range	50/60 Hz	
Bypass overload current	40A	
<b>Efficiency</b>		
MPPT tracking efficiency	99.9%	
Maximum efficiency of battery inverter	93%	
<b>General</b>		
Dimension	584.6mm*410 mm*133 mm	
Weight	18.9 kg	
Protection level	IP20, for indoor use only	
Ambient temperature	-10°C-55°C, >45°C derating	
Noise	<60 dB	
Cooling mode	Intelligent fan	
<b>Communication</b>		
Built-in interface	RS485/CAN/USB/dry contact	Y
External module (optional)	Wi-Fi/GPRS	Y
<b>Certification</b>		
Safety	IEC62109-1, IEC62109-2, and UL1741	
EMC	EN61000-6-1, EN61000-6-3, and FCC 15 class B	
RoHS	Yes	