

USER MANUAL



All-in-one solar charge inverter

SPI-10K-SP

SPI-8K-SP

Table of Contents

1. Safety

1.1 How to use this manual	4
1.2 Symbols in this manual	4
1.3 Safety instruction	4

2. Production Instructions

2.1 Instructions	5
2.2 Features	5
2.3 System connection diagram	6
2.4 Production overview	7

3. Installation

3.1 Select the mount location	8
3.2 Mount the inverter	9
3.3 Remove the terminal cover	9
3.4 Parallel wiring connection	10
3.4.1 Instruction	10
3.4.2 Precautions for connecting the parallel connection cable	10
3.4.3 Single-phase parallel connection guide diagram	11
3.4.4 Three-phase parallel connection guide diagram	14

4. Connection

4.1 Single-phase output	20
4.2 Cable & circuit breaker requirement.....	22
4.3 AC input&output connection.....	24
4.4 Battery connection	24
4.5 PV connection	25
4.6 Dry contact connection	26
4.7 Grounding connection	26
4.8 Final assembly.....	26
4.9 Start up the inverter	26

5. Operation

5.1 Operation and display panel	27
5.2 Setting	31

Table of Contents

5.3 AC output mode	37
5.4 Battery charging mode	38
5.5 Time-slot charging/discharging function	40
5.6 Battery parameter	41

6. Communication

6.1 Overview	43
6.2 USB-B port	43
6.3 RS485-1 port	44
6.4 CAN/RS485-2 port	44
6.5 Dry contact	45

7. Fault and Remedy

7.1 Fault code	46
7.2 Troubleshooting.....	48

8. Protection and Maintenance

8.1 Protection features	49
8.2 Maintenance	50





9. Datasheet	51
--------------------	----

1. Safety

1.1 How to use this manual

- This manual contains important information, guidelines, operation and maintenance for the following products: SPI-10K-SP, SPI-8K-SP
- The manual must be followed during installation, using and maintenance.

1.2 Symbols in this manual

Symbol	Description
	DANGER indicates a hazardous situations which if not avoided will result in death or serious injury.
	WARNING indicates a hazardous situations which if not avoided could result in death or serious injury.
	CAUTION indicates a hazardous situations which if not avoided could result in minor or moderate injury.
	NOTICE provides some tips on operation of products.

1.3 Safety instruction

DANGER

- This chapter contains important safety instructions. Read and keep this manual for future reference.
- Be sure to comply the local requirements and regulation to install this inverter.
- Beware of high voltage. Please turn off the switch of each power sources before and during the installation to avoid electric shock.
- For optimum operation of this inverter, please follow required specification to select appropriate cable size and necessary protective device.
- Do not connect or disconnect any connections when the inverter is working.
- Do not open the terminal cover when the inverter working.
- Make sure the inverter is well grounding.
- Never cause AC output and DC input short circuited.
- Do not disassembly this unit, for all repair and maintenance, please take it to the professional service center.
- Never charge a frozen battery.

2. Production Instructions

2.1 Instructions

SPI series is a new type of solar energy storage inverter control inverter integrating solar energy storage & utility charging and energy storage, AC sine wave output. It adopts DSP control and features high response speed, reliability, and industrial standard through an advanced control algorithm.

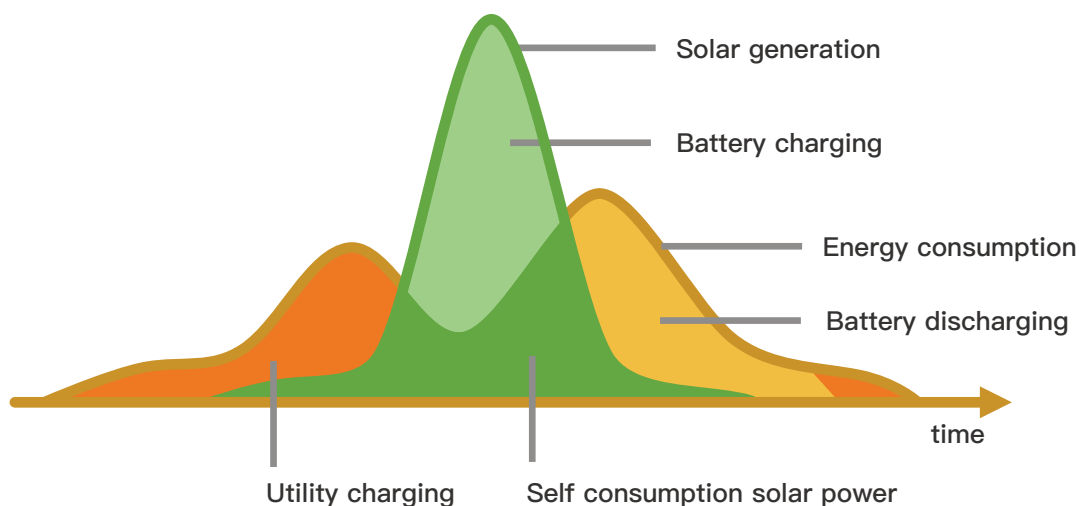

2.2 Features

- Supports lead acid battery and li-ion battery connections.
- With a dual activation function when the li-ion battery is dormant; either mains or photovoltaic power supply access can trigger the activation of the li-ion battery.
- Supports single-phase parallel and parallel three-phase pure sine wave output.
- Stand-alone or parallel systems support 200, 208, 220, 230 and 240Vac voltage levels
- Supports two solar inputs and simultaneous tracking of two solar maximum power charging/carrying capacity functions.
- Dual MPPT with 99.9% efficiency and maximum 22A current in a single circuit, perfectly adapted to high power modules.
- 4 charging modes are available: solar only, mains priority, solar priority, and mixed mains and PV charging.
- Time-slot charging and discharging setting function is available in both off-grid and hybrid grid-connected modes.
- Stand-alone energy saving mode function to reduce no-load energy losses.
- With two output modes of utility bypass and inverter output, with uninterrupted power supply function.
- LCD large screen dynamic flow diagram design, easy to understand the system data and operation status.
- 360° protection with complete short circuit protection, over current protection, over under voltage protection, overload protection, etc.
- Support CAN, USB, and RS485 communication.
- With N grounding option.

2.3 System connection diagram

The diagram below shows the system application scenario of this product. A complete system consists of the following components:

1. **PV modules:** converts light energy into DC energy, which can be used to charge the battery via an inverter or directly inverted into AC power to supply the load.
2. **Utility grid or generator:** connected to the AC input, it can supply the load and charge the battery at the same time. The system can also operate generally without the mains or generator when the battery and the PV module power the load.
3. **Battery:** The role of the battery is to ensure the regular power supply of the system load when the solar energy is insufficient and there is no mains power.
4. **Home load:** Various household and office loads can be connected, including refrigerators, lamps, televisions, fans, air conditioners, and other AC loads.
5. **Inverter:** The energy conversion device of the whole system.

The actual application scenario determines the specific system wiring method.

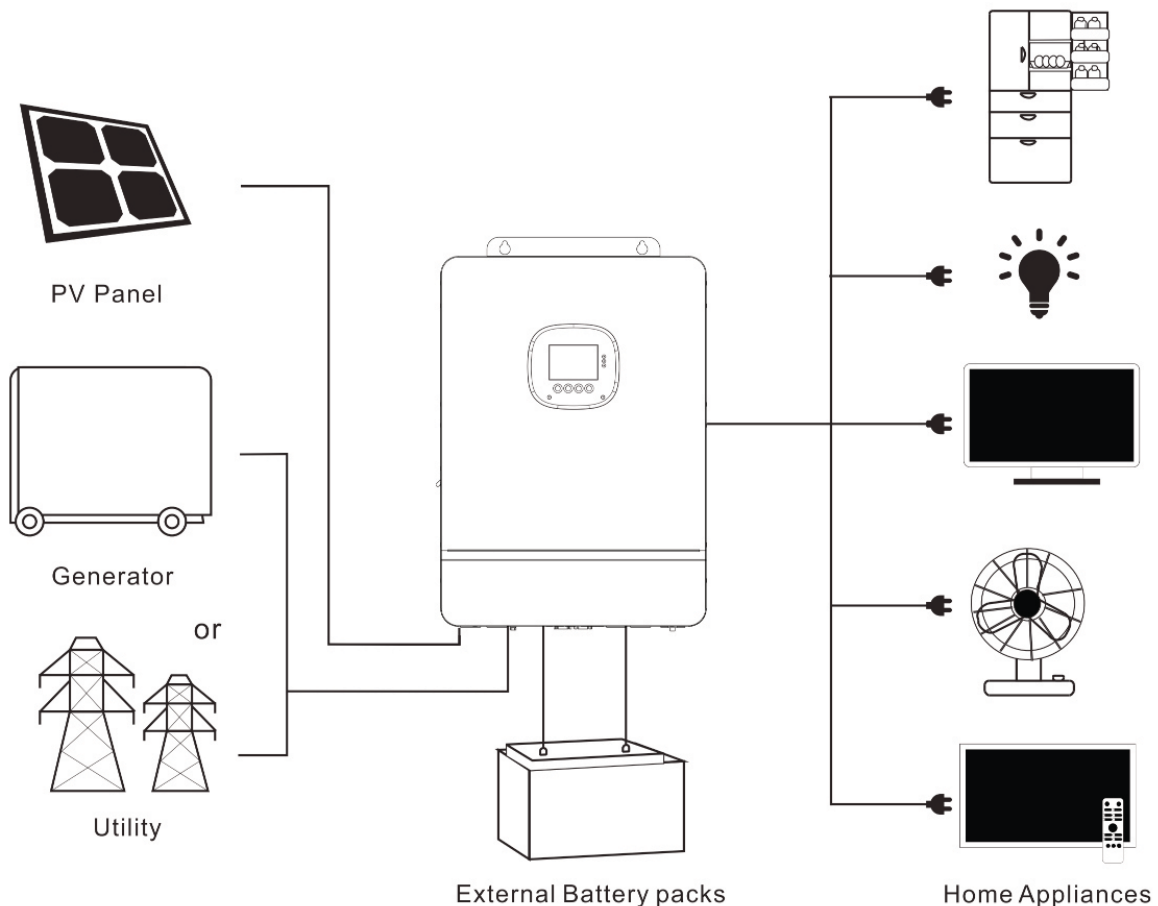

2.4 Production overview

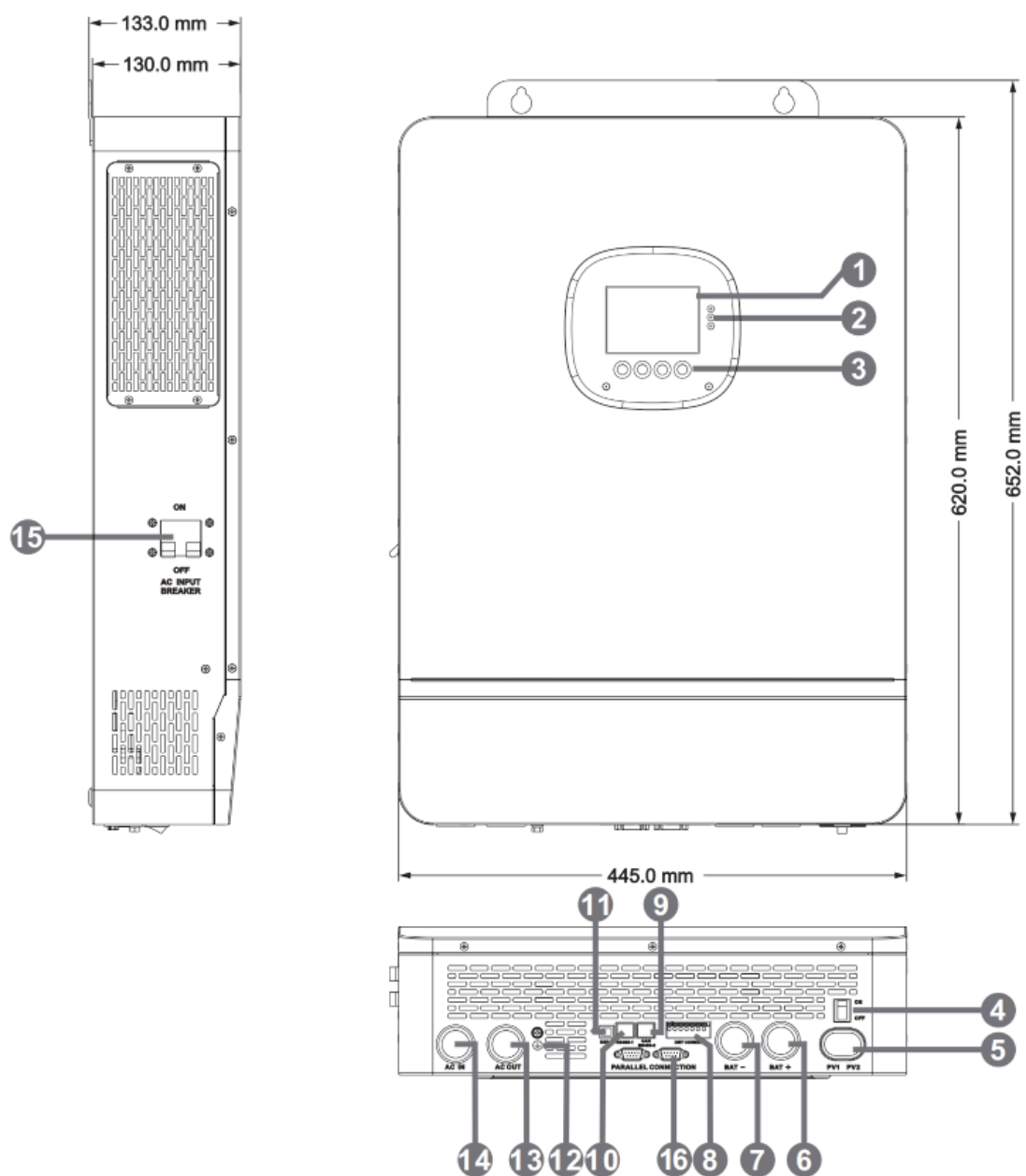

1	LCD screen	2	Touchable key	3	LED Indicators
4	ON/OFF Rocker Switch	5	PV INPUT (1/1)	6	BAT INPUT (+)
7	BAT INPUT (-)	8	Dry contact	9	CAN/RS485-2 port
10	RS485-1 port	11	USB-B port	12	Grounding Screw
13	AC OUT (L+N)	14	AC IN (L+N)	15	AC INPUT breaker
16	Parallel Communication port (Only for parallel modules)				

3. Installation

3.1 Select the mount location

SPI series are designed for INDOOR USE ONLY (IP20) . Please consider the followings before selecting the location.

- Choose the solid wall to install the inverter.
- Mount the inverter at eye level.
- Adequate heat dissipation space must be provided for the inverter.
- The ambient temperature should be between $-10\sim 55^{\circ}\text{C}$ ($14\sim 131^{\circ}\text{F}$) to ensure optimal operation.

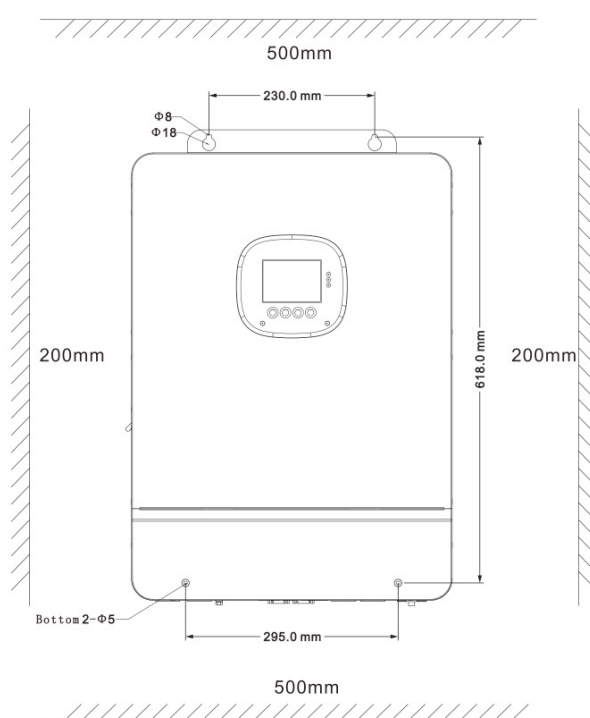

⚠ DANGER

- Do not install the inverter where highly flammable materials are near by.
- Do not install the inverter in potential explosive areas.
- Do not install the inverter with lead-acid batteries in a confined space.

⚠ CAUTION

- Do not install the inverter in direct sunlight.
- Do not install or use the inverter in a humid environment.

3.2 Mount the inverter

Make 4 mounting holes in the wall with a drill according to the specified dimensions, insert two expansion screws above and two M5 size screws below for fixing the inverter.

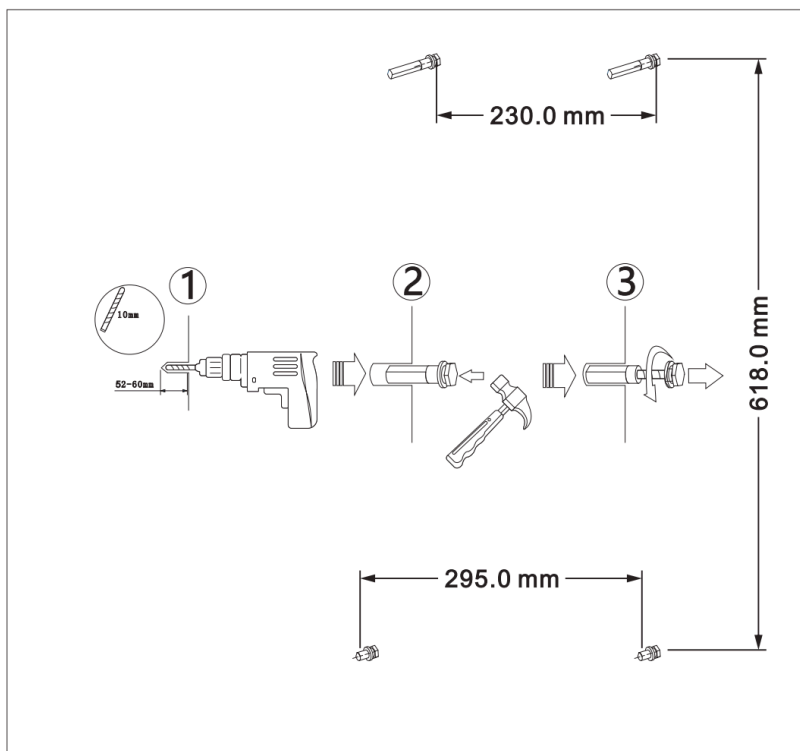

3.3 Remove the terminal cover

Using a screwdriver, remove the terminal protection cover.

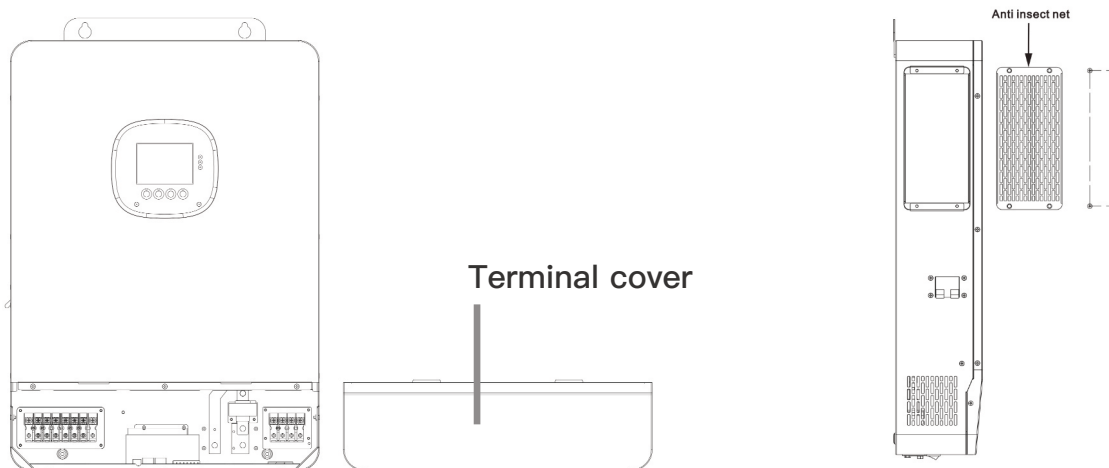

! NOTICE

- When using the device in areas with poor air quality, the dust screen is easily blocked by airborne particles. Please dismantle and clean the dust screen regularly to avoid affecting the internal air flow rate of the inverter, which may trigger an over-temperature protection fault (19/20 fault) affecting the use of the power supply and the service life of the inverter.

3.4 Parallel wiring connection

3.4.1 Introduction

- Up to six machines can be integrated into the reverse control module.
- When using the parallel function, it is necessary to correctly. Securely and reliably connect the parallel communication cable, as shown in the following connection diagram (packaging accessories) :

Parallel Communication Cable * 1

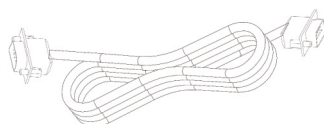

3.4.2 Precautions for connecting the parallel connection cable

Warning: 

1. PV Wiring:

When connected in parallel, different machines need to be connected to different PV arrays or PV sources. You cannot connect the same PV to different machines. The machine's PV1 and PV2 must not be connected to the same PV source.

2. Battery Wiring:

For single-phase or three-phase parallel connections, all inverse control units must be connected to the same battery, BAT+ to BAT+ and BAT- to BAT-. And make sure that the connections are correct and that the wires are of the same length and diameter before powering on the machine. Avoid wiring errors causing parallel system outputs improper operation.

3. AC OUT Wiring:

a. Single-phase parallel lines

When connecting single-phase parallel machines, all inverse control units must be connected L to L, N to N wire and PE to PE. And make sure that the connections are correct and that the wires are of the same length and diameter before powering on the machine. Avoid wiring errors causing parallel system outputs improper operation. Wiring reference 2.4.3 Diagram.

b. Three-phase parallel lines

When connecting three-phase parallel machines, all inverse control units must be connected N to N wire and PE to PE. The L-wires of all machines in the same phase need to be connected together, but the L-wires of the AC outputs of different phases cannot be connected together. Other considerations as for parallel single-phase connection. Wiring reference 2.4.4 Diagram.

4. AC IN Wiring:

a. Single-phase parallel lines

When connecting single-phase parallel machines, all inverse control units must be connected L to L, N to N wire and PE to PE. And make sure that the connections are correct and that the wires are of the same length and diameter before powering on the machine. Avoid wiring errors causing parallel system outputs improper operation. At the same time, there must not be more than one different AC source input, avoiding damage to the inverter or external electrical equipment. Consistency and uniqueness of the AC source input is required. Wiring reference 2.4.3 Diagram.

b. Three-phase parallel lines

When connecting three-phase parallel machines, all inverse control units must be connected N to N wire

and PE to PE. The L-wires of all machines in the same phase need to be connected together, but the L-wires of the AC inputs of different phases cannot be connected together. Other considerations as for parallel single-phase connection. Wiring reference 2.4.4 Diagram.

5. Parallel Communication Cable Wiring:

Our parallel communication cable is a standard DB15 computer cable with shielding. When using single-phase or three-phase machines in parallel, each machine must be connected one out and one in. This means that the male connector (out) of the machine is connected to the female connector (in) of the machine to be connected. Does not allow local male connectors to connect to local female connectors. At the same time make sure that the parallel communication cable is tightened through the DB15 terminal screw, which avoids disconnection or poor contact of the parallel communication cable leading to system output not working properly or damaged.

3.4.3 Single-phase parallel connection guide diagram

1. Parallel communication line and even flow detection line of inverse control unit need to be connected after screw locking. The schematic diagram is as follows:

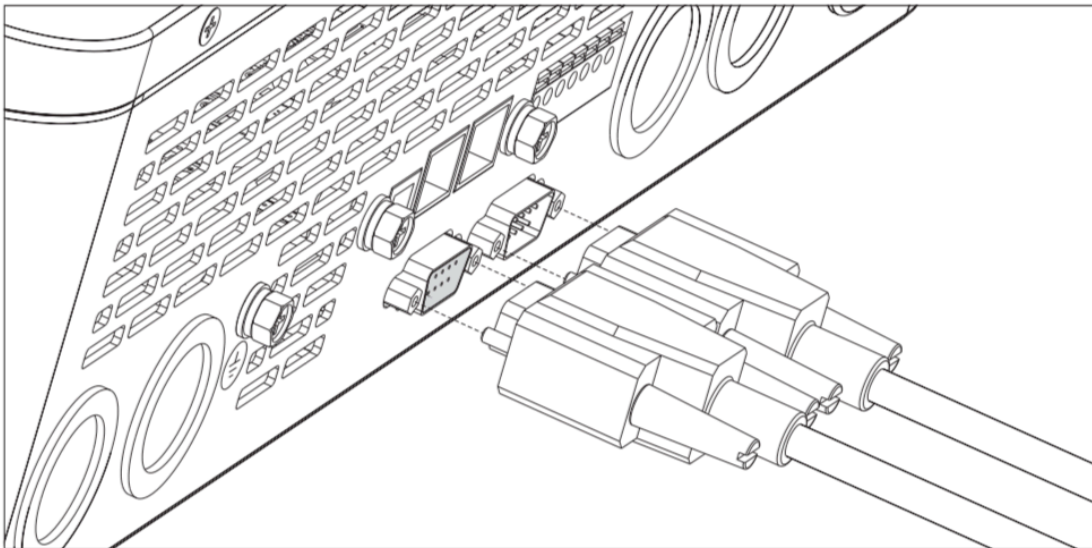

2. When multiple machines are connected in parallel, the parallel connection diagrams are as follows:

a. Two all-in-one solar charger inverters of the system connected in parallel

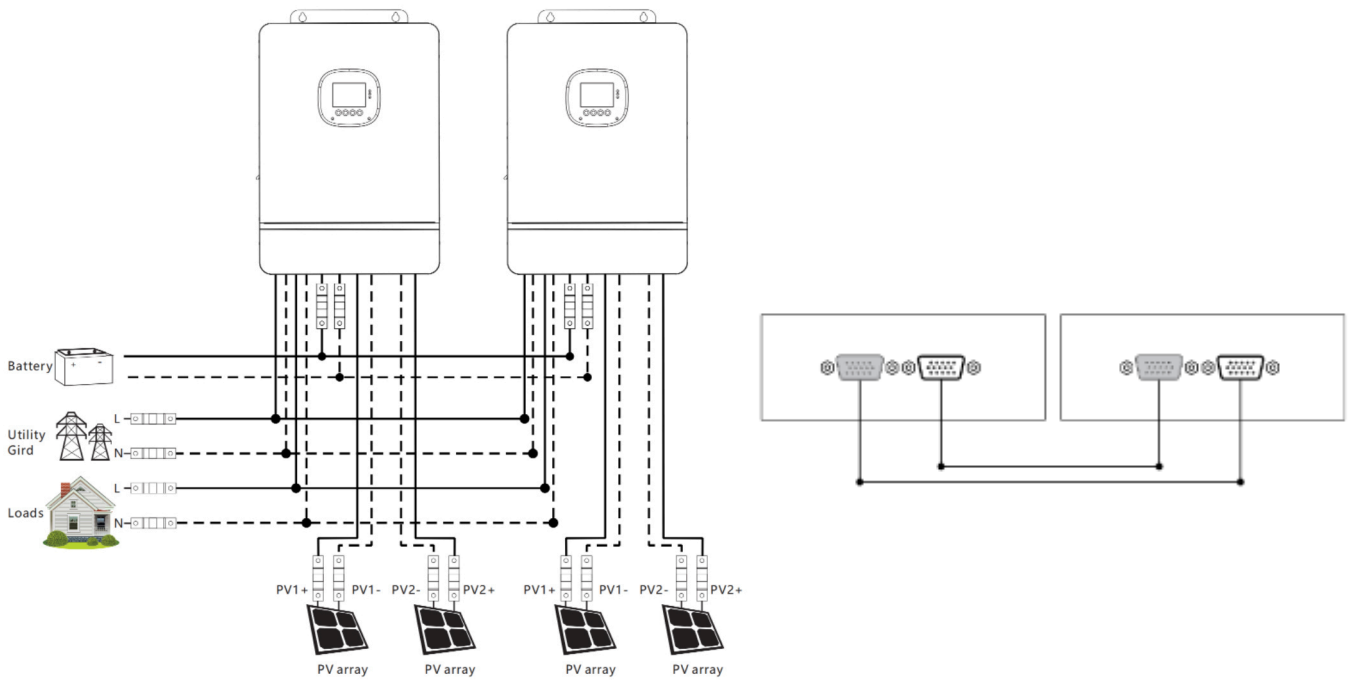

b. Three all-in-one solar charger inverters of the system connected in parallel

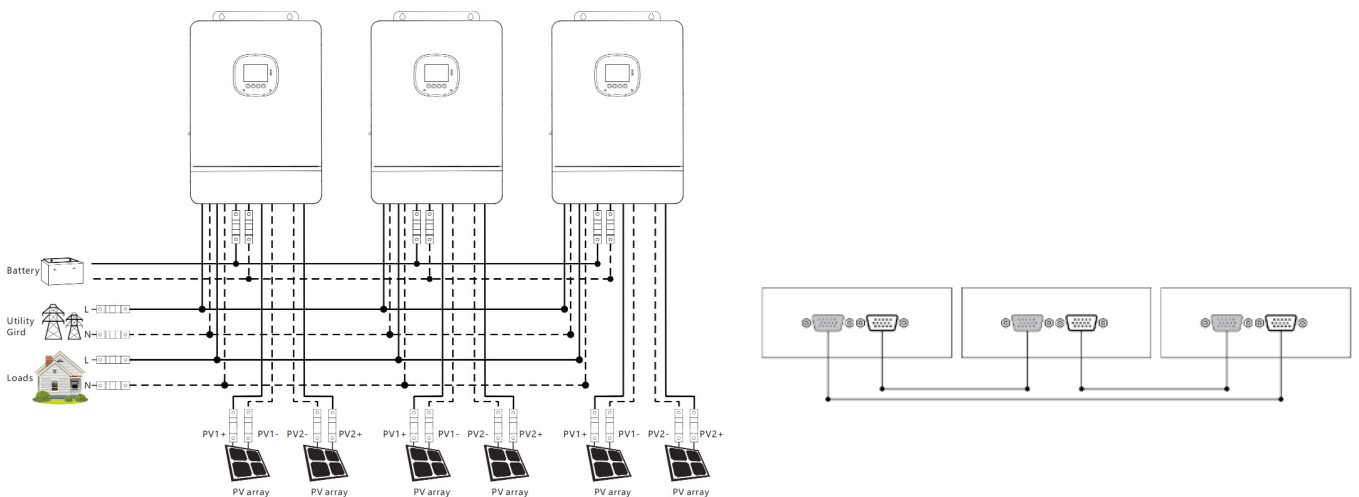

c. Four all-in-one solar charger inverters of the system connected in parallel

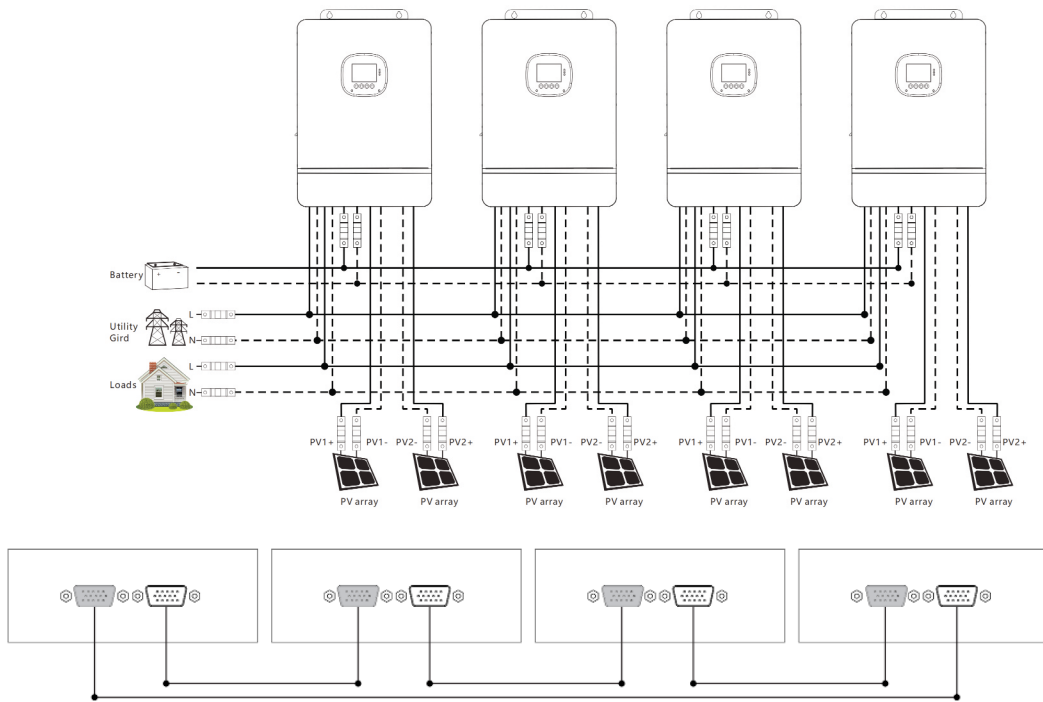

d. Five all-in-one solar charger inverters of the system connected in parallel

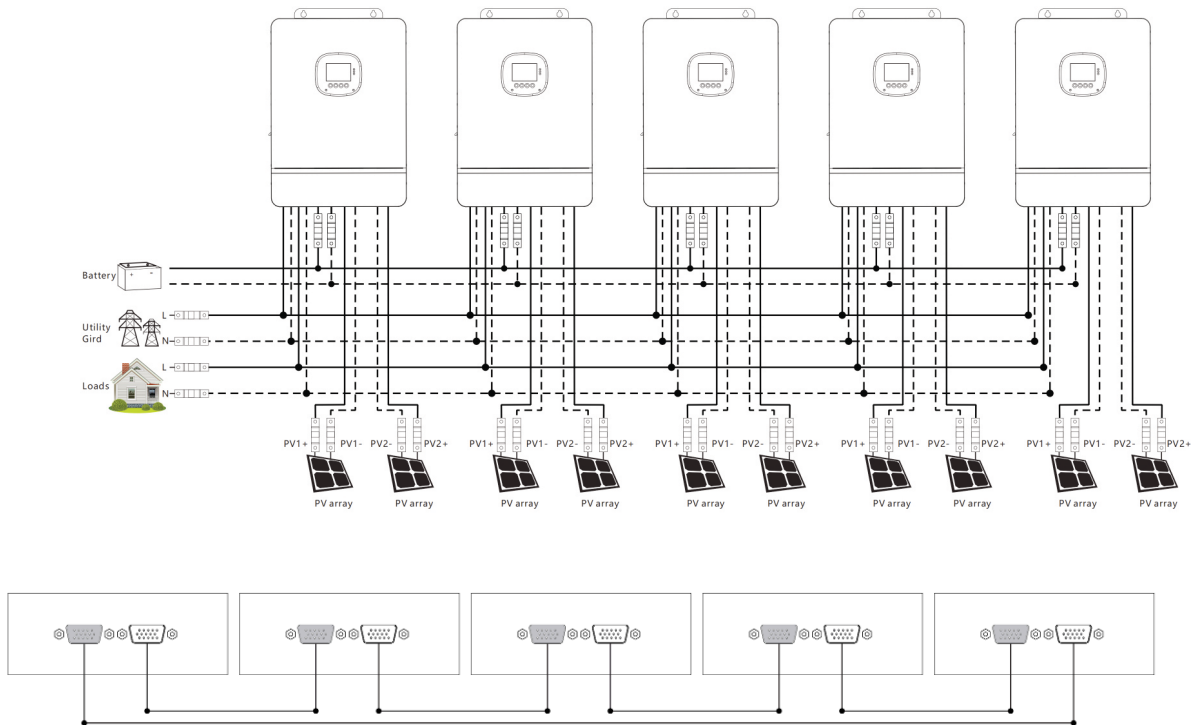

e. Six all-in-one solar charger inverters of the system connected in parallel

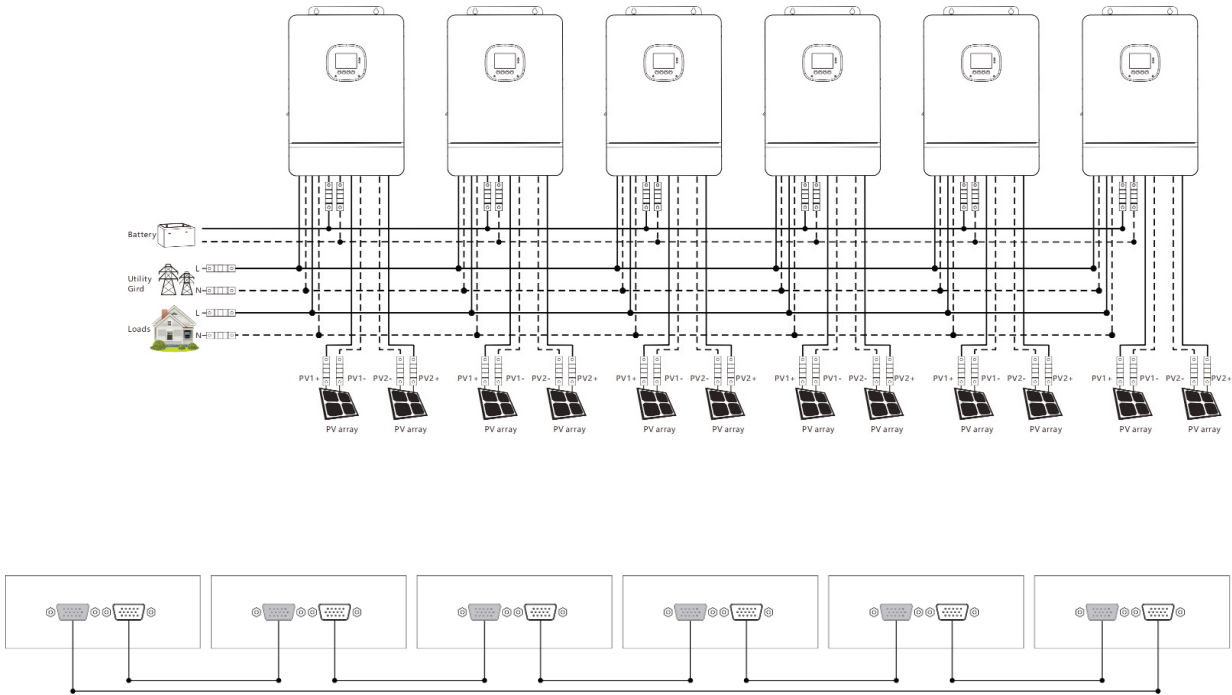

3.4.4 Three-phase parallel connection guide diagram

1. Parallel communication line of the inverters needs to be connected and then screwed and locked. The schematic diagram is as follows:

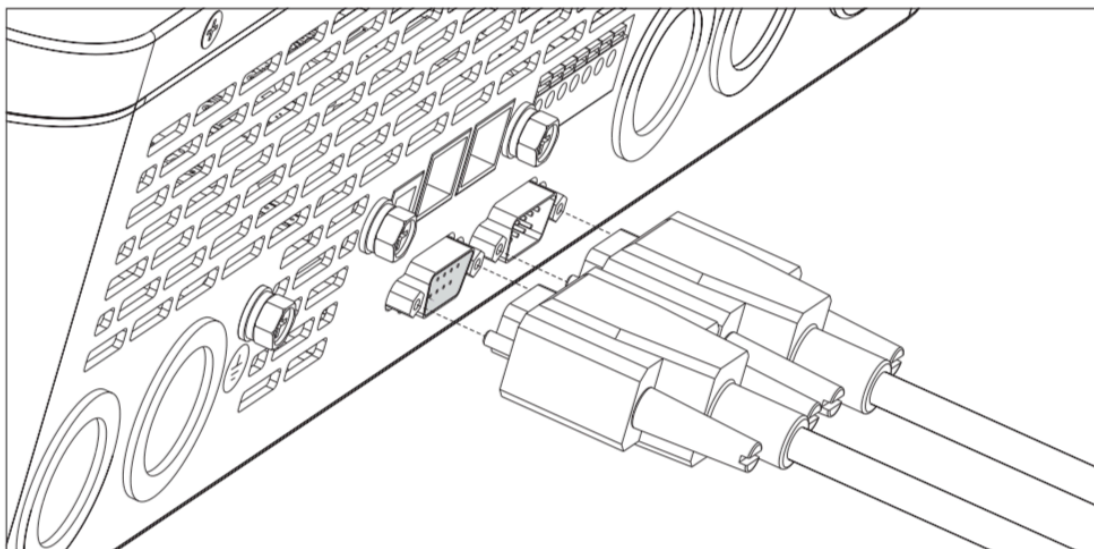

Three-phase parallel

a. Three all-in-one solar charger inverters of the system connected in three phase

1+1+1 system:

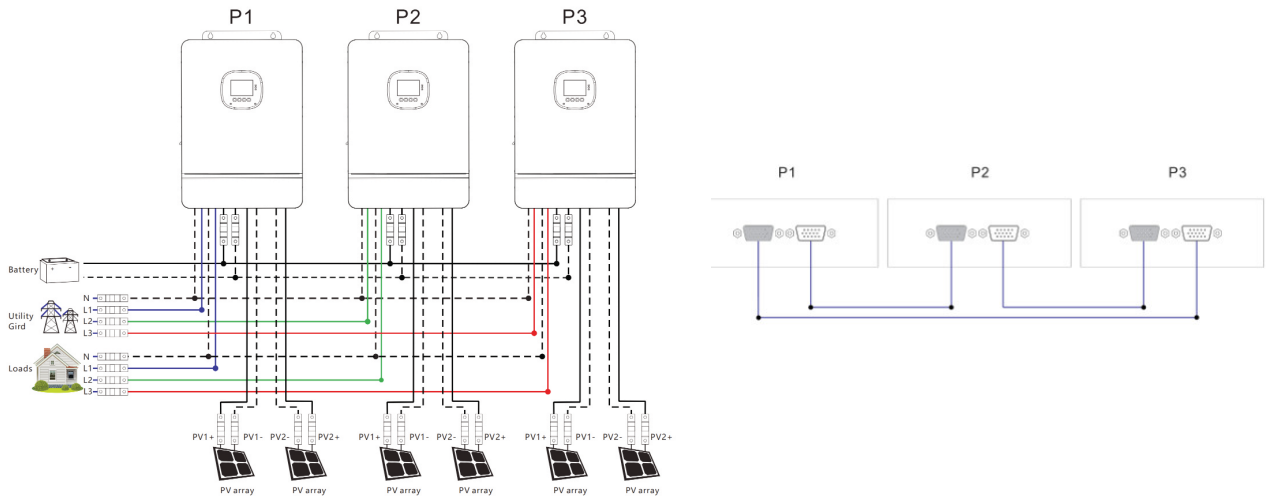

b. Four all-in-one solar charger inverters of the system connected in three phase

2+1+1 system:

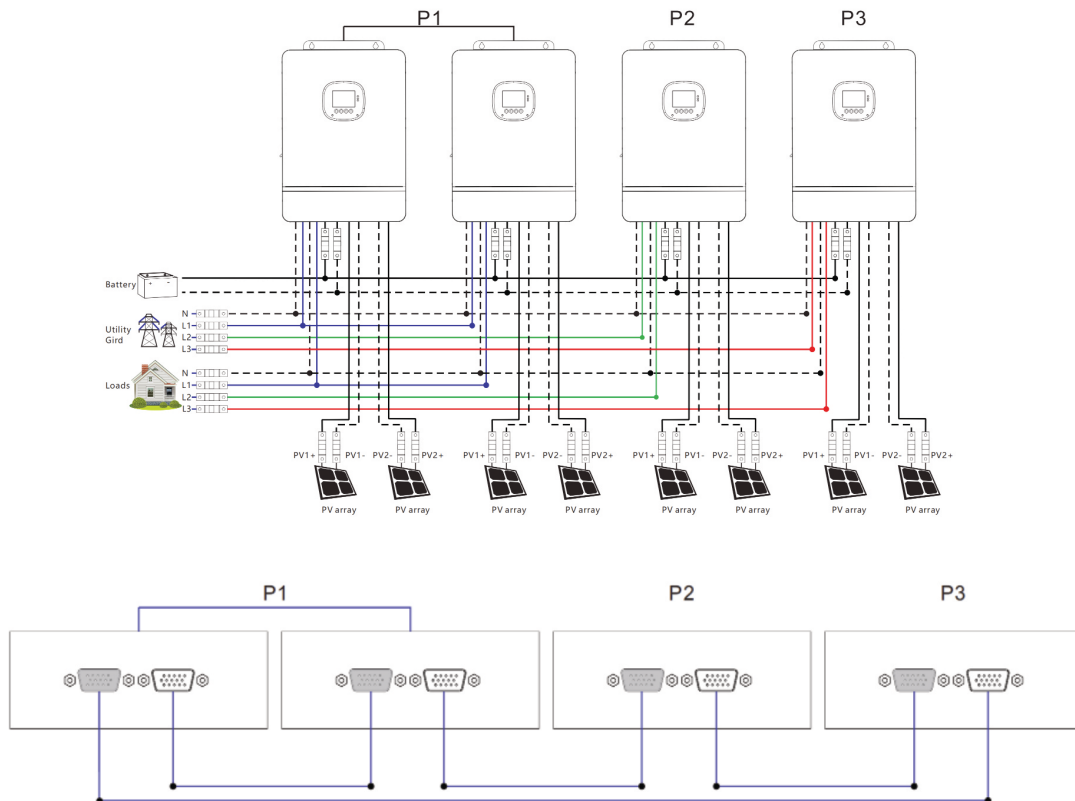

c. Five all-in-one solar charger inverters of the system connected in three phase

2+2+1 system:

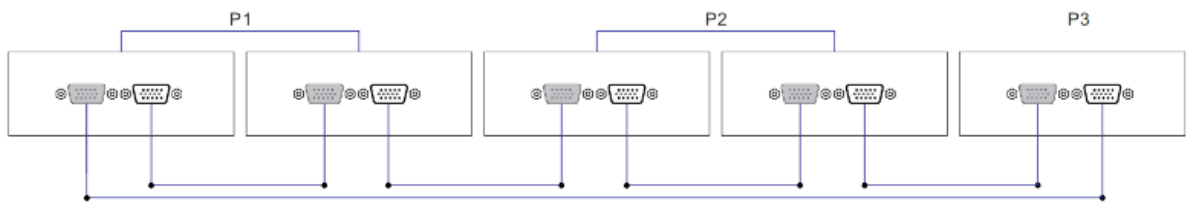
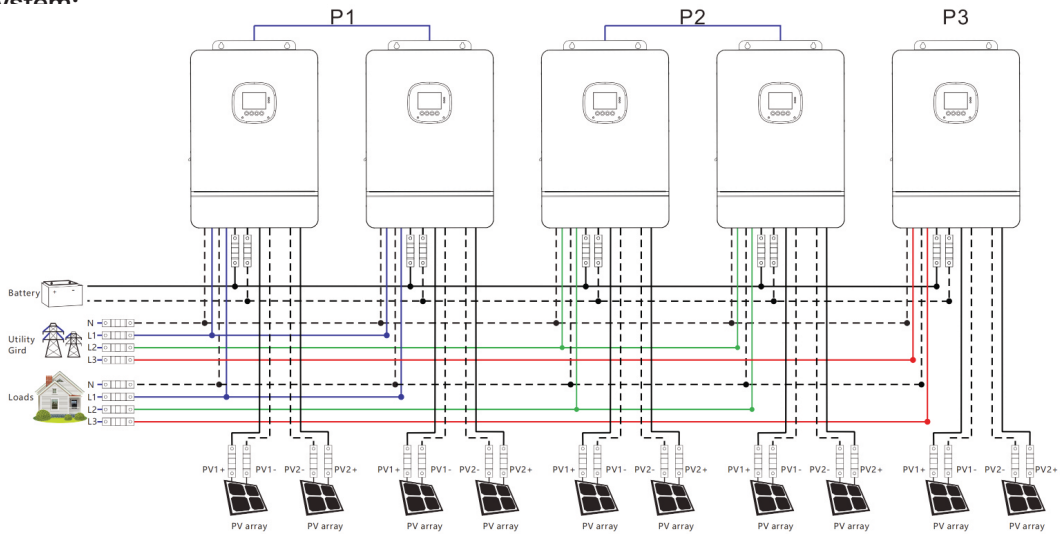

3+1+1 system:

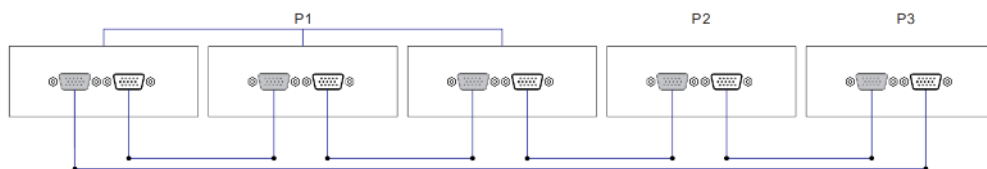
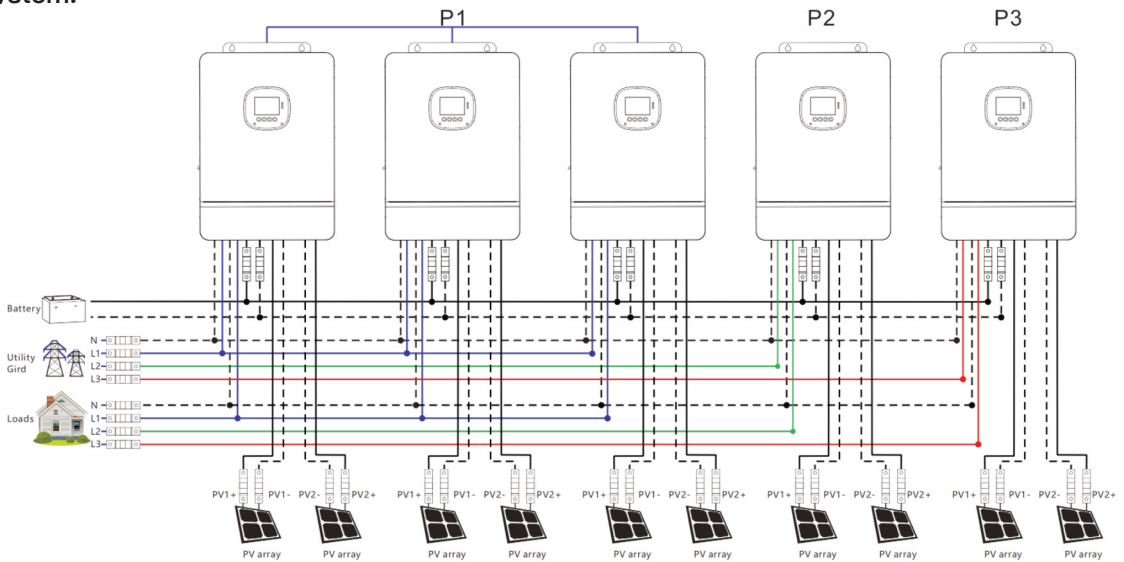

d. Six all-in-one solar charger inverters of the system connected in three phase 2+2+2 system:

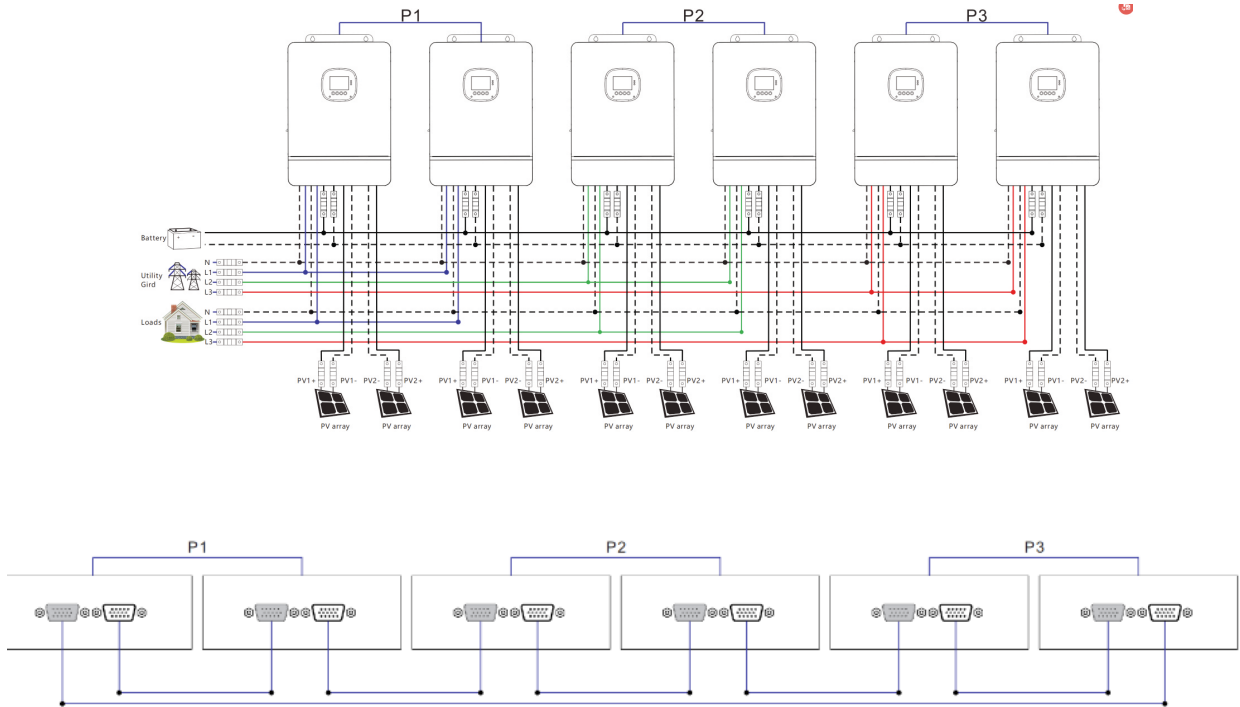

3+2+1 system:

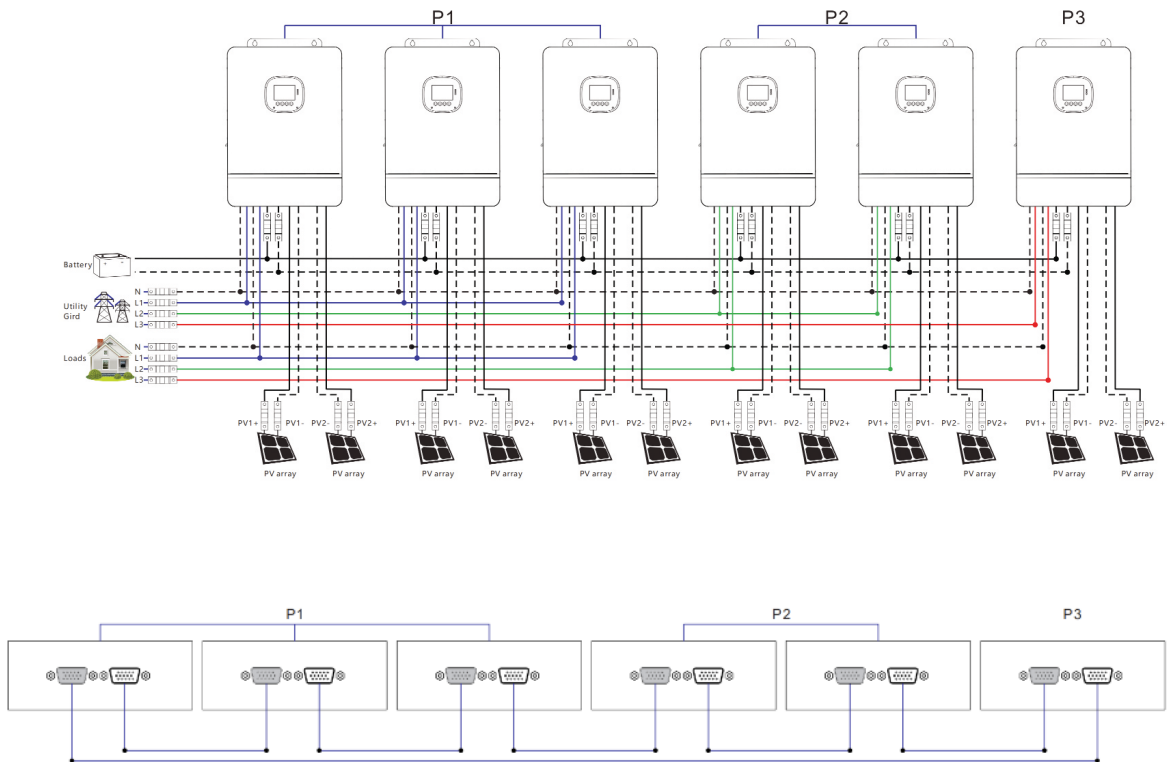

4+1+1 system:

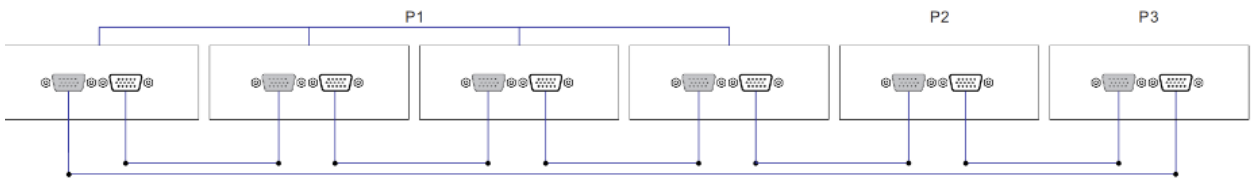
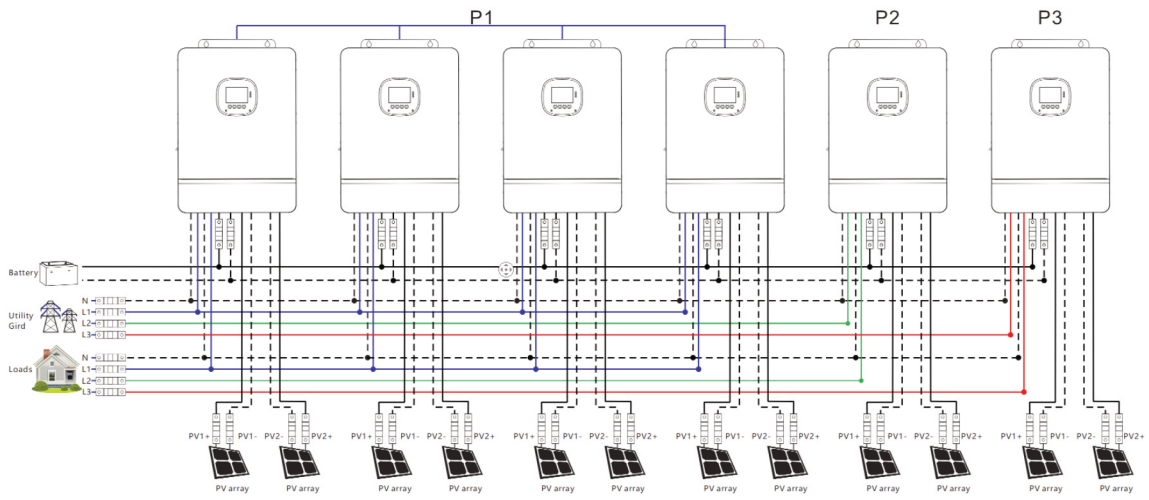

NOTE:

1. Before starting up and running, please check whether the connection was correct to avoid any abnormalities in the system.
2. All wiring must be fixed and reliable to avoid wire drop during use.
3. When the AC output is wired to the load, it shall be properly wired according to the requirements of the electrical load equipment to avoid damage to the load equipment.
4. Settings [38] need to be set consistently or only for the host. When the machine is running, the voltage set by the host shall prevail, and the master will force the rewrite of the other slave machines to keep the same set. Only can be set in the standby mode.
5. Machine factory default for single machine mode, if you use parallel or three-phase function, you need to set the [31] item parameters through the screen. The setting method is: power on one machine at a time, the rest of the machine off, and then set the [31] item parameters according to the site system operation mode. After this machine is set successfully, turn off the machine switch and wait for the machine to be powered down, then set the rest of the machines in turn until all machines are set, and then all machines are powered up again at the same time and enter the working state.

The [31] setting item:

When in single phase parallel connection : setting 【31】 should be set as 【PAL】 .

When in three phase parallel connection, all machines in phase 1 must be set as 【3P1】 , all machines in phase 2 must be set as 【3P2】 all machines in phase 3 must be set as 【3P3】 , at present, the voltage phase difference between P1-P2, P1-P3 and P2-P3 is 120 degrees.

a. When the output voltage set in the setting 【38】 is 230Vac, the line voltage between fire wire L1 in phase 1 and fire wire L2 in phase 2 is $230 \times 1.732 = 398\text{Vac}$, and similarly the line voltage between L1-L3, L2-L3 is 398Vac.

6. After the system runs, the output voltage is measured correctly, and then the load setting is connected.

4. Connection

4.1 Single-phase output

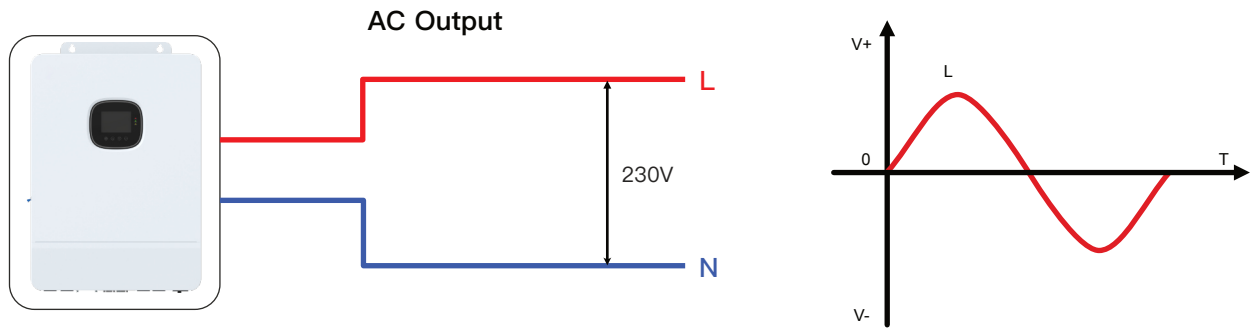

Items	Description
Applicable Model	SPI-8K-SP/SPI-10K-SP
AC Output Voltage Range (L-N)	200~240Vac, 230Vac default

NOTICE

- Users can change the output voltage by setup menu. Please read the chapter 5.2 Setting.
- Output voltage corresponds parameter P8 , the output voltage can be set from 200V to 240V.

Single-phase Mode

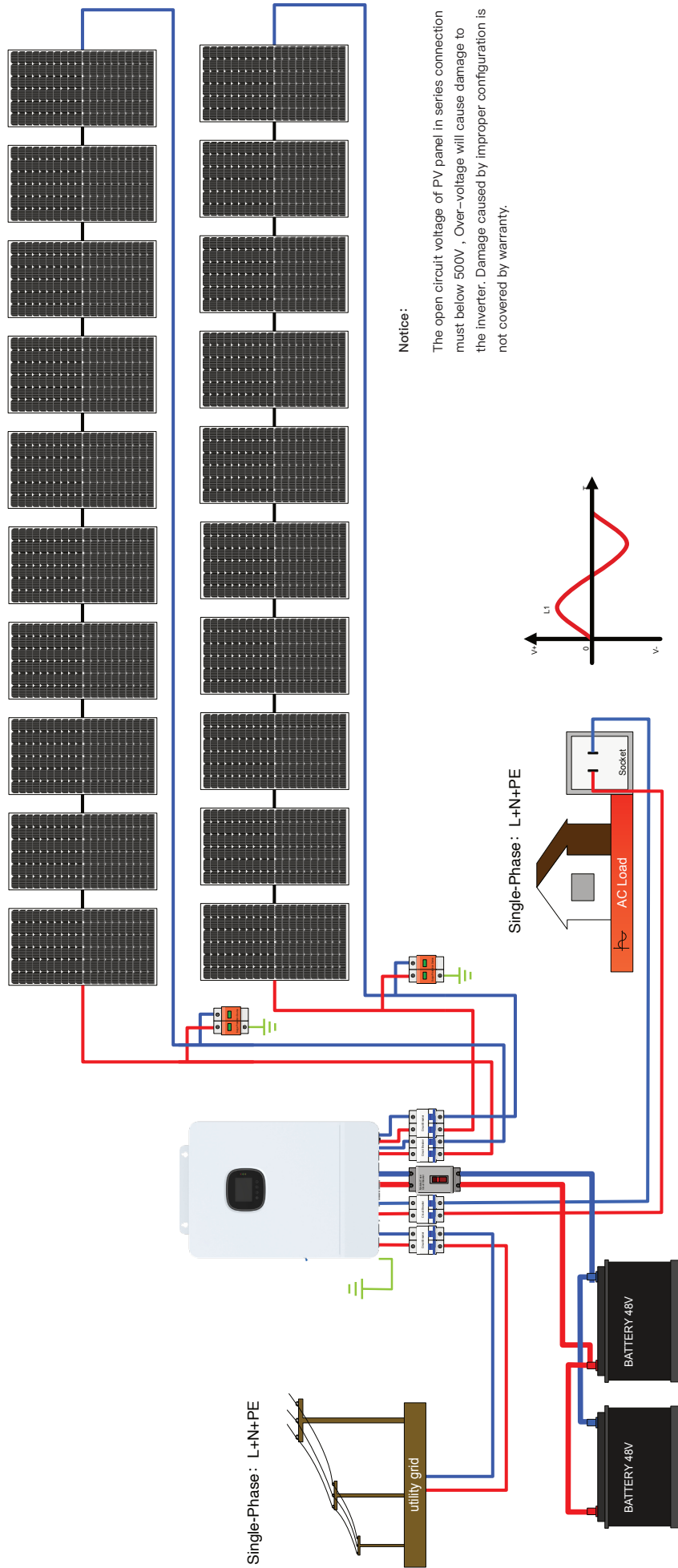

Notice:

The open circuit voltage of PV panel in series connection must below 500V , Over-voltage will cause damage to the inverter. Damage caused by improper configuration is not covered by warranty.

Single-Phase: L+N+PE

Single-Phase: L+N+PE

4.2 Cable & circuit breaker requirement

- PV INPUT**

Model	Cable Diameter	Max.PV Input Current	Circuit Breaker Spec
SPI-8K-SP	5mm ² / 10 AWG	22A	2P-25A
SPI-10K-SP	5mm ² / 10 AWG	22A	2P-25A

- AC INPUT**

Model	Output Mode	Max.Input Current	Cable diameter	Circuit Breaker Spec
SPI-8K-SP	Single-phase	63A (L/N)	13mm ² / 6AWG	2P-63A
SPI-10K-SP	Single-phase	63A (L/N)	13mm ² / 6AWG	2P-63A

- BATTERY**

Model	Cable Diameter	Max.Battery Current	Circuit Breaker Spec
SPI-8K-SP	34mm ² / 2 AWG	180A	2P-200A
SPI-10K-SP	42mm ² / 1 AWG	220A	2P-250A

- AC OUTPUT**

Model	Output Mode	Max.Output Current	Cable diameter	Circuit Breaker Spec
SPI-8K-SP	Single-phase	63A (L/N)	13mm ² / 6AWG	2P-63A
SPI-10K-SP	Single-phase	63A (L/N)	13mm ² / 6AWG	2P-63A

NOTICE

• **PV INPUT、AC INPUT、AC OUTPUT**

1. Use a stripper to remove the 6~8mm insulation of the cable.
2. Fixing a ferrule at the end of the cable. (ferrule needs to be prepared by the user)

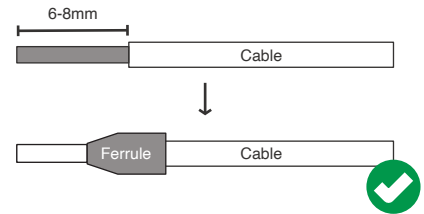

• **BATTERY**

1. Use a stripper to remove the 6~8mm insulation of the cable
2. Fixing cable lugs that supply with the box at the end of the cable.

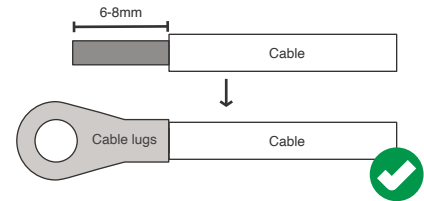

The wire diameter is for reference only. If the distance between the PV array and the inverter or between the inverter and the battery is long, using a thicker wire will reduce the voltage drop and improve the performance of the system.

4.3 AC input & output connection

Connect the fire wire, zero wire and ground wire according to the cables' position and order shown in the diagram below.

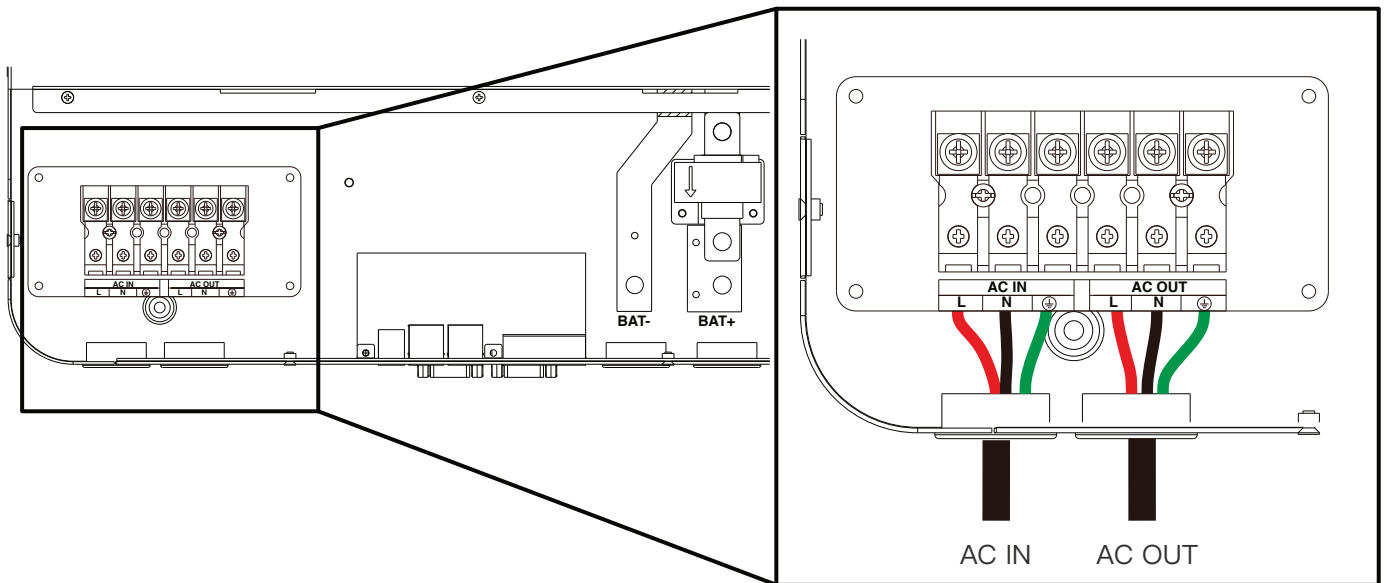

⚠ DANGER

- Before connecting AC inputs and outputs, the circuit breaker must be opened to avoid the risk of electric shock and must not be operated with electricity.
- Please check that the cable used is sufficient for the requirements, too thin, poor quality cables are a serious safety hazard.

4.4 Battery Connection

Connect the positive and negative cable of the battery according to the diagram below.

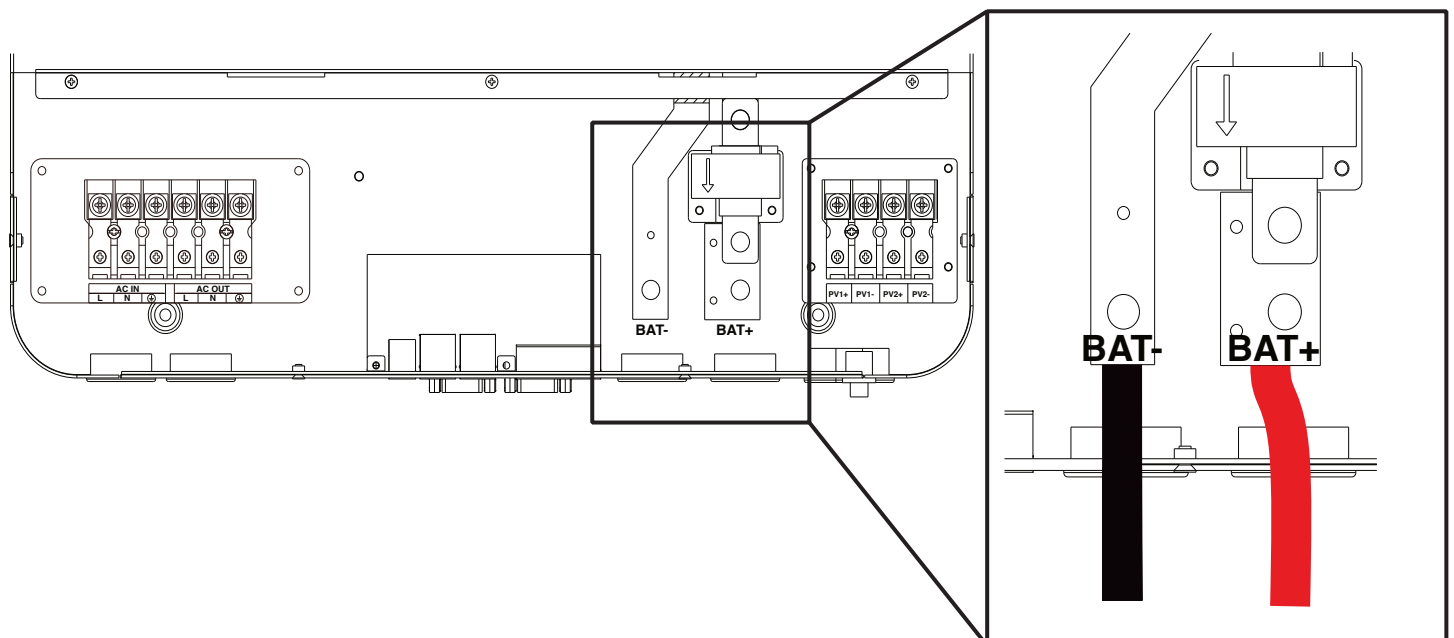

⚠ DANGER

- Before connecting battery, the circuit breaker must be opened to avoid the risk of electric shock and must not be operated with electricity.
- Make sure that the positive and negative terminals of the battery are connected correctly and not reversed, otherwise the inverter may be damaged.
- Please check that the cable used is sufficient for the requirements, too thin, poor quality cables are a serious safety hazard.

4.5 PV connection

Connect the positive and negative wires of the two strings of PV according to the diagram below.

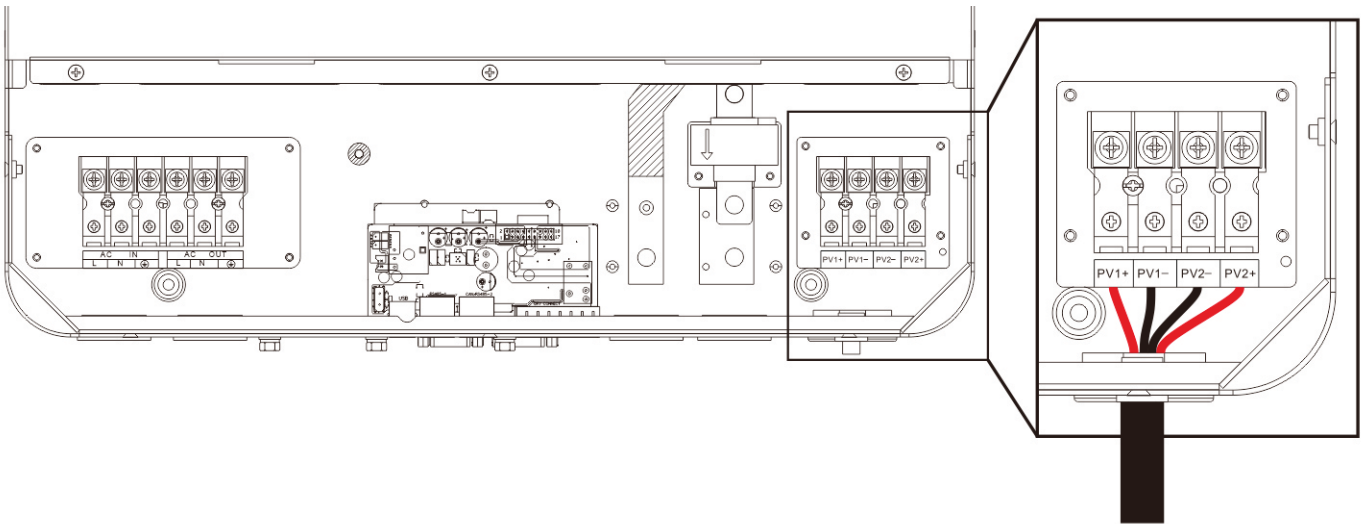

⚠ DANGER

- Before connecting PV, the circuit breaker must be opened to avoid the risk of electric shock and must not be operated with electricity.
- Please make sure that the open circuit voltage of the PV modules in series does not exceed the Max. Open Circuit Voltage of the inverter (In the SPI series, this value is 500V), otherwise the inverter may be damaged.

4.6 Dry contact connection

Use a small screwdriver to push back the direction indicated by the arrow, then insert the communication cable into the dry junction port. (Communication cable diameter 0.2~1.5mm²)

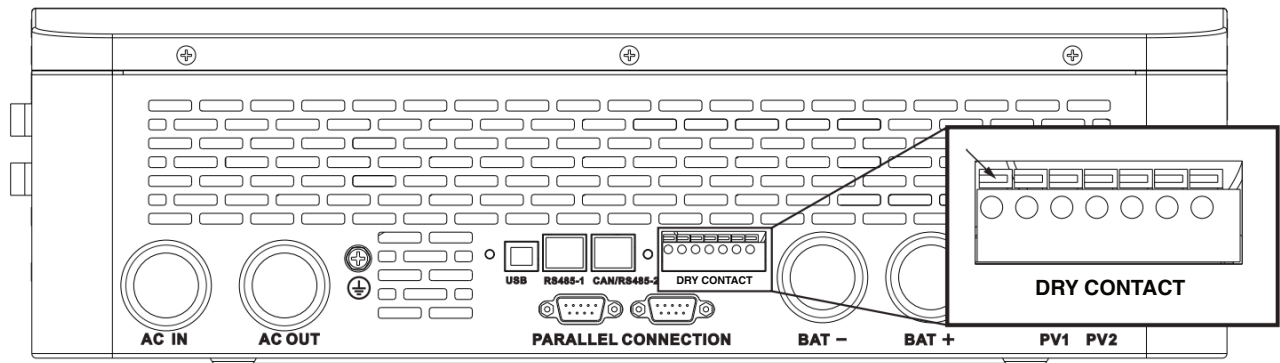

4.7 Grounding connection

Please make sure the grounding terminal connect to the Grounding Bar.

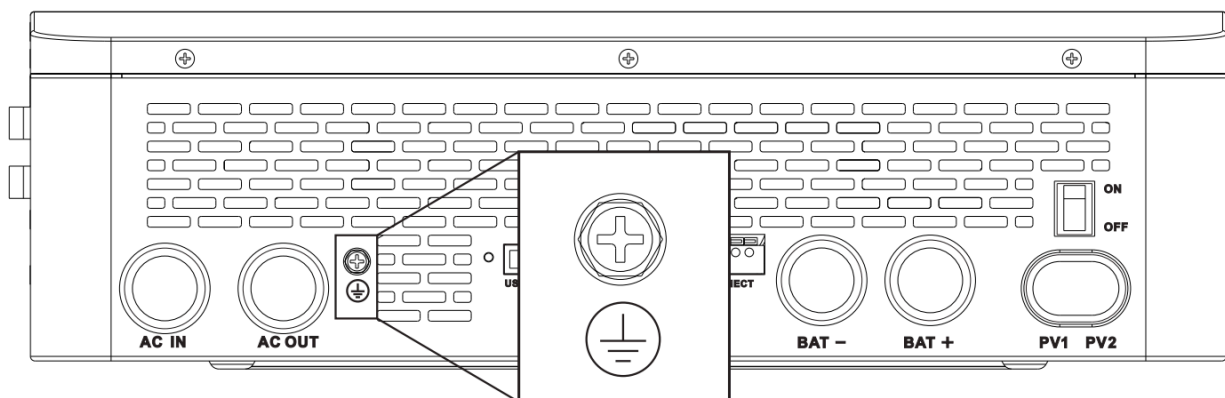

NOTICE

- The grounding cable should have a diameter of not less than 4 mm² and be as close as possible to the grounding point.

4.8 Final assembly

After ensuring that the wiring is reliable and the wire sequence is correct, install the terminal protection cover in place.

4.9 Start up the inverter

- **Step 1:** Close the circuit breaker of the battery.
- **Step 2:** Press the rocker switch on the bottom of inverter, the screen and indicators light up to indicate that the inverter has been activated.
- **Step 3:** Sequential close of the circuit breakers for PV, AC input and AC output.
- **Step 4:** Start the loads one by one in order of power from small to large.



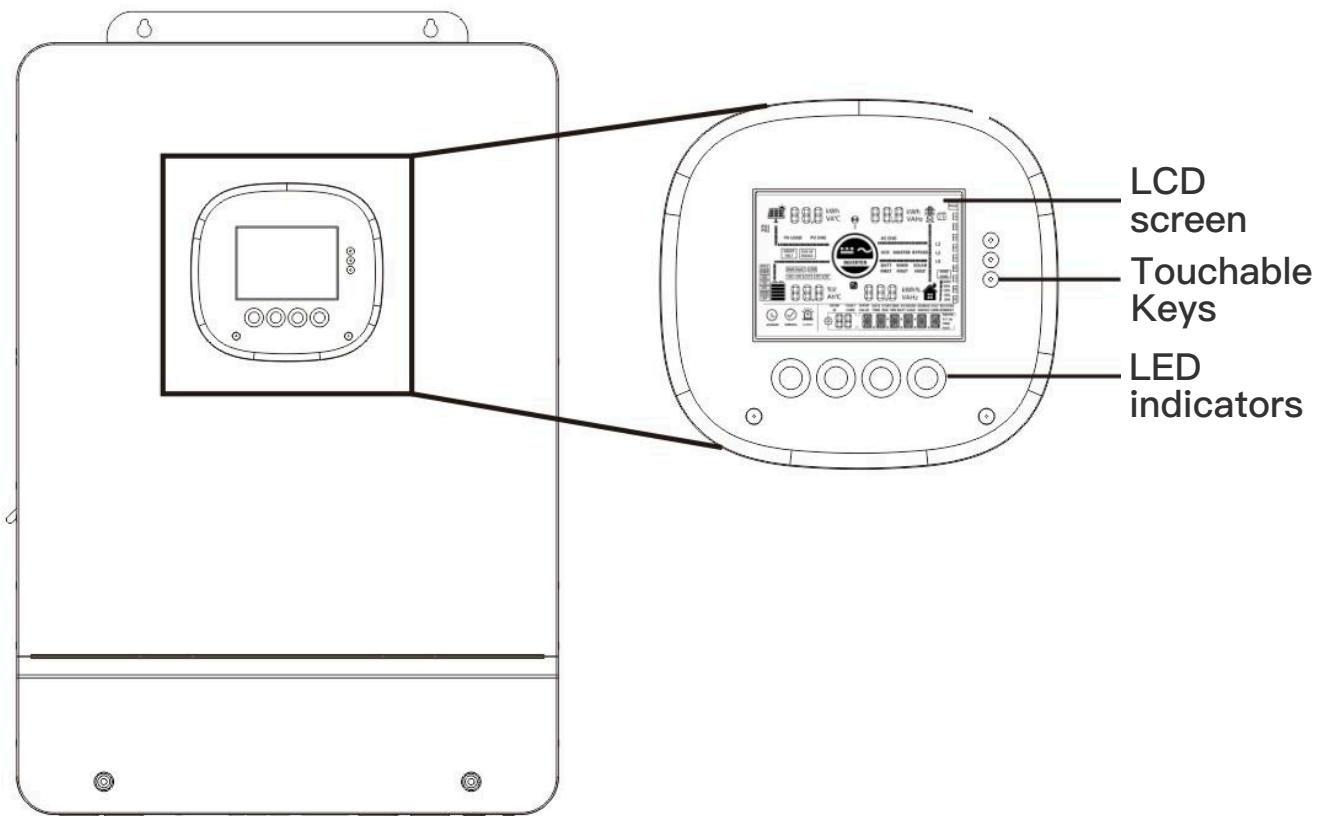

5. Operation

5.1 Operation and display panel

The operation and display panel below includes 1 LCD screen, 3 indicator lights, 4 touchable keys.



• Touchable Keys

Touchable Keys	Description
	To enter/exit the setting menu
	To next selection
	To previous selection
	To confirm/enter the selection in setting menu







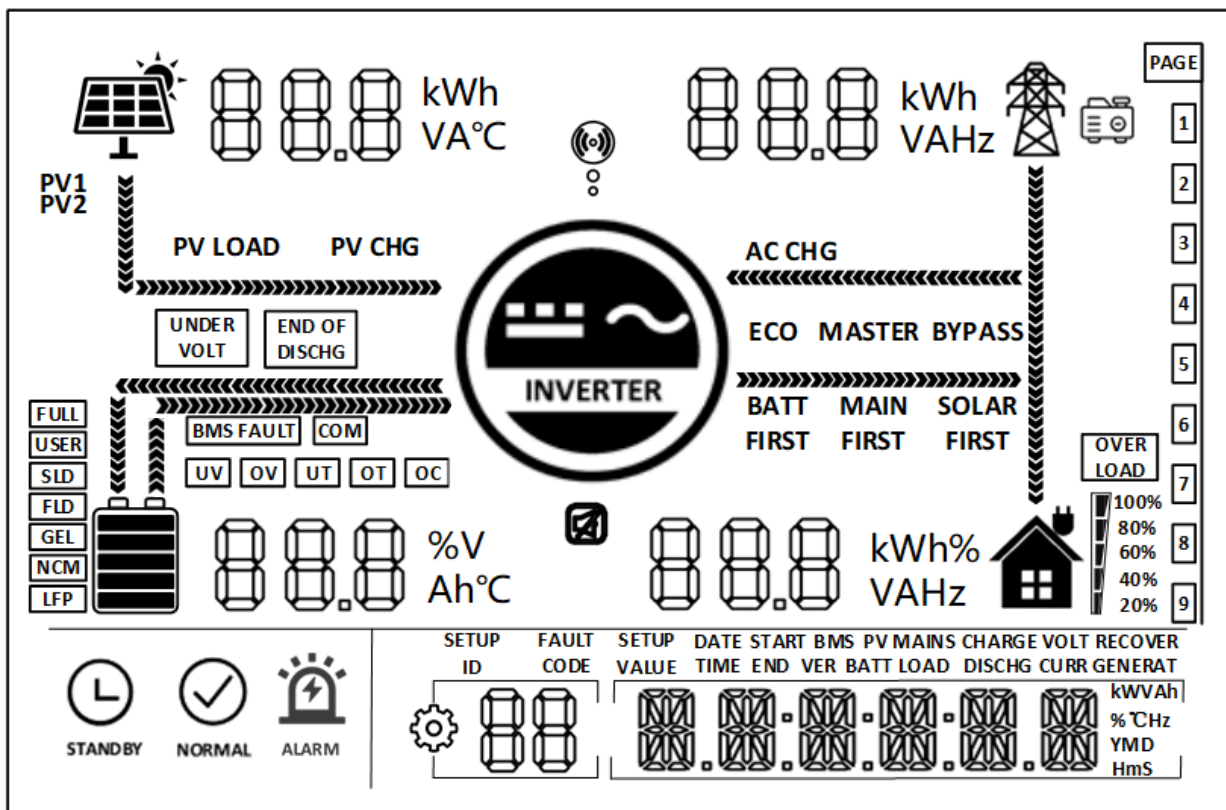



















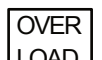



- LED Indicators

Indicators	Color	Description
AC/INV	Green	Continued: utility grid by-pass output
		Flash: inverter output
CHARGE	Yellow	Continued: charging complete
		Flash: charging
FAULT	Red	Flash: error occur

- Display panel



Icon	Description	Icon	Description
	Indicates the PV panel		Indicates the utility grid
	Indicates the battery		Indicates the generator
	Indicates the inverter is working		Indicates the home load
	Indicates the inverter is communicating with data collector		Indicates the buzzer muted
	Indicates the direction of energy flow		

Icon	Description	Icon	Description
 STANDBY	Indicates the inverter is standby	 NORMAL	Indicates the inverter is working normally
 ALARM	Indicates error occur		Indicates setting
	Indicates load power 80%~100%		Indicates battery SOC 80%~100%
	Indicates load power 60%~79%		Indicates battery SOC 60%~79%
	Indicates load power 40%~59%		Indicates battery SOC 40%~59%
	Indicates load power 20%~39%		Indicates battery SOC 20%~39%
	Indicates load power 5%~19%		Indicates battery SOC 5%~19%
	Indicates battery under-voltage		Battery over-discharge
	Indicates over-load		Indicates BMS fault
	Indicates system communication error		Indicates system under-voltage
	Indicates system over-voltage		Indicates system under-temperature
	Indicates system over-temperature		Indicates system over-current
	Indicates battery is full		Indicates user defined battery
	Indicates sealed lead-acid battery		Indicates flooded lead-acid battery
	Indicates gel lead-acid battery		Indicates ternary li-ion battery
	Indicates LFP li-ion battery	ECO	Indicates energy-saving mode
PV LOAD	Indicates PV energy is carrying the load	PV CHG	Indicates PV energy is charging the battery
AC CHG	Indicates AC IN energy is charging the battery	MAIN FIRST	Indicates the inverter output mode is mains power first
BYPASS	Indicates the inverter output mode is bypass	SOLAR FIRST	Indicates the inverter output mode is solar first
BATT FIRST	Indicates the inverter output mode is battery first		

- View real-time data

In the main screen, press the UP / DOWN keys to view the real-time data of the inverter during operation.

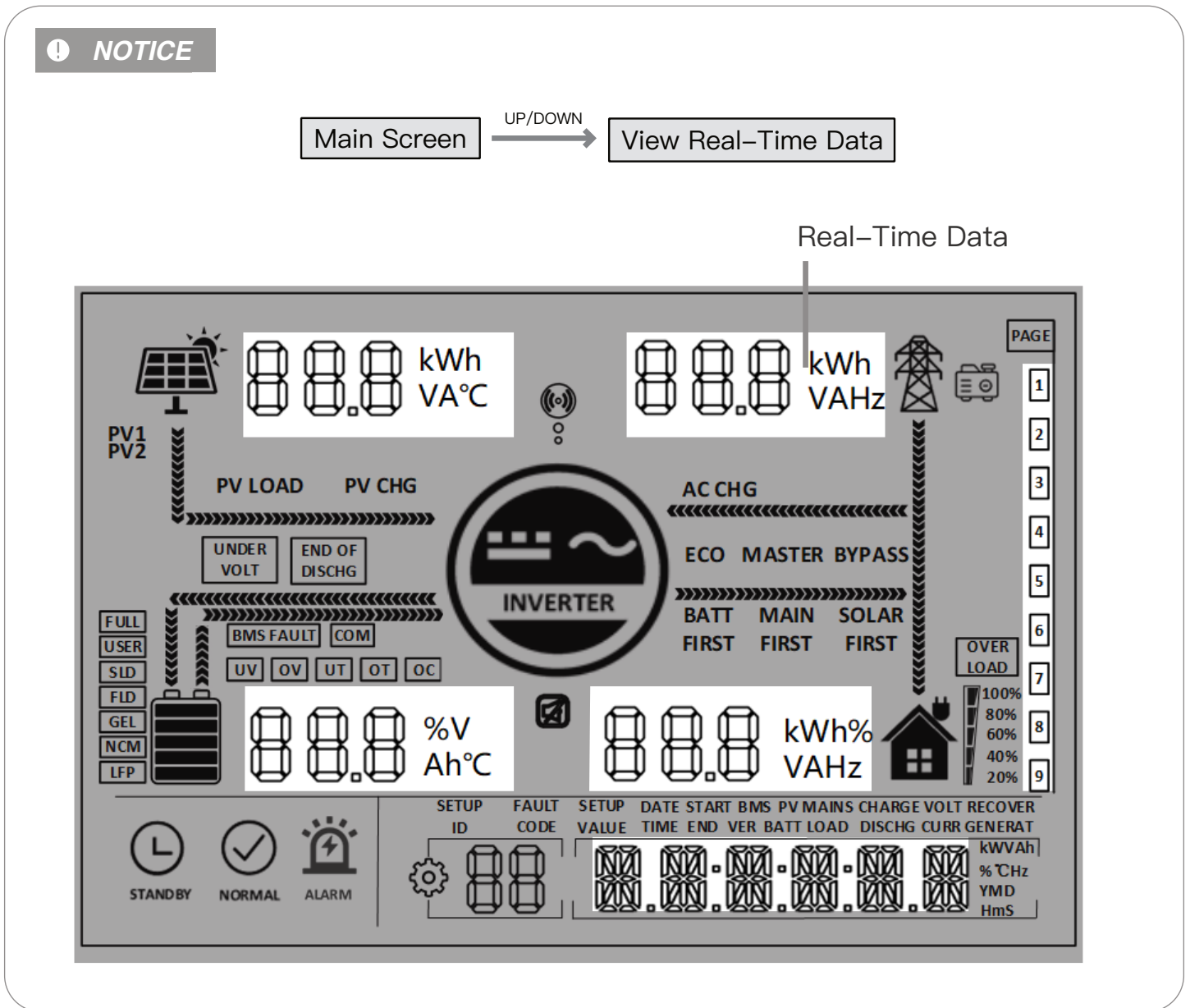

Page	PV side	BAT side	AC IN side	LOAD side	General
1	PV voltage	Batt Voltage	AC in voltage	Single phase voltage	Current Time
2	PV current	Batt Current	AC in current	Single phase Current	Current Date
3	PV power	Batt Voltage	Total AC charging power	Single phase active power	PV Total kWh
4	PV today kWh	Batt Current	Today AC charging kWh	Single phase apparent power	Load Total kWh
5	PV side heat sink temperature	INV Heat Sink Temperature	AC frequency	AC output frequency	RS485 Address
6	PV rated voltage	Batt Rated Voltage	Busbar voltage	AC output rated power	Software Version
7	Max. PV charging current	Max. Batt charging current	Max. AC charging Current	Total AC output active power	Parallel mode display
8	/	/	/	Total AC output apparent power	/

5.2 Setting

NOTICE

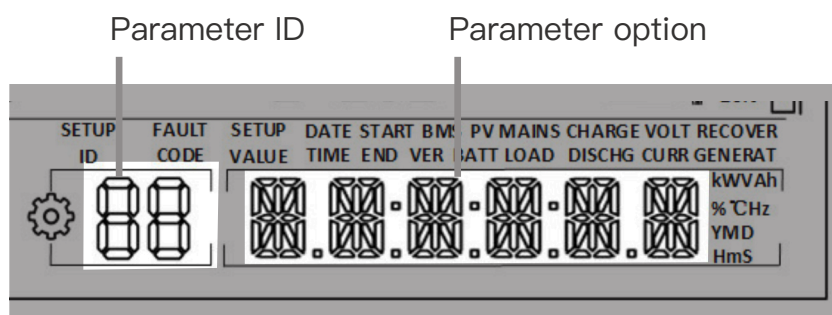
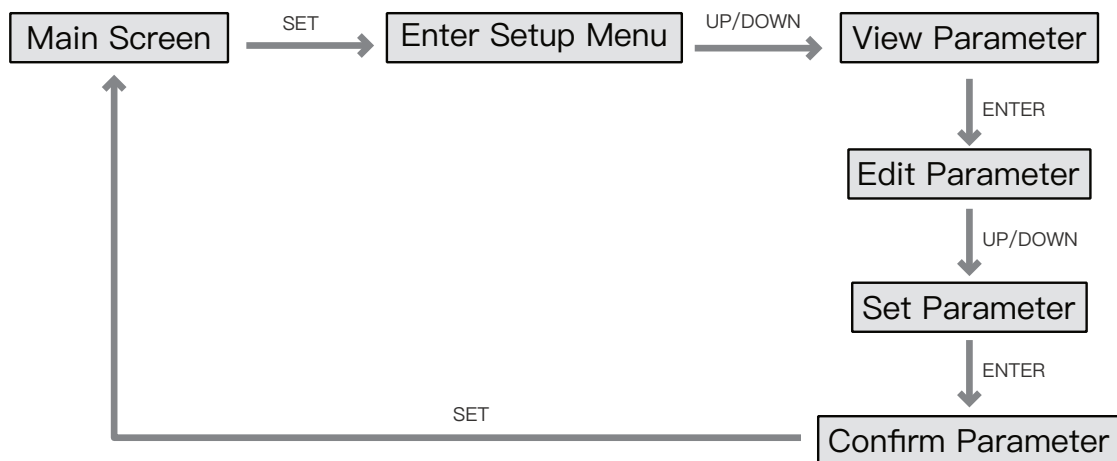

ID	Parameter Meaning	Options	Description
00	Exit	ESC	Exit the setup menu.
01	AC output source priority	UTI <i>default</i>	Utility at first priority, utility and solar provide power to load at the same time when solar is available in both hybrid mode and on-grid mode, battery will provide power to load only when utility power is not available. (When the timed discharge function is used, the battery can be discharged)
		SBU	Inverter at first priority, utility will provide power to load when the battery voltage below parameter [04] value. When the battery voltage is higher than parameter [05] value or when it is full, switching from utility to inverter.
		SOL	Solar at first priority, utility will provide power to load when solar power is not available and the battery voltage below parameter [04] value.
02	AC output frequency	50.0 <i>default</i>	AC output frequency will adaptive utility frequency in bypass mode. Otherwise the output will follow the preset value.
		60.0	

ID	Parameter Meaning	Options	Description
03	AC input voltage range	UPS <i>default</i>	When output range is 220/230V, input voltage range 170~280V.
		RPL	When output range is 220/230V, input voltage range 90~280V, frequency range changes to 40~70 Hz. Can only be set in off-grid mode. Hybrid mode (parameter [34]) automatically changes to ups.
04	Voltage point of battery switch to utility	43.6	When parameter 01 = SBU/SOL, output source will switch to utility from battery when the battery voltage below the preset value. Setting range:40~52V.
05	Voltage point of utility switch to battery	56.8	When parameter 01 = SBU/SOL, output source will switch to battery from utility when the battery voltage above the preset value. Setting range:48~60V.
06	Battery charging mode	SNU <i>default</i>	Solar and utility charging the battery at the same time, solar at the first priority, utility power as a supplement when solar is not sufficient. Solar and utility charging the battery at the same time only in bypass mode, only solar charging can be used when the invert circuit is in operation. Can only be set in off-grid mode. Hybrid mode (parameter [34]) automatically changes to snu.
		CU8	Utility is the first priority in charging, solar charging the battery only when utility is not available.
		CS0	Solar is the first priority in charging, utility charging the battery only when solar is not available.
		OS0	Only solar charging the battery, no utility charging.
07	Battery charging current	60	SPI-8K-SP, setting range:0~180A
			SPI-10K-SP, setting range:0~200A.
08	Battery type	USER	User-defined, user can set all battery parameter.
		SLd	Sealed lead-acid battery.
		FLd	Flooded lead-acid battery.
		GEL <i>default</i>	Gel lead-acid battery.
		L14/L15/L16	LFP li-ion battery, corresponding to batteries 14, 15, 16 series.
N13/N14	Ternary li-ion battery, corresponding to batteries 13, 14 series.		
09	Battery boost charging voltage	57.6	Setting range:48V~58.4V, increment of each click is 0.4V, parameter can be set only when battery type is USER and L14/15/16, N13/14.
10	Battery boost charging delay time	120	This refers to the duration of charging time when the voltage reaches the voltage set in parameter 09 during constant voltage charging, the setting range is 5min~900min, in steps of 5 minutes.
11	Battery float charging voltage	55.2	Setting range: 48V~58.4V, in steps of 0.4V. This parameter cannot be set after successful BMS communication.

ID	Parameter Meaning	Options	Description
12	Battery over-discharge voltage (delay off)	42	When the battery voltage falls below this voltage point and item 13 value is reached, the inverter output will be switched off. Setting range: 40V~48V, in steps of 0.4V.
13	Battery over-discharge voltage delay time	5	When the battery voltage is lower than item 12 of the parameter and the delay time set in this parameter is triggered, the inverter output is switched off, the setting range is 5S~50S, in steps of 5S.
14	Battery under-voltage alarm	44	When the battery voltage falls below this voltage point, alarm will be displayed on the screen and indicator. Setting range: 40V~52V, in steps of 0.4V.
15	Battery under-voltage limit voltage	40	When the battery voltage falls below this voltage point, the inverter output is switched off immediately. Setting range is 40V~52V, in steps of 0.4V, parameter can be set only when battery type is USER and L14/15/16, N13/14.
16	Battery equalization charging	dis <i>default</i>	Disable equalization charging.
		ENA	Enable equalization charging, parameter can be set only when battery type is FLd/SLd/USER.
17	Battery equalization charging voltage	58	Setting range: 48V~58V, in steps of 0.4V, parameter can be set only when battery type is FLd\SLd\USER.
18	Battery equalization charging duration	120	Setting range: 5min~900min, in steps of 5mins, parameter can be set only when battery type is FLd\SLd\USER.
19	Battery equalization charging delay time	120	Setting range: 5min~900min, in steps of 5mins, parameter can be set only when battery type is FLd\SLd\USER.
20	Battery equalization charging interval	30	Setting range: 0~30 days, in steps of 1day, parameter can be set only when battery type is FLd\SLd\USER.
21	Battery equalization charging stop-start	dis <i>default</i>	Start equalization charging immediately.
		ENA	Stop equalization charging immediately.
22	Power saving mode (Supports stand-alone mode only)	dis <i>default</i>	Disable power saving mode.
		ENA	Enable power saving mode, When the load power below 50W, the inverter output will switch off after a 5mins delay . When the load is higher than 50W, the inverter automatic restart.
23	Over-load restart	dis	When overload occurs and the output is switched off, the machine will not restart.
		ENA <i>default</i>	When overload occurs and the output is switched off, the machine will restart after a delay of 3 mins. After it reaches 5 cumulative time, the machine will not restart automatically.

ID	Parameter Meaning	Options	Description
24	Over-temperature restart	DIS	Disable over-temperature restart. When over temperature occurs and the output is switched off, the machine will not restart.
		ENA <i>default</i>	Enable over-temperature restart. When overload occurs and the output is switched off, the machine will restart when the temperature drops.
25	Buzzer alarm	DIS	Disable buzzer alarm.
		ENA <i>default</i>	Enable buzzer alarm.
26	Power source switching reminder	DIS	Disable reminder when the status of the input power source changes.
		ENA <i>default</i>	Enable reminder when the status of the input power source changes.
27	Inverter overload switch to bypass	DIS	Disable switch to the bypass automatically when the inverter is overload.
		ENA <i>default</i>	Enable switch to the bypass automatically when the inverter is overload.
28	Max. utility charging current	60	SPI-8K-SP, setting range: 0~100A.
			SPI-10K-SP, setting range: 0~120A.
30	RS485 address	1d: 1	RS485 address setting range: 1~254. Parallel mode: 1~6.
31	AC output mode (Settable only in standby mode)	[31] S1S <i>default</i>	Settings for stand-alone use.
		[31] PAR	Settings for single-phase parallel use.
		[31] 3P1/3P2/3P3	Settings for three-phase parallel use.
			All machines in phase 1 must be set as [3P1] , all machines in phase 2 must be set as [3P2] , all machines in phase 3 must be set as [3P3] . When the output voltage set in the setting [38] is 230Vac: At present, the voltage phase difference between P1-P2, P1-P3 and P2-P3 is 120 degrees. The line voltage between fire wire L1 in phase 1 and fire wire L2 in phase 2 is $230 \times 1.732 = 398\text{Vac}$, and similarly the line voltage between L1-L3, L2-L3 is 398Vac. The line voltage between L1-N, L2-N, L3-N is 230Vac.
32	RS485 communication	SLA <i>default</i>	Enabling PC and remote monitoring protocols.
		485	Enabling BMS communication based on RS485.
		CAN	Enabling BMS communication based on CAN.
33	BMS communication		When item 32 is set to 485 or CAN, the corresponding communication protocol must be selected in item 33.
			PAC=PACE, RDA=RITAR, AOG=ALLGRAND, OLT=OLITER, HWD=SUNWODA, DAQ=DYNESS, WOW=SRNE, PYL=PYLONTECH, UOL=VILION

ID	Parameter Meaning	Options	Description
34	On-grid and mixed load function	dis <i>default</i>	Disable this function.
		ON GRd	On-grid function, Solar is charged first and any surplus power after the load demand is met is fed back to the grid. (Item 01 is set to UTI, item 03 is set to UPS, item 06 is set to SNU)
		MIX LOD	Mixed load mode, solar is used in priority to charge the battery and any excess energy is used to power the load when available. With backflow preventer function, solar power is not fed back to the grid. (Item 01 is set to UTI, item 03 is set to UPS, item 06 is set to SNU)
35	Battery under voltage recover point	52	When the battery is under-voltage, the battery voltage needs to be greater than this setting to restore the battery inverter AC output. Setting range: 44V~54.4V.
37	Battery full recharge voltage point	52	Inverter stops charging when the battery is full. Inverter resumes charging when the battery voltage below this value. Setting range: 44V~54V.
38	AC output voltage	220	Setting range: 200/208/220/230/240Vac
39	Charge current limit method (when BMS is enabled)	LC SET	Max. battery charging current not greater than the value of setting [07]
		LC BMS <i>default</i>	Max. battery charging current not greater than the limit value of BMS
		LC INV	Max. battery charging current not greater than the logic judgements value of the inverter
40	1st slot start charging	00:00:00	Setting range: 00:00:00-23:59:00
41	1st slot end charging	00:00:00	Setting range: 00:00:00-23:59:00
42	2nd slot start charging	00:00:00	Setting range: 00:00:00-23:59:00
43	2nd slot end charging	00:00:00	Setting range: 00:00:00-23:59:00
44	3rd slot start charging	00:00:00	Setting range: 00:00:00-23:59:00
45	3rd slot end charging	00:00:00	Setting range: 00:00:00-23:59:00
46	Time slot charging function	dis <i>default</i>	Disable this function.
		ENR	Enable this function, AC output source mode will switch to SBU, utility charging the battery and carry load only in charging time slot which user set or the battery is under voltage. If time slot discharging function is also enabled, AC output source mode will switch to UTI, utility charging the battery only in charging time slot which user set, and switch to battery charging in discharging time slot or utility power failure. (pure off-grid mode only)
47	1st slot start discharging	00:00:00	Setting range: 00:00:00-23:59:00
48	1st slot end discharging	00:00:00	Setting range: 00:00:00-23:59:00
49	2nd slot start discharging	00:00:00	Setting range: 00:00:00-23:59:00
50	2nd slot end discharging	00:00:00	Setting range: 00:00:00-23:59:00
51	3rd slot start discharging	00:00:00	Setting range: 00:00:00-23:59:00

ID	Parameter Meaning	Options	Description
52	3rd slot end discharging	DIS <i>default</i>	Setting range: 00:00:00–23:59:00
53	Time slot discharging function	ENA	Disable this function.
			Enable this function, AC output source mode will switch to UTI , battery discharging only in discharging time slot which user set or utility is not available.
54	Local date	00:00:00	YY/MM/DD. Setting range: 00:01:01–99:12:31
55	Local time	00:00:00	Setting range: 00:00:00–23:59:59
57	Stop charging current	2	Charging stops when the charging current is less than the set value. (unit:A)
58	Discharging alarm SOC	15	Triggers an alarm when the battery SOC is less than the set value. (unit:%)
59	Discharging cutoff SOC	5	Stops discharging when the battery SOC is less than the set value. (unit:%)
60	Charging cutoff SOC	100	Stops charging when the battery SOC is higher than the set value. (unit:%)
61	Switching to utility SOC	10	Switch to utility power when the battery SOC is less than this setting. (unit:%)
62	Switching to inverter SOC	100 <i>default</i>	Switches to inverter output mode when SOC is higher than this setting. (unit:%)
63	N-PE bonding automatic switching function	DIS <i>default</i>	Prohibit automatic switching of N-PE bonding.
			Allow automatic switching of N-PE bonding.
71	PV energy priority	CHG	PV energy gives priority to battery charging, then on-grid charging.
			100

5.3 AC output mode

The AC output mode corresponds to parameter setting item 01 and 34, which allows the user to set the AC output power source manually.

- **Utility Priority Output 01 UT1 (default)**

Utility at first priority, utility and solar provide power to load at the same time when solar is available, battery will provide power to load only when utility power is not available. (Priority: utility>solar>battery)

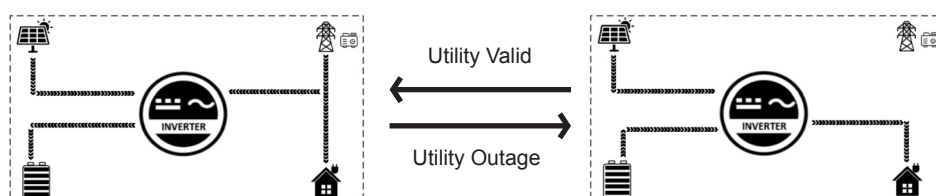

- **Solar and Utility Hybrid Output 34 MIX LOD**

In UT1 mode, when not connected to the battery or when the battery is full, the solar and the utility supply power to the load at the same time. (Priority: solar>utility>battery)

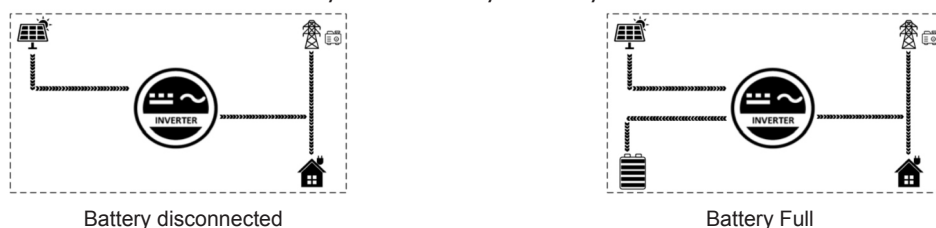

- **Solar Priority Output 01 SOL**

Solar provides power to the loads as first priority. If solar is not available, the utility grid will provide power to the loads. This mode maximizes solar energy while maintaining battery power and is suitable for areas with relatively stable power grids. (Priority: solar>utility>battery)

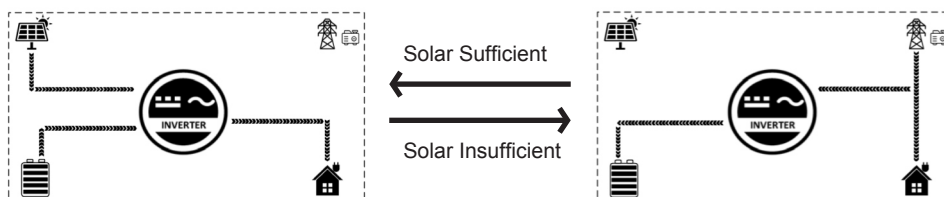

- **Inverter Priority Output 01 SB1**

Solar provides power to the loads as first priority. If solar is not sufficient or not available, the battery will be used as a supplement to provide power to the loads. When the battery voltage reaches the value of parameter 04 (Voltage point of battery switch to utility) will switch to utility to provide power to the load. This model makes maximum use of DC energy and is used in areas where the grid is stable. (Priority: solar>battery>utility)

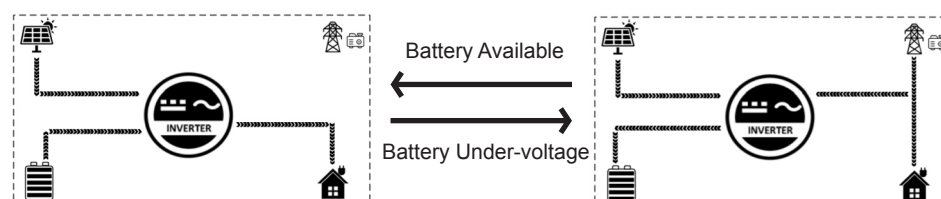

5.4 Battery charging mode

The charging mode corresponds to parameter setting item 06, which allows the user to set the charging mode manually.

- **Hybrid Charging 5111 (default)**

Solar and utility charging the battery at the same time, solar at the first priority, utility power as a supplement when solar power is not sufficient. This is the fastest way to charge and is suitable for areas with low power supply, providing customers with sufficient back-up power.(Source priority: solar>utility)

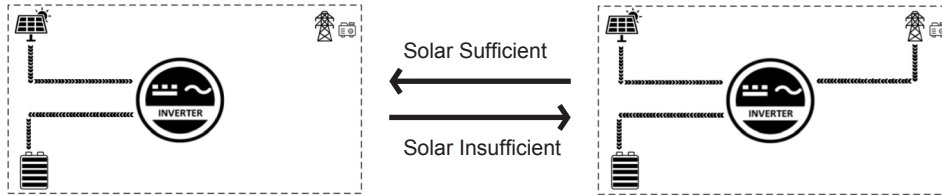

- **Utility Priority Charging 0111**

The utility power gives priority to charging the battery, and PV charging is only activated when the utility power is not available.(Source priority: utility>solar)

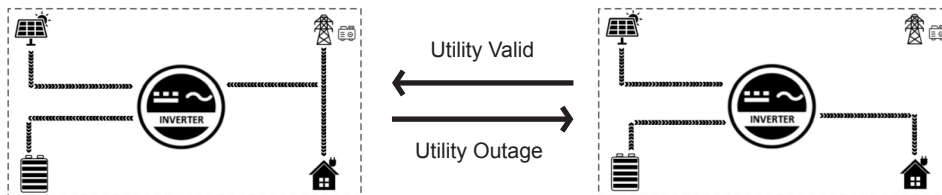

- **Solar Priority Charging 050**

Solar priority charging, with utility charging only activated when the solar fails. By making full use of solar power during the day and switching to utility charging at night, battery power can be maintained and is suitable for applications in areas where the grid is relatively stable and electricity prices are more expensive.(Source priority: solar>utility)

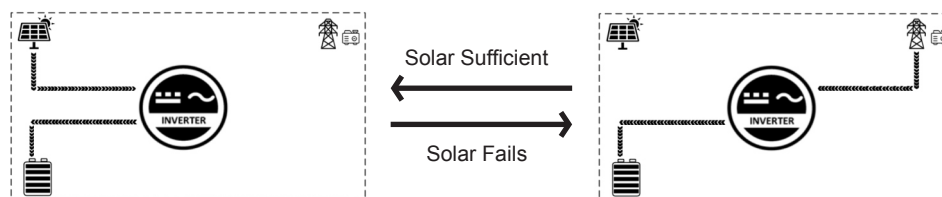

- **Only Solar Charging 050**

Solar charging only, no mains charging is activated. This is the most energy-efficient method, with all the battery power coming from solar energy, and is usually used in areas with good radiation conditions.

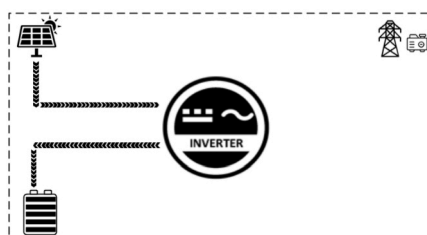

OFF-grid and on-grid mode settings

Mode	Setting	Options	Meaning	Priority	Features
Output modes	01	UTI	Utility priority	utility-solar-battery	This mode maximizes access to available power while maintaining battery power for emergency storage and is suitable for areas with unstable power supplies.
		SOL	Solar priority	solar-utility-battery	This mode maximizes the use of solar power while maintaining battery power as emergency energy storage.
		SBU	Battery priority	solar-battery-utility	This model maximizes the use of DC energy and reduces the cost of electricity, and is suitable for areas where electricity is expensive but stable.
Charging modes	06	SNU	Utility and solar hybrid charging	solar-hybrid-utility	Fastest charging.
		CUB	Utility priority charging	utility-solar	Solar charging is only activated when utility power is not available.
		CSO	Solar priority charging	solar-utility	Only when solar is not available, the utility is activated, which is suitable for areas with a stable grid and expensive electricity prices.
		OSO	Only solar charging	solar	Solar charging only, no utility charging.

Hybrid energy storage application

Mode	Setting	Options	Meaning	Priority	Features
Output modes	34	DIS	Means that the hybrid energy storage application is switched off and the system switches to off-grid applications by default.		
		ON GRD	On-grid	The priority of electricity use can be set in item 46, 53 and 71.	Feeds excess electricity or battery storage back to the grid to help customers generate revenue.
		MIX LOD	Hybrid		Backflow preventer, mixed utility and solar, supporting battery-free use, helping customers to reduce electricity costs.
Time-slot mains charging, with load function.	46	DIS	With this function disabled, the mains does not charge the battery.		
		ENA	Enable time-slot mains charging, with load function	When this function is enabled, the user can set a time period from 40 to 45 items. During this period, if solar power is available, priority will be given to using solar power for charging; when solar power is insufficient, utility power will be used for mixed charging, and when there is no solar power, utility power will be used for charging.	Can take advantage of peak and valley tariffs to store solar electricity and valley electricity in storage batteries.
Time-slot battery discharging function.	53	DIS	With this function disabled, battery storage does not feed back into the grid or carry a load.		
		ENA	Enable time-slot battery discharging function	When this function is enabled, the user can set a time period in items 47 to 52. During this period, if solar power is not sufficient to carry the load or is not sufficient to on-grid at full power, battery power is allowed to be used to carry the load or on-grid.	Can take advantage of peak and valley tariffs to reduce utility use at peak prices or to feed battery storage back into the grid for higher on-grid benefits.
Solar power priority	71	CHG	Solar priority charging	If this option is selected, solar priority charging, and when the battery is fully charged, the residual power can be on-grid.	Battery power can be maintained as emergency storage, and the remaining solar power can be on-grid or carried.
		LOD	Solar power priority on-grid	If this option is selected, solar power will feed back to the grid as a priority and, if sufficient, the excess power is used to recharge the batteries.	No battery storage. Helping users get more out of their electricity generation.

5.5 Time-slot charging/discharging function

The SPI series is equipped with a time-slot charging and discharging function, which allows users to set different charging and discharging periods according to the local peak and valley tariffs, so that the utility power and PV energy can be used rationally.

When mains electricity is expensive, the battery inverter is used to carry the load; when the mains electricity is cheap, the mains electricity is used to carry the load and charge, which can help customers to save electricity costs to the greatest extent.

The user can turn on/off the time-slot charging/discharging function in setup menu parameter 46 and 53. And set charging and discharging slot in parameter 40-45, 47-52. Below are examples for users to understand the function.

NOTICE

Before using this function for the first time, please set the local time in parameter items 54, 55, then the user can set the corresponding time slot according to the local peak and valley tariff charges.

Peak-Valley Electricity Tariff

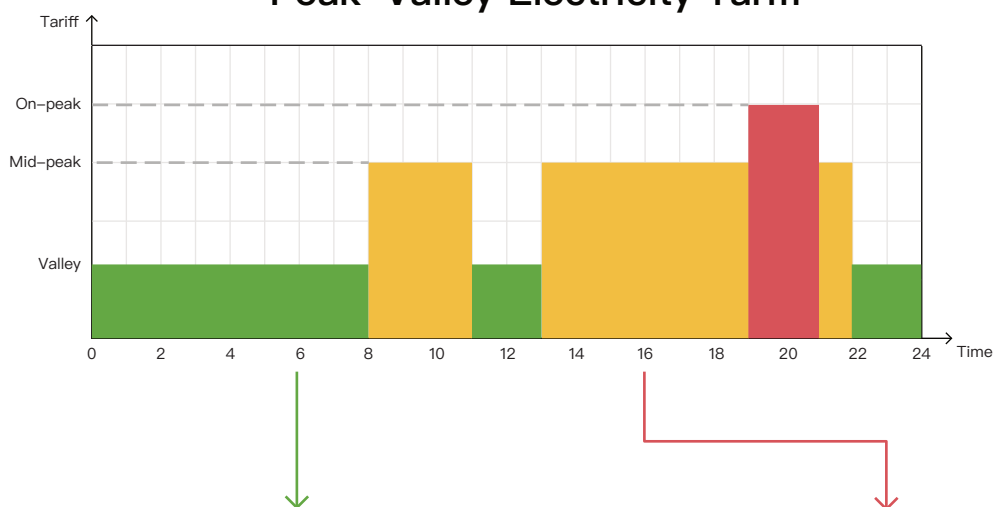

Time-slot Utility Charging/Carrying Function

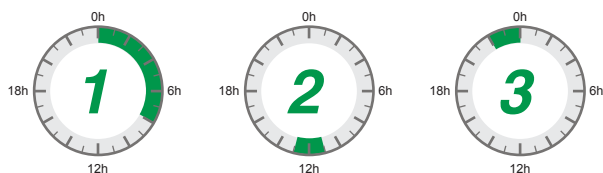

With 3 definable periods, the user can freely set the mains charging/carrying time within the range of 00:00 to 23:59. During the time period set by the user, if PV energy is available, PV energy will be used first, and if PV energy is not available or insufficient, utility energy will be used as a supplement.

Time-slot Battery Discharging Function



With 3 definable time periods, users can freely set the battery discharge time within the range of 00:00 to 23:59. During the time period set by the user, the inverter will give priority to the battery inverter to carry the load, and if the battery power is insufficient, the inverter will automatically switch to mains power to ensure stable operation of the load.

5.6 Battery parameter

- Lead-acid battery

Parameter/Battery type	Sealed	Gel	Flooded	User-defined
	SLd	SEL	FLd	USER
Over-voltage cut-off voltage	60V	60V	60V	60V
Equalization charging voltage	58V	56.8V	58V	40~60V settable
Boost charging voltage	57.6V	56.8V	57.6V	40~60V settable
Float charging voltage	55.2V	55.2V	55.2V	40~60V settable
Under-voltage alarm voltage	44V	44V	44V	40~60V settable
Under-voltage cut-off voltage	42V	42V	42V	40~60V settable
Discharging limit voltage	40V	40V	40V	40~60V settable
Over-discharge delay time	5s	5s	5s	1~30s settable
Equalization charging duration	120min	-	120min	0~600min settable
Equalization charging interval	30d	-	30d	0~250d settable
Boost charging duration	120min	120min	120min	10~600m settable

NOTICE

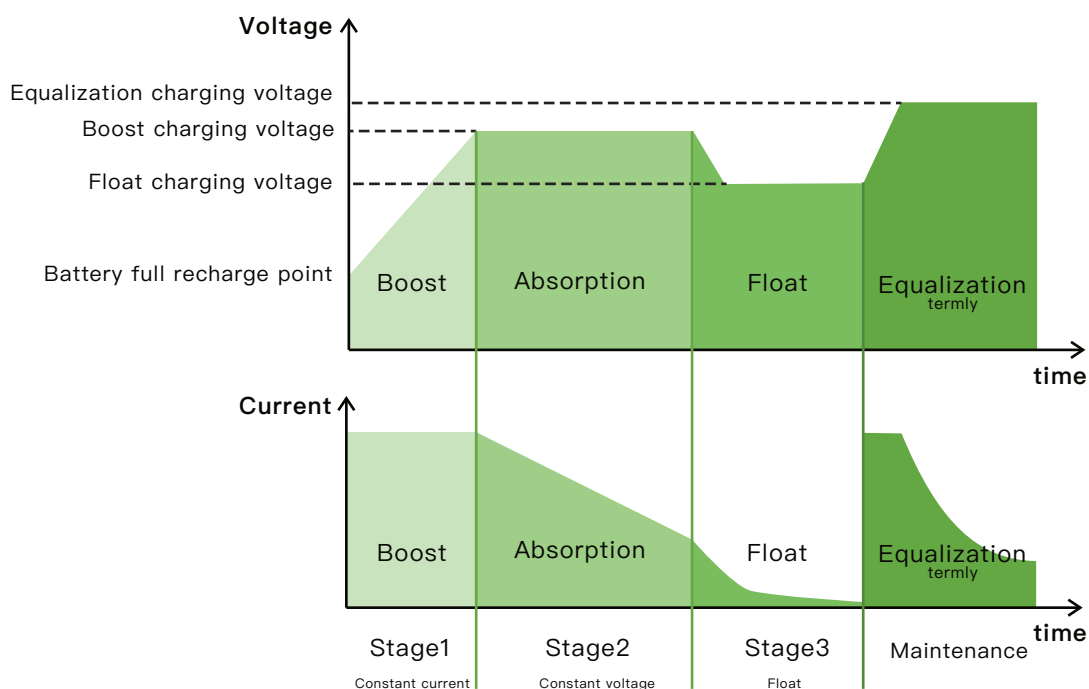

• Li-ion battery

Parameter/Battery type	Ternary		LFP			User-defined
	Ni3	Ni4	Li5	Li5	Li4	USER
Over-voltage cut-off voltage	60V	60V	60V	60V	60V	60V
Equalization charging voltage	-	-	-	-	-	40~60V settable
Boost charging voltage	53.2V	57.6V	56.8V	53.2V	49.2V	40~60V settable
Float charging voltage	53.2V	57.6V	56.8V	53.2V	49.2V	40~60V settable
Under-voltage alarm voltage	43.6V	46.8V	49.6V	46.4V	43.2V	40~60V settable
Under-voltage cut-off voltage	38.8V	42V	48.8V	45.6V	42V	40~60V settable
Discharging limit voltage	36.4V	39.2V	46.4V	43.6V	40.8V	40~60V settable
Over-discharge delay time	30s	30s	30s	30s	30s	1~30s settable
Equalization charging duration	-	-	-	-	-	0~600min settable
Equalization charging interval	-	-	-	-	-	0~250d settable
Boost charging duration	120min settable	120min settable	120min settable	120min settable	120min settable	10~600min settable

NOTICE

If no BMS is connected, the inverter will charge according to the battery voltage with a preset charging curve. When the inverter communicates with the BMS, it will follow the BMS instructions to perform a more complex stage charging process.

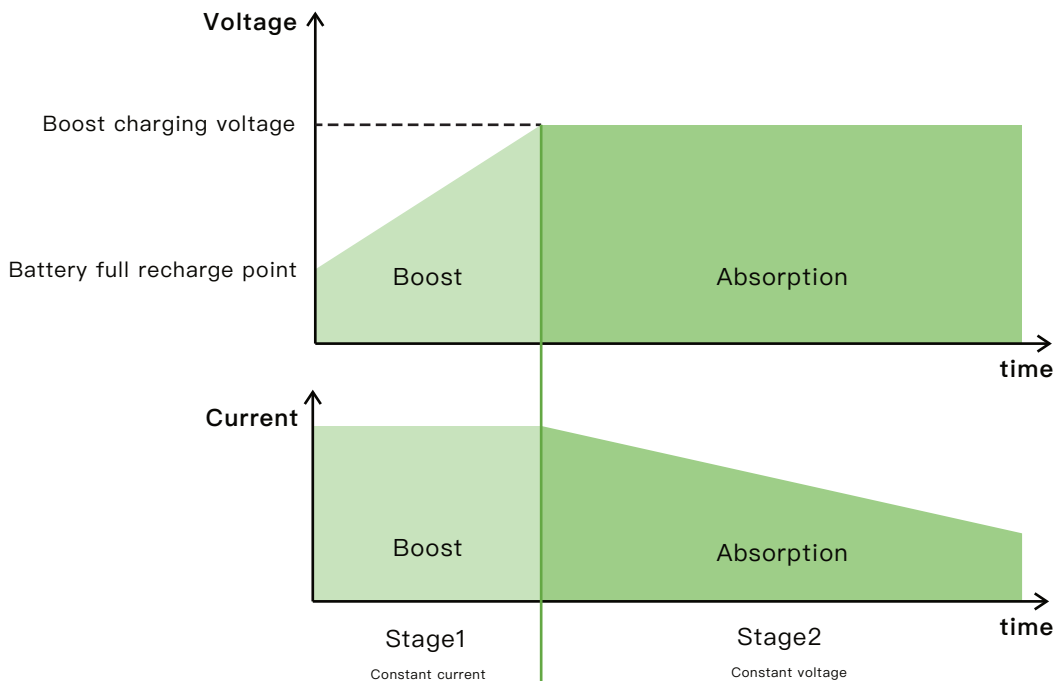

6. Communication

6.1 Overview

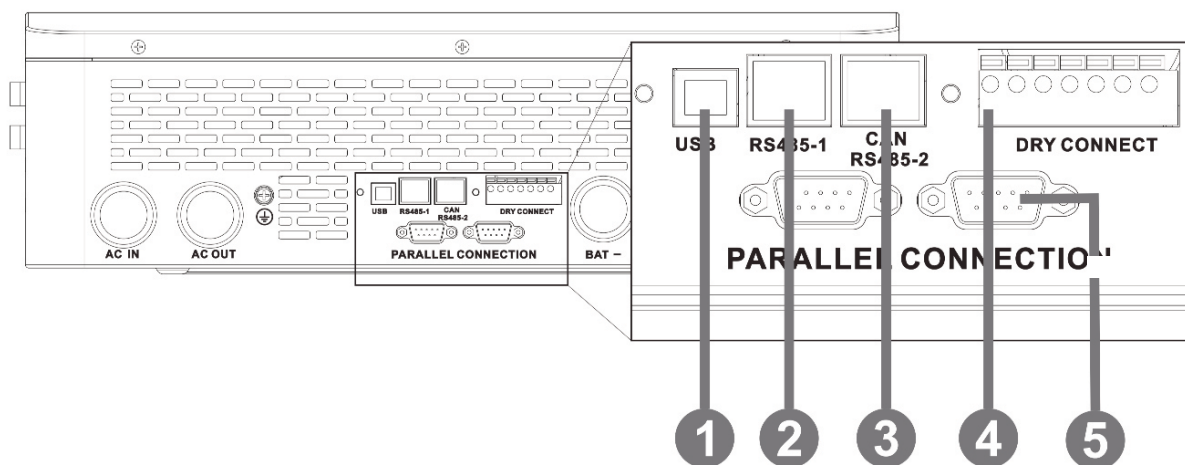

1	USB-B port	2	RS485-1 port	3	RS485-2 port
4	Dry contact port	5	Parallel connection port		

6.2 USB-B port

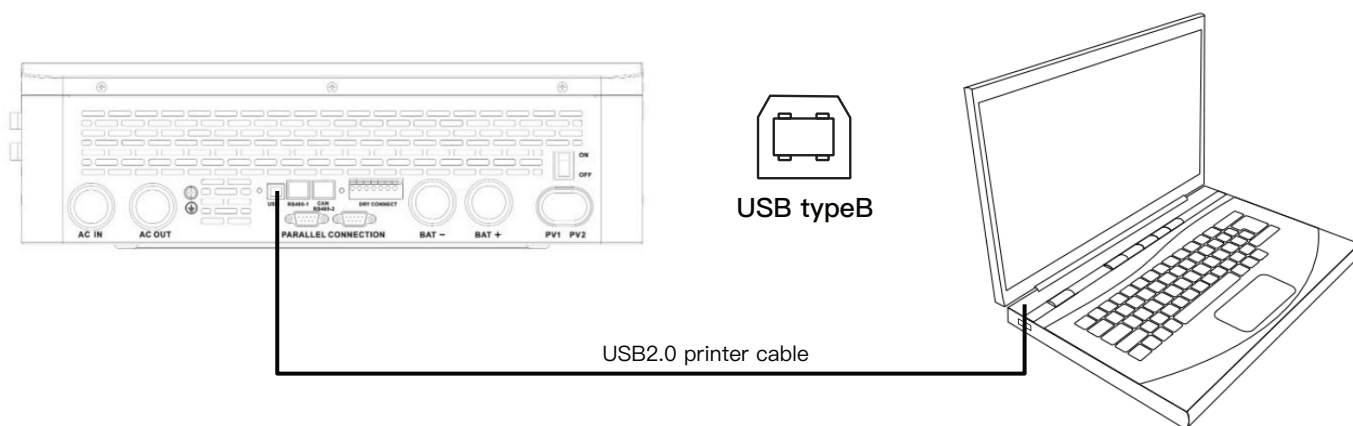

The user can read and modify device parameters through this port by using the host software. Please contact us for the host software installation package if you require one.

6.3 RS485-1 port

The RS485-1 port is used to connect to the Wi-Fi/GPRS data acquisition module, which allows the user to view the operating status and parameters of the inverter via the mobile phone APP.

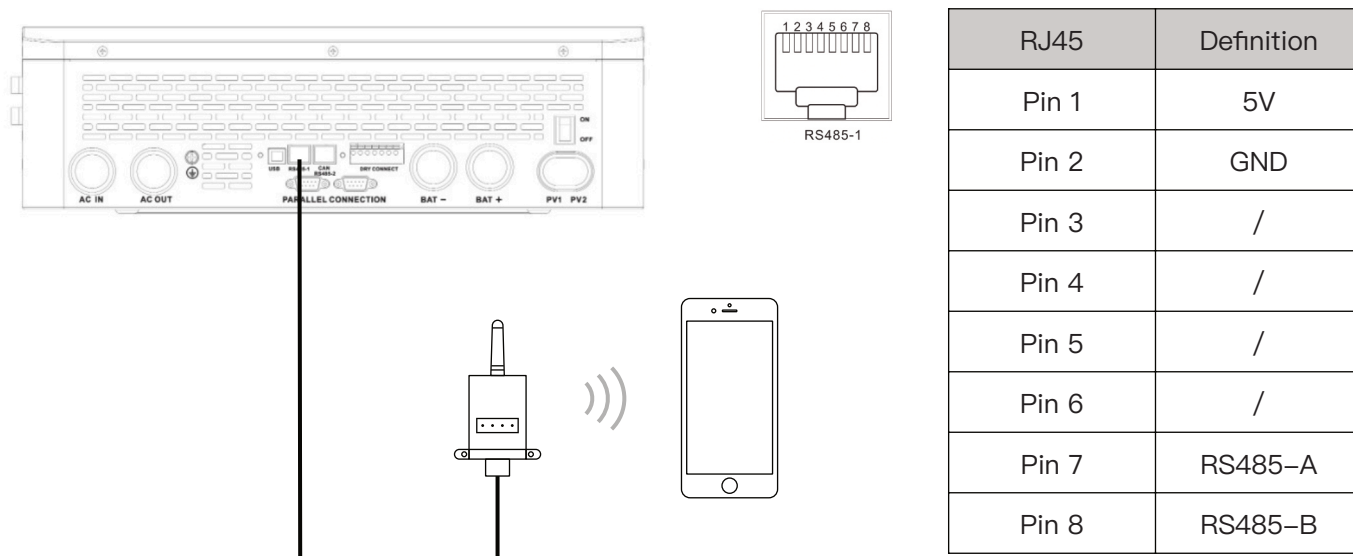

NOTICE

The Wi-Fi/GPRS data acquisition module need to be purchased separately. User can scan the QR code to download the mobile APP.



6.4 CAN/RS485-2 port

The RS485-2 port is used to connect to the BMS of Li-ion battery.

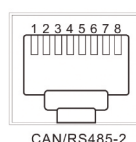

RJ45	Definition
Pin 1	RS485B
Pin 2	RS485A
Pin 3	/
Pin 4	CANH
Pin 5	CANL
Pin 6	/
Pin 7	RS485-A
Pin 8	RS485-B

NOTICE

If you need the inverter to communicate with the lithium battery BMS, please contact us for the communication protocol or to upgrade the inverter to the corresponding software program.

6.5 Dry contact

Dry contact port with 4 functions:

1. Remote switch on/off
2. Switching signal output
3. Battery temperature sampling
4. Generator remote start/stop

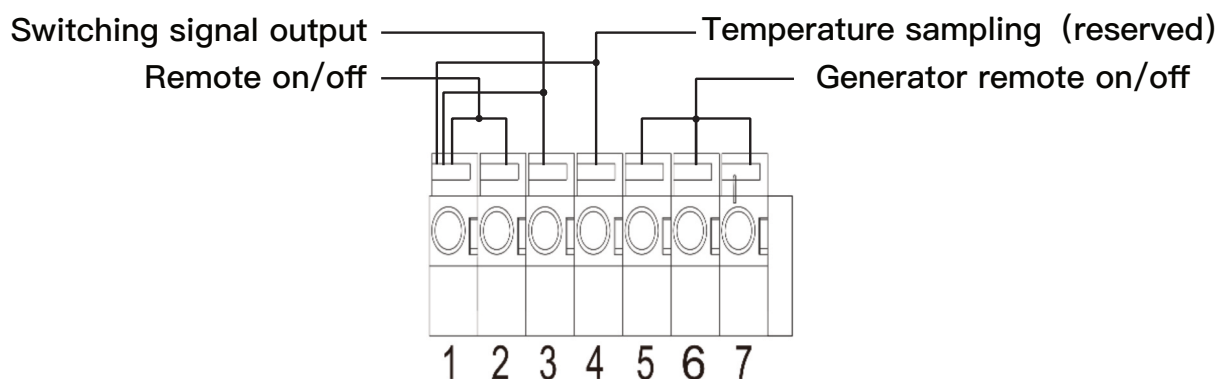

Function	Description
Remote switch on/off	When pin 1 is connected with pin 2, the inverter will be switched off the AC output. When pin 1 is disconnected from pin 2, the inverter outputs normally.
Switching signal output	When the voltage of battery reaches the under-voltage limit voltage (parameter 15), pin 3 to pin 1 voltage is 0V. When the battery is charging/discharging normally, pin 3 to pin 1 voltage is 5V.
Temperature sampling (reserved)	Pin 1 & Pin 4 can be used for battery temperature sampling compensation.
Generator remote start/stop	When the voltage of battery reaches the under-voltage alarm voltage (parameter 14) or voltage point of utility switch to battery (parameter 04), pin 6 to pin 5 is normal open, pin 7 to pin 5 is normal close. When the voltage of battery reaches the voltage point of battery switch to utility (parameter 05) or battery is full, pin 6 to pin 5 is normal close, pin 7 to pin 5 is normal open. (Pin 5/6/7 outputs 125Vac/1A, 230Vac/1A, 30Vdc/1A)

NOTICE

If you need to use the remote start/stop function of the generator with dry contact, ensure that the generator has ATS and supports remote start/stop.

7. Fault and Remedy

7.1 Fault code

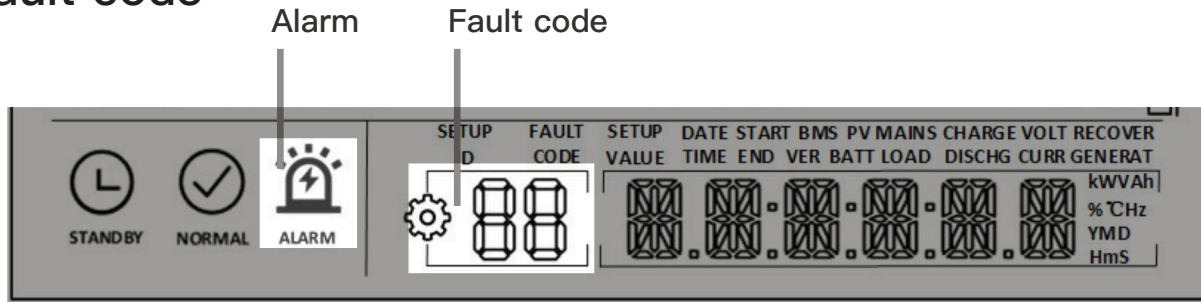

Fault Code	Meaning	Does it Affect the outputs	Instructions
01	BatVoltLow	Yes	Battery under-voltage alarm
02	BatOverCurrSw	Yes	Battery discharge over-current, software protection
03	BatOpen	Yes	Battery disconnected alarm
04	BatLowEod	Yes	Battery under-voltage stop discharging alarm
05	BatOverCurrHw	Yes	Battery over-current hardware protection
06	BatOverVolt	Yes	Battery over-voltage protection
07	BusOverVoltHw	Yes	Busbar over-voltage hardware protection
08	BusOverVoltSw	Yes	Busbar over-voltage software protection
09	PvVoltHigh	Yes	PV input over-voltage protection
10	PvBoostOCSw	No	Boost circuit over-current software protection
11	PvBoostOCHw	No	Boost circuit over-current hardware protection
12	SpiCommErr	Yes	Master-slave chip SPI communication failure
13	OverloadBypass	Yes	Bypass overload protection
14	OverloadInverter	Yes	Inverter overload protection
15	AcOverCurrHw	Yes	Inverter over-current hardware protection
16	AuxDspReqOffPWM	Yes	Slave chip request switch off failure
17	InvShort	Yes	Inverter short-circuit protection
18	Bussoftfailed	Yes	Inverter busbar soft start failed
19	OverTemperMppt	No	MPPT heat sink over-temperature protection
20	OverTemperInv	Yes	Inverter heat sink over-temperature protection
21	FanFail	Yes	Fan failure
22	EEPROM	Yes	Reservoir failure

Fault Code	Meaning	Does it Affect the outputs	Instructions
23	ModelNumErr	Yes	Wrong model
24	Busdiff	Yes	Busbar voltage imbalance
25	BusShort	Yes	Busbar short circuit
26	Rlyshort	Yes	Inverter output back flow to bypass
28	LinePhaseErr	Yes	Utility input phase fault
29	BusVoltLow	Yes	Busbar under-voltage protection
30	BatCapacityLow1	No	Battery SOC below 10% alarm (Only enable BMS take effect)
31	BatCapacityLow2	No	Battery SOC below 5% alarm (Only enable BMS take effect)
32	BatCapacityLowStop	Yes	Battery dead (Only enable BMS take effect)
33	CtrlCanCommErr	Yes	Parallel control can communication fault
34	CanCommFault	Yes	Parallel can communication fault
35	ParaAddrErr	Yes	Parallel ID (communication address) is incorrectly
37	ParaShareCurrErr	Yes	Parallel flow equalisation fault
38	ParaBattVoltDiff	Yes	Parallel mode, large differences in battery voltage
39	ParaAcSrcDiff	Yes	Parallel mode, inconsistent mains input source
40	ParaHwSynErr	Yes	Parallel mode, hardware sync signal failure
41	InvDcVoltErr	Yes	DC component of the inverter voltage is abnormal
42	SysFwVersionDiff	Yes	Inconsistent parallel program versions
43	ParaLineContErr	Yes	Parallel wiring fault
44	Serial number error	Yes	No serial number set at factory
45	Phase merging unit configured incorrectly	Yes	Item [31] is wrongly set
58	BMSComErr	No	BMS communication failure
59	BMSErr	No	BMS failures occur
60	BMSUnderTem	No	BMS under-temperature alarm (Only enable BMS take effect)
61	BMSOverTem	No	BMS over-temperature alarm (Only enable BMS take effect)
62	BMSOverCur	No	BMS over-current alarm (Only enable BMS take effect)
63	BMSUnderVolt	No	BMS under-voltage alarm (Only enable BMS take effect)
64	BMSOverVolt	No	BMS over-voltage alarm (Only enable BMS take effect)

7.2 Troubleshooting

Fault Code	Meaning	Causality	Remedy
/	Screen no display	No power input, or in sleep mode.	Closing the circuit breaker. Ensure the rocker switch is ON. Push any button on the panel to exit sleep mode.
01	Battery under-voltage	The battery voltage is lower than the value set in parameter [14].	Charge the battery and wait until the battery voltage is higher than the value set in the parameter item [14].
03	Battery not connected	The battery is not connected, or the BMS in discharge protection	Check whether the battery is reliably connected; check whether the circuit breaker of the battery is not closed; ensure that the BMS of the Li-ion battery can communicate properly.
04	Battery over-discharge	The battery voltage is lower than the value set in the parameter [12].	Manual reset: Power off and restart. Automatic reset: charge the battery so that the battery voltage is higher than the value set in the parameter item [35].
06	Battery over-voltage when charging	Battery is in over-voltage condition.	Manually power off and restart. Check to see if the battery voltage exceeds the limit. If it exceeds, the battery needs to be discharged until the voltage is below the battery's over-voltage recovery point.
13	Bypass over-load (software detection)	Bypass output power or output current overload for a certain period of time.	Reduce the load power and restart the device. Please refer to item 11 of the protection features for more details.
14	Inverter over-load (software detection)	Inverter output power or output current overload for a certain period of time.	
19	Heat sink of PV input over-temperature (software detection)	Heat sink of PV input temperature exceeds 90°C for 3s.	Resume normal charge and discharge when the temperature of the heat sink has cooled to below the over-temperature recovery temperature.
20	Heat sink of inversion over-temperature (software detection)	Heat sink of inversion temperature exceeds 90°C for 3s.	
21	Fan failure	Fan failure detects by hardware for 3s.	Manually toggle the fan after switching off to check for blockage by foreign objects.
26	AC Input relay short-circuit	Relay for AC input sticking	Manually power off and restart; if the fault reappears after restarting, You need to contact the after-sales service to repair the machine.
28	Utility input phase fault	AC input phase does not coincide with AC output phase	Ensure that the phase of the AC input is the same as the phase of the AC output, e.g. if the output is in split-phase mode, the input must also be in split-phase.

NOTICE

If you encounter a fault with the product that cannot be solved by the methods in the table above, please contact our after-sales service for technical support and do not disassemble the equipment yourself.

8. Protection and Maintenance

8.1 Protection features

No	Protection Feature	Instruction
1	PV input current/power limiting protection	When the charging current or power of the PV array configured exceeds the PV input rated value, the inverter will limit the input power and charge at the rated.
2	PV input over-voltage	If the PV voltage exceeds the maximum value allowed by the hardware, the machine will report a fault and stop the PV boost to output a sinusoidal AC wave.
3	PV night reverse current protection	At night, the battery is prevented from discharging through the PV module because the battery voltage is greater than the voltage of PV module.
4	AC input over-voltage protection	When the AC input voltage of each phase exceeds 280V, the mains charging will be stopped and switched to the inverter mode.
5	AC input under-voltage protection	When the AC input voltage of each phase below 170V, the utility charging will be stopped and switched to the inverter mode.
6	Battery over-voltage protection	When the battery voltage reaches the over-voltage cut-off point, the PV and the utility will automatically stop charging to prevent the battery from being overcharged and damaged.
7	Battery under-voltage protection	When the battery voltage reaches the under-voltage cut-off point, the inverter will automatically stop the battery discharge to prevent damage from over-discharging the battery.
8	Battery over-current protection	After a period when the battery current exceeds that allowed by the hardware, the machine will switch off the output and stop discharging the battery.
9	AC output short-circuit protection	When a short-circuit fault occurs at the load output terminal, the AC output is immediately turned off and turned on after 1 second. If the output load terminal is still short-circuited after 3 attempts, the inverter must be manually restarted after first removing the short-circuit fault from the load before the normal output can be restored.
10	Heat sink over-temperature protection	When the internal temperature of the inverter is too high, the inverter will stop charging and discharging; when the temperature returns to normal, the inverter will resume charging and discharging.
11	Inverter over-load protection	After triggering the overload protection the inverter will resume output after 3 minutes, 5 consecutive overloads will switch off the output until the inverter is restarted.

No	Protection Feature	Instruction
11	Inverter over-load protection	(102%<load<110%) ±10%: error and output shutdown after 5min; (110% < load < 125%) ±10%: error and output shutdown after 10s. Load > 125% ±10%: error reported and output switched off after 5s.
12	AC output reverse	Prevents AC back flow from the battery inverter to the bypass AC input.
13	Bypass over-current protection	Built-in AC input over-current protection circuit breaker.
14	Bypass phase inconsistency protection	When the phase of the bypass input and the phase of the inverter split do not match, the inverter disables switching to the bypass output to prevent the load from dropping out or short-circuiting when switching to the bypass.

8.2 Maintenance

To maintain optimum and long-lasting working performance, we recommend that the following items are checked twice a year.

1. Ensure that the airflow around the inverter is not blocked and remove any dirt or debris from the radiator.
2. Check that all exposed conductors are not damaged by sunlight, friction with other surrounding objects, dry rot, insect or rodent damage, etc. The conductors need to be repaired or replaced if necessary.
3. Verify that the indications and displays are consistent with the operation of the equipment, note any faults or incorrect displays and take corrective action if necessary.
4. Check all terminals for signs of corrosion, insulation damage, high temperatures or burning/discolouration and tighten terminal screws.
5. Check for dirt, nesting insects and corrosion, clean anti insects net as required.
6. If the lightning arrester has failed, replace the failed arrester in time to prevent lightning damage to the inverter or other equipment of the user.

DANGER

- Make sure that the inverter is disconnected from all power sources and that the capacitors are fully discharged before carrying out any checks or operations to avoid the risk of electric shock.

The Company shall not be liable for damage caused by :

1. Damage caused by improper use or use in a wrong location.
2. Photovoltaic modules with an open circuit voltage exceeding the maximum permissible voltage.
3. Damage caused by the operating temperature exceeding the restricted operating temperature range.
4. Dismantling and repair of the inverter by unauthorised persons.
5. Damage caused by force majeure: damage during transport or handling of the inverter.

9. Datasheet

MODEL	SPI-8K-SP	SPI-10K-SP	CAN BE SET
INVERTER OUTPUT			
Rated Output Power	8,000W	10,000W	
Max.Peak Power	12,000W	15,000W	
Rated Output Voltage	230Vac(Single phase)		Y
Load Capacity of Motors	5HP	6HP	
Rated AC Frequency	50/60Hz		Y
Waveform	Pure Sine Wave		
Switch Time	10ms (typical)		
Parallel capacity	1 ~ 6 units		
Overload	<p>After triggering the overload protection the inverter will resume output after 3 minutes, 5 consecutive overloads will switch off the output until the inverter is restarted.</p> <p>(102%<load<110%) ±10%: error and output shutdown after 5mins;</p> <p>(110% < load < 125%) ±10%: error and output shutdown after 10s.</p> <p>Load > 125% ±10%: error reported and output switched off after 5s.</p>		
BATTERY			
Battery Type	Li-ion / Lead-Acid / User Defined		Y
Rated Battery Voltage	48Vdc		
Voltage Range	40-60Vdc		Y
Max.MPPT Charging Current	180A	200A	Y
Max.Mains/Generator Charging Current	100A	120A	Y
Max.Hybrid Charging Current	180A	200A	Y
PV INPUT			
Num. of MPP Trackers	2		
Max.PV array power	5500W+5500W		
Max.input current	22A+22A		
Max.Voltage of Open Circuit	500Vdc+500Vdc		
MPPT Voltage Range	125-425Vdc		
MAINS / GENERATOR INPUT			
Input Voltage Range	90-275Vac		
Frequency Range	50/60Hz		
Bypass Overload Current	63A		
EFFICIENCY			
MPPT Tracking Efficiency	99.9%		
Max. Battery Inverter Efficiency	92%		

MODEL	SPI-8K-SP	SPI-10K-SP	CAN BE SET
GENERAL			
Dimensions	620*445*130mm (2.03*1.46*0.43ft)		
Weight	27kg (59.52lb)		
Protection Degree	IP20, Indoor Only		
Operating Temperature Range	-10~55°C, >45°C derated (14~131°F, >113°F derated)		
Noise	<60dB		
Cooling Method	Internal Fan		
Warranty	2 Years		
COMMUNICATION			
Embedded Interfaces	RS485 / CAN / USB / Dry contact		Y
External Modules (Optional)	Wi-Fi / GPRS		Y
CERTIFICATION			
Safety	IEC62109-1, IEC62109-2		
EMC	EN61000-6-1, EN61000-6-3, FCC 15 class B		
RoHS	Yes		